

AesthEdge

www.aesthedge.com



AesthEdge



+8618953955575



angela@aesthedge.com



www.aesthedge.com



Rm1103, A10Building, Lushang Center, Guangzhou Road,
Lanshan District, Linyi City, Shandong Province, China

**HOT SELLING PRODUCTS
CATALOGUE**



AesthEdge

Contents

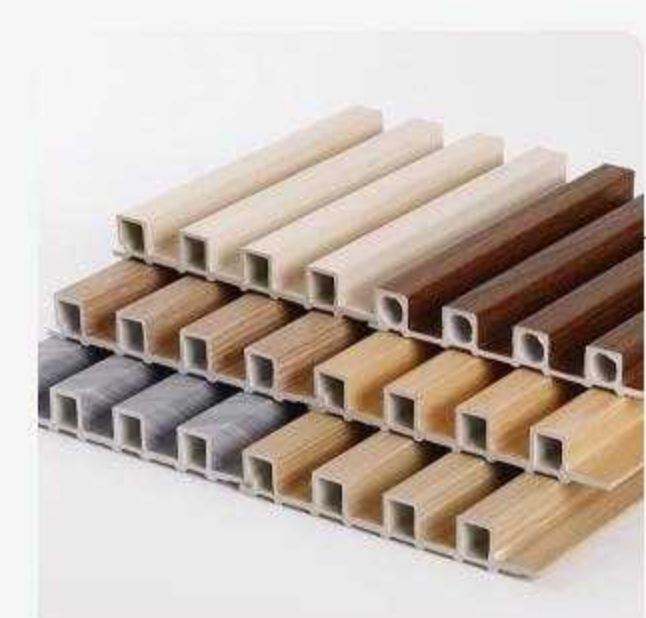

01

WPC Wall Panel

03-9



02

WPC Ceiling

10-12



03

WPC Timber Tube

13-15



04

WPC Foam Board

16-23



05

PVC Marble Sheet

24-31



07

Slat Acoustic Panel

36-39



09

Outdoor Wall Panel

48-51



06

PS Wall Panel

32-35



08

PU Stone Panel

40-47



10

Outdoor Decking

52-56

AesthEdge Presentation

AesthEdge specializes in designing, manufacturing, and distributing innovative, eco-friendly decor coverings and wall protection solutions. Our main products include WPC Panels, PVC Marble Sheets, WPC Foam Boards, PS Wall Panels, Slat Acoustic Panels, PU Stone Panels, Outdoor Wall Panels, and related accessories.



SINCE 2005

19 years exported to more than 60+countries



50,000

Covering a land-area of about 50,000 square meters



35+

A 35 person sales team and quick response



Home



Facility



Hotel

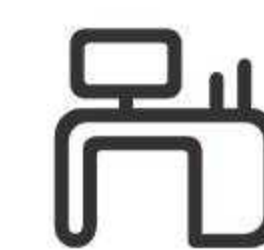

Office



Sport Area



Factory



Public Housing



School



Retail Store



Transport

CREATING COMFORTABLE

NATURAL AESTHETICS

Since the establishment, AesthEdge has adhered to the principles of prioritizing customers, maintaining a strong reputation, focusing on quality, and delivering exceptional service. We continually develop new materials, innovate designs, and enhance our quality management system. This enables us to provide comprehensive solutions and offer OEM and ODM services to our customers.

WE CARE /WE ACT

Our Commitments for a Sustainable future



Using sustainable materials



Carbonfootprint
-20 % kg



Recyclable

www.aesthedge.com

01 WPC Wall Panel

Hot-selling product series

The WPC Wall Panel is mainly a kind of wall decoration board made of wood-plastic material. Because the cross section is like the WPCWall Panel, it is called the WPC Wall Panel.

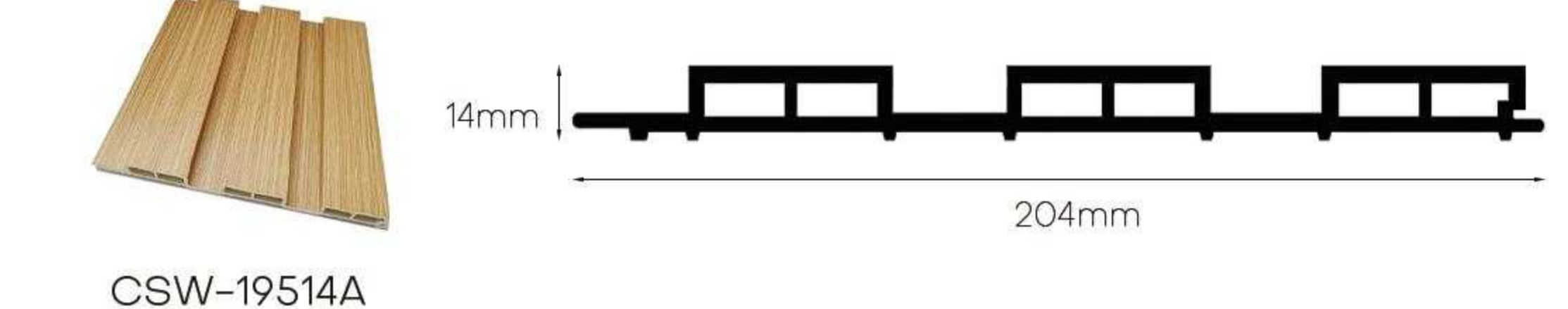
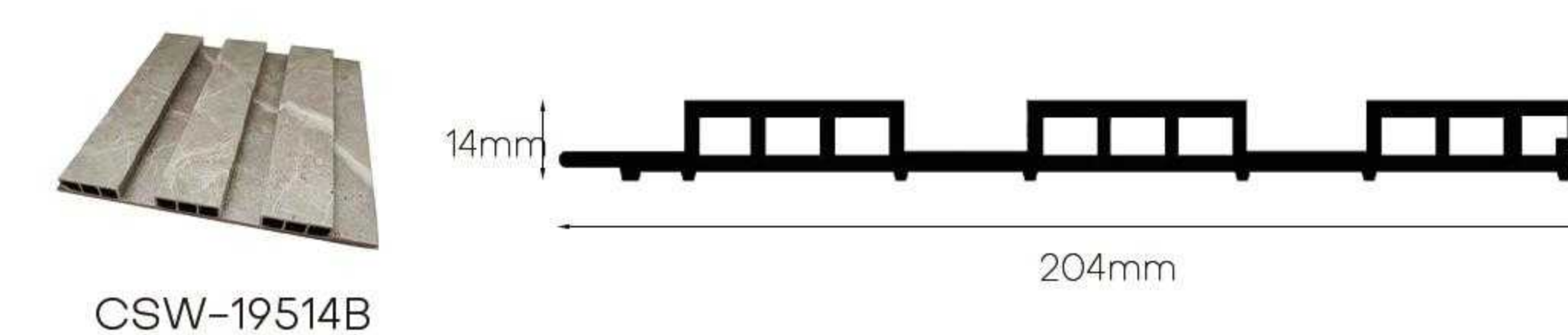
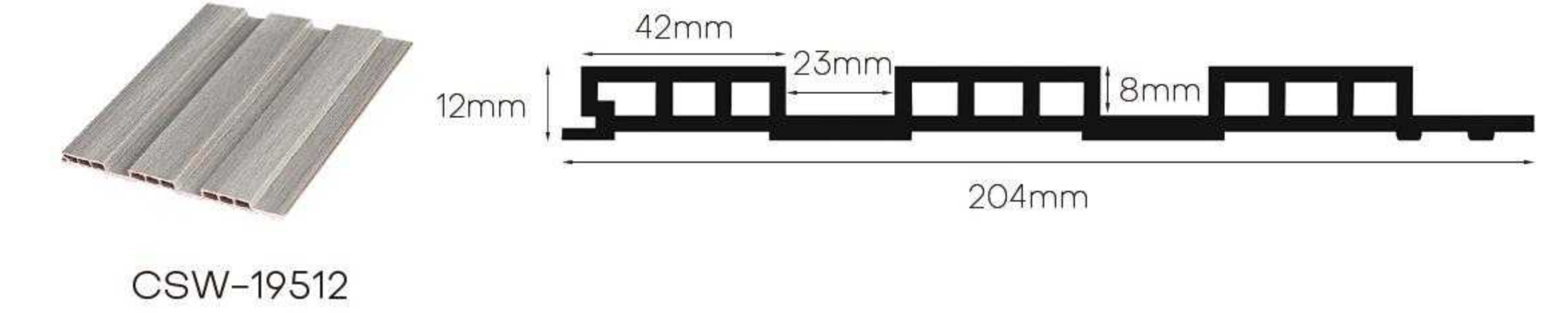
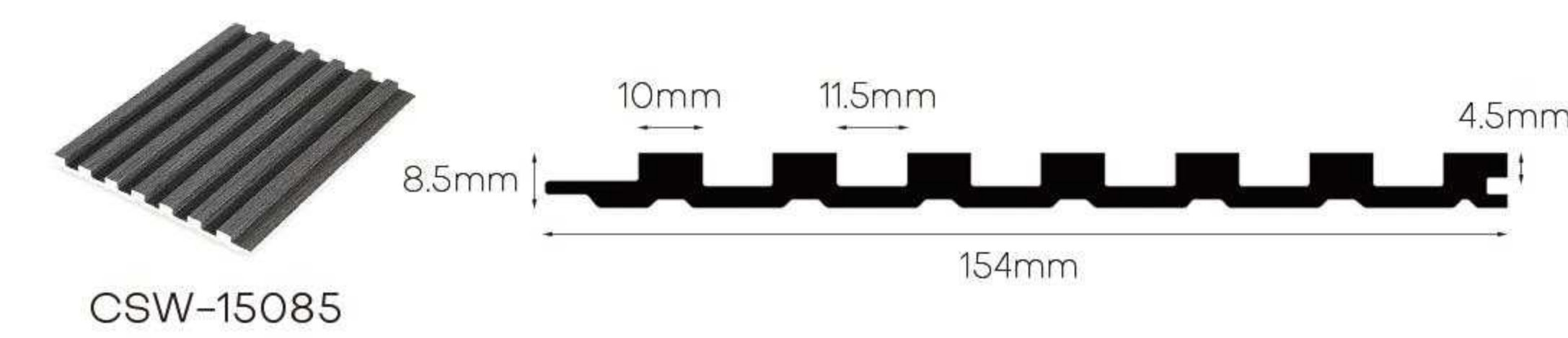
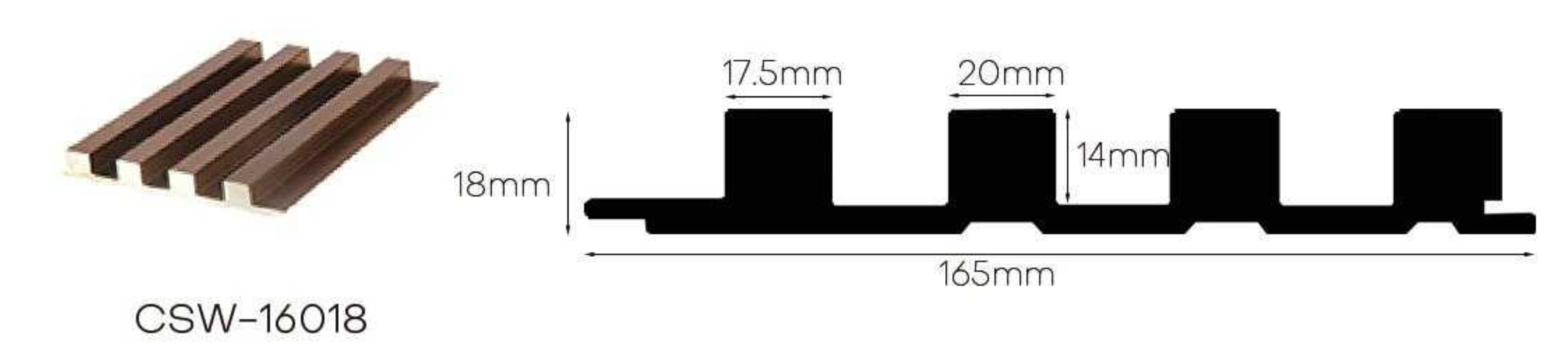
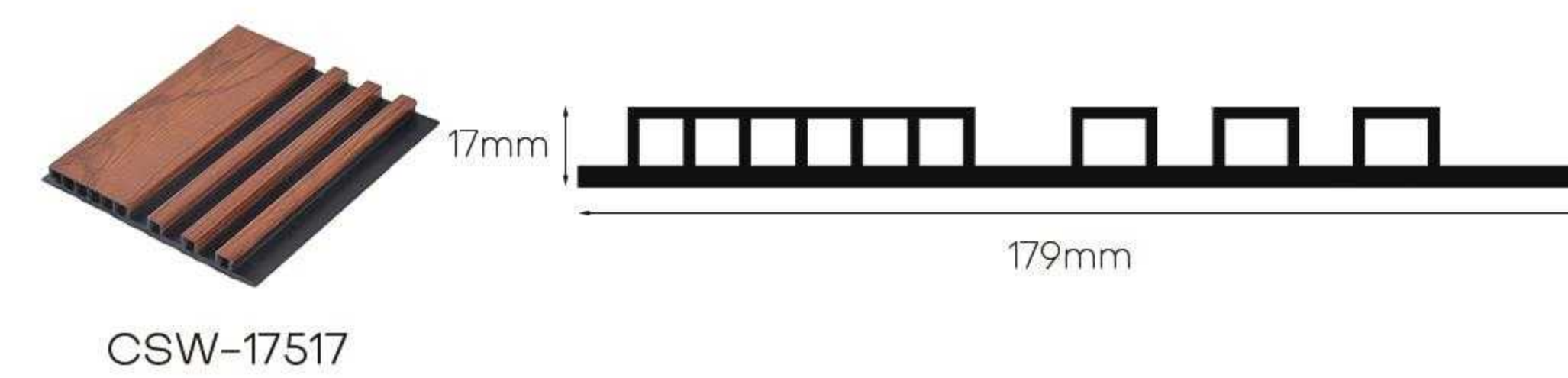
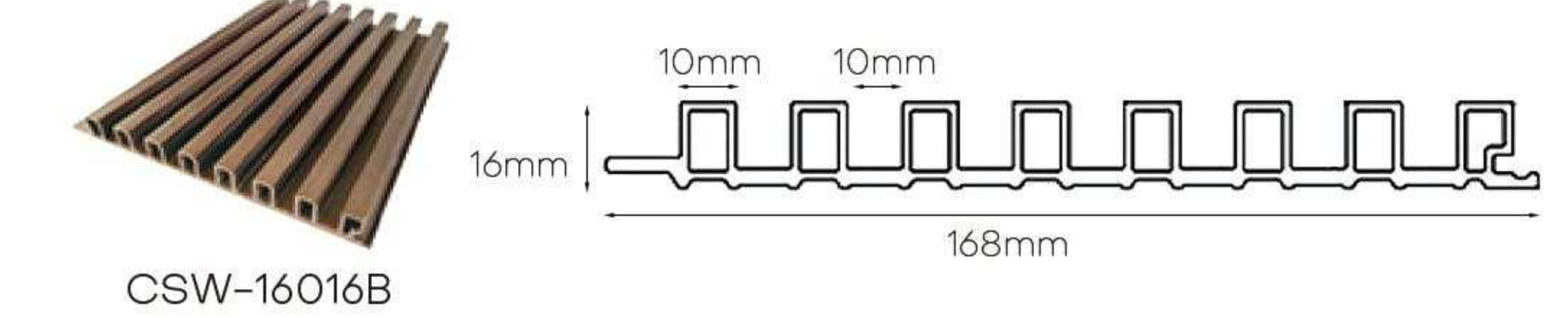
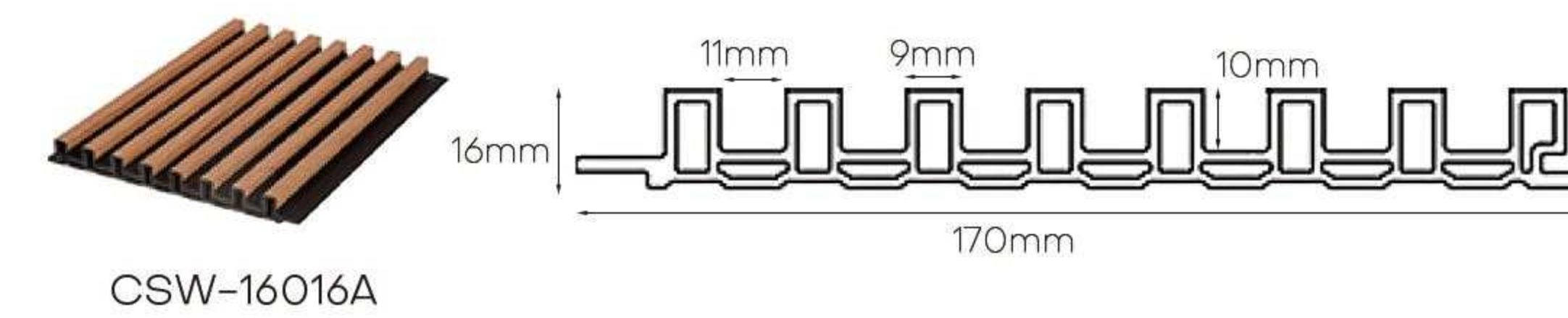
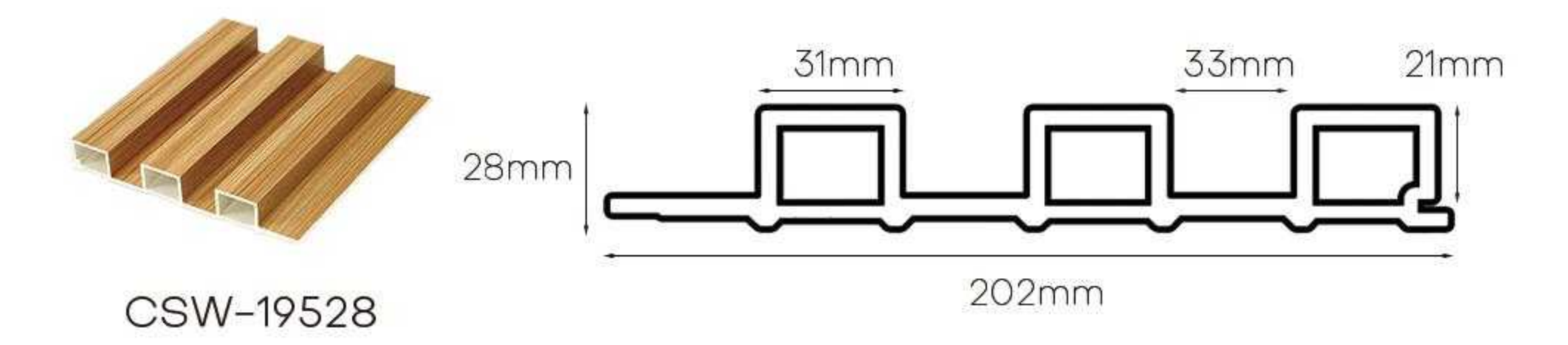
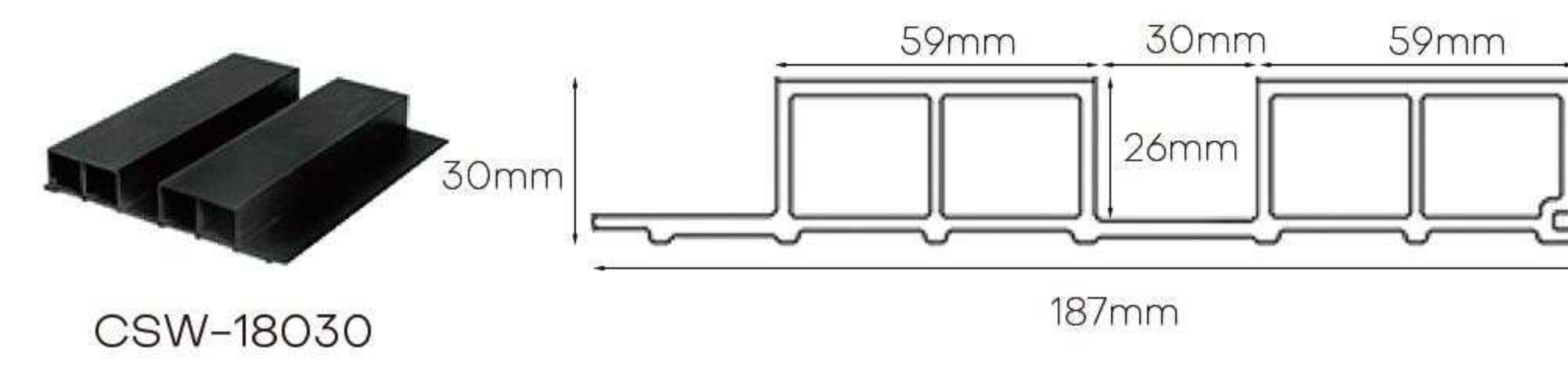
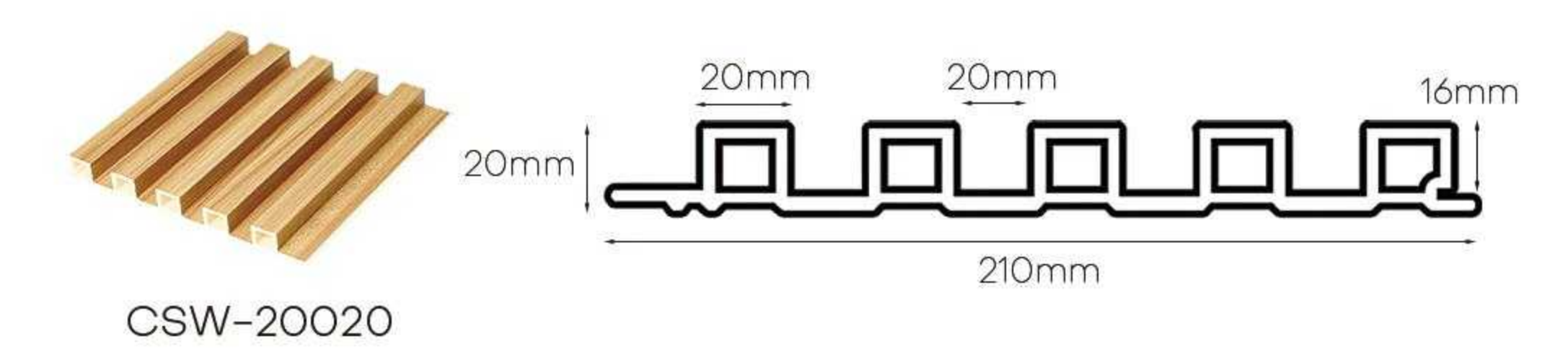
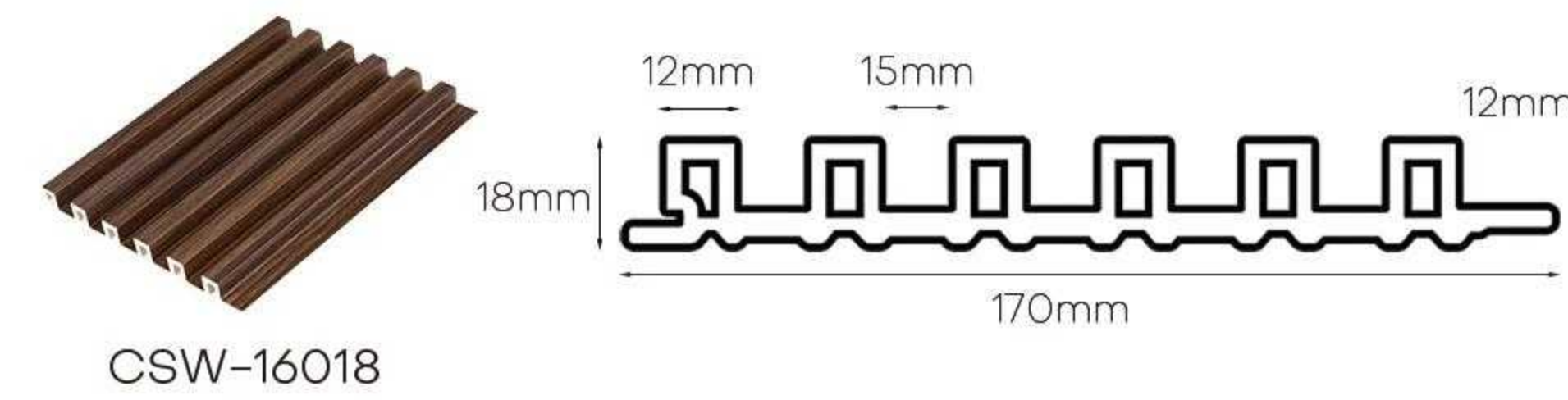
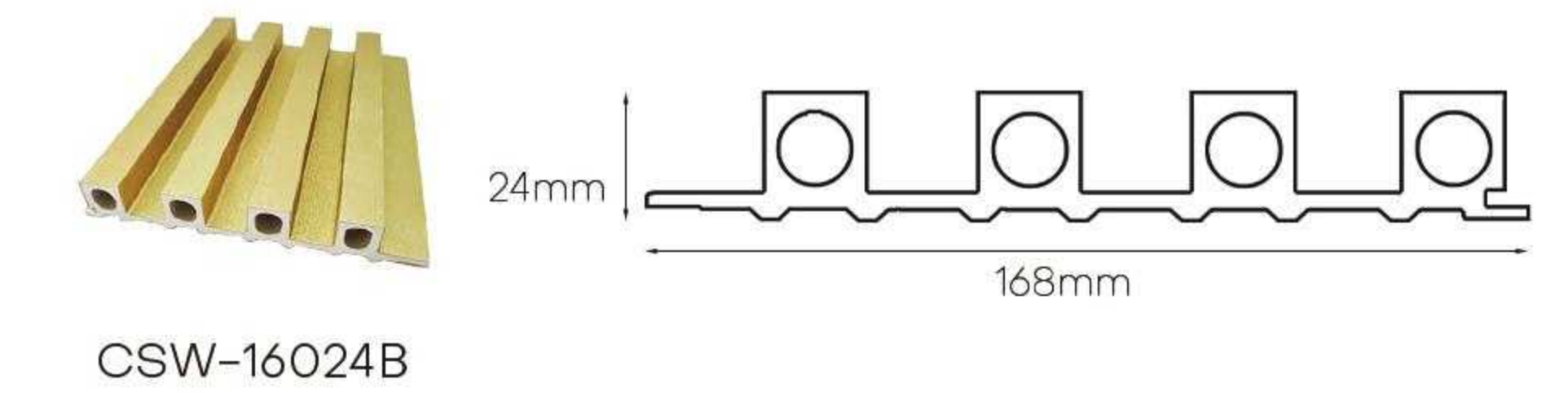
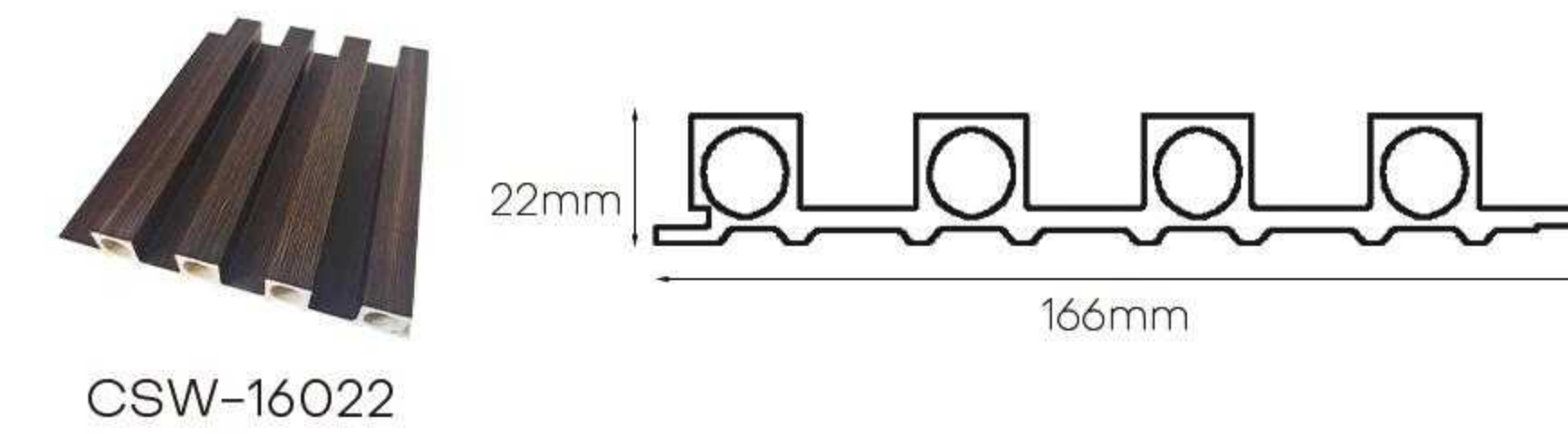
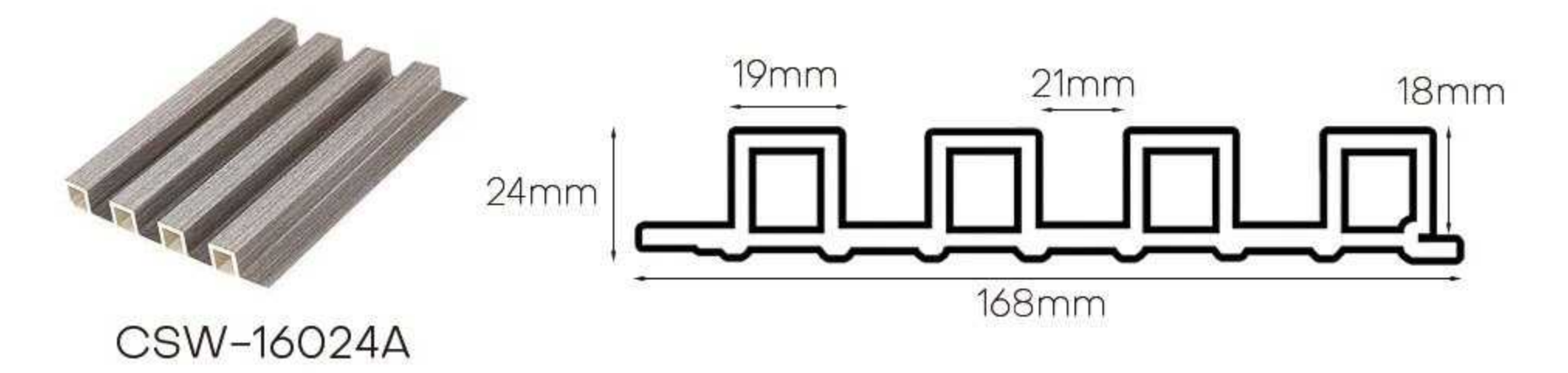
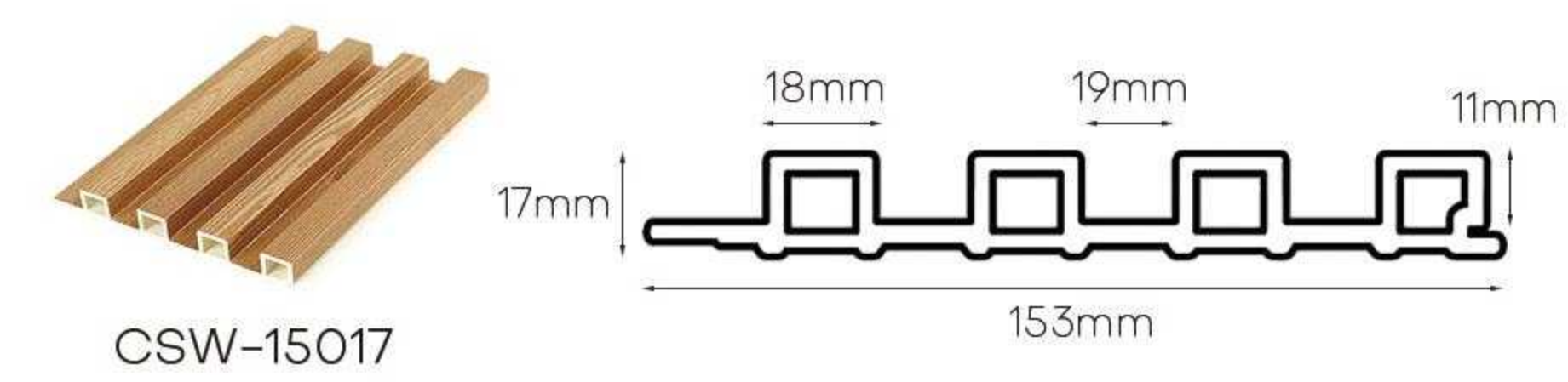
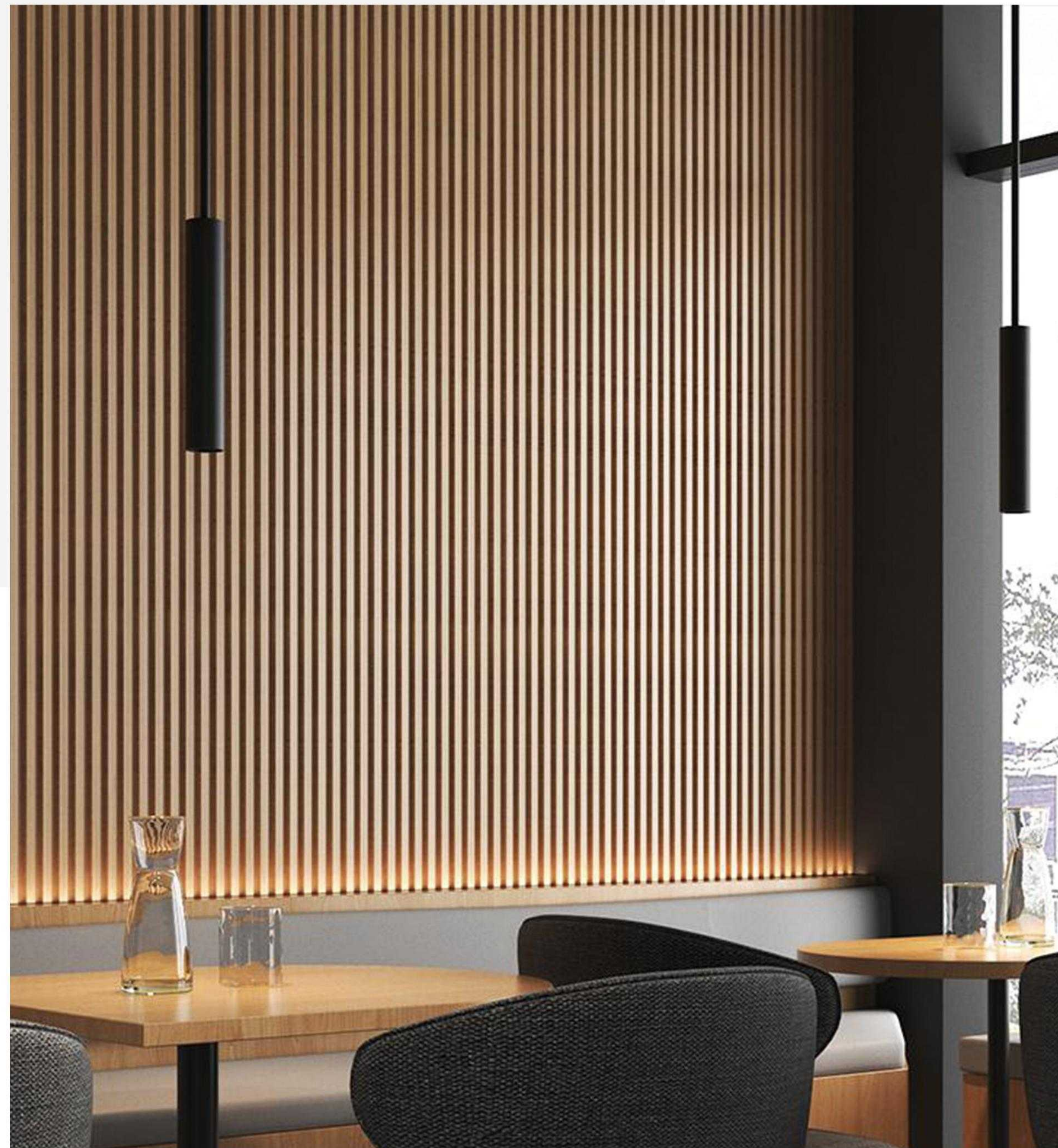

01 WPC Wall Panel
Hot-selling product series

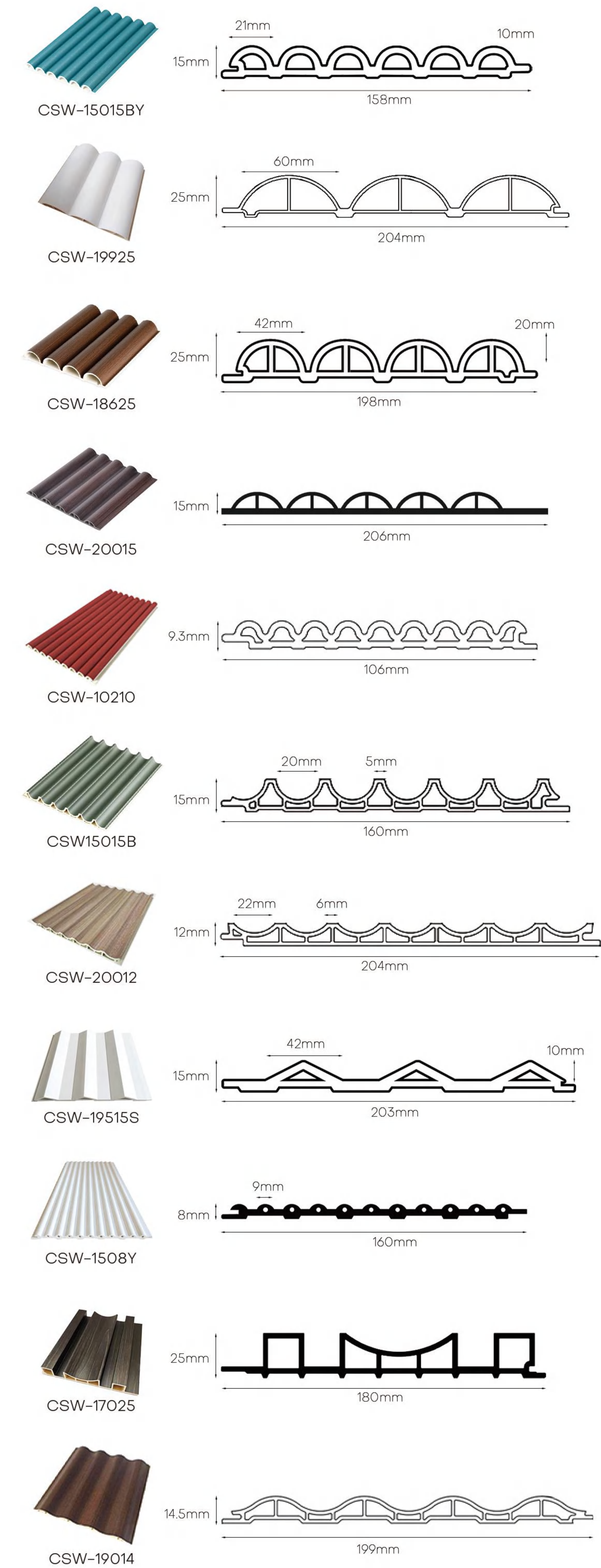

01 WPC Wall Panel

Hot-selling product series

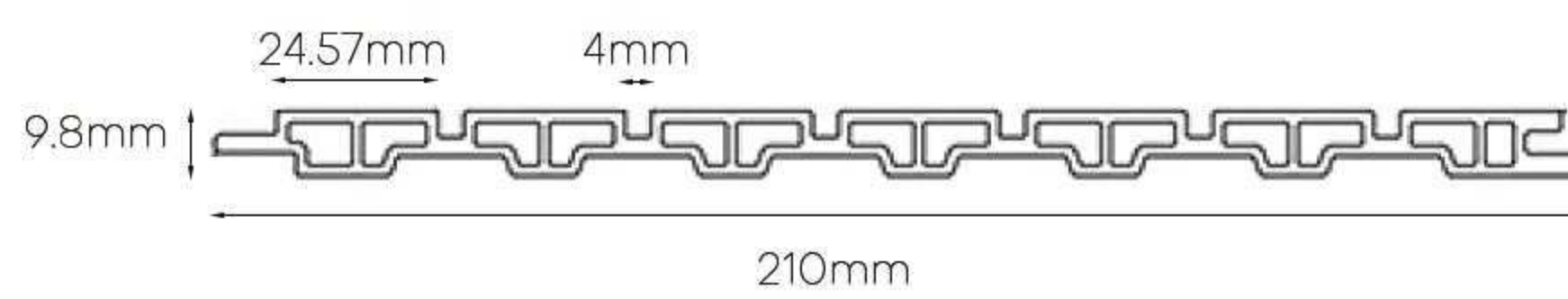
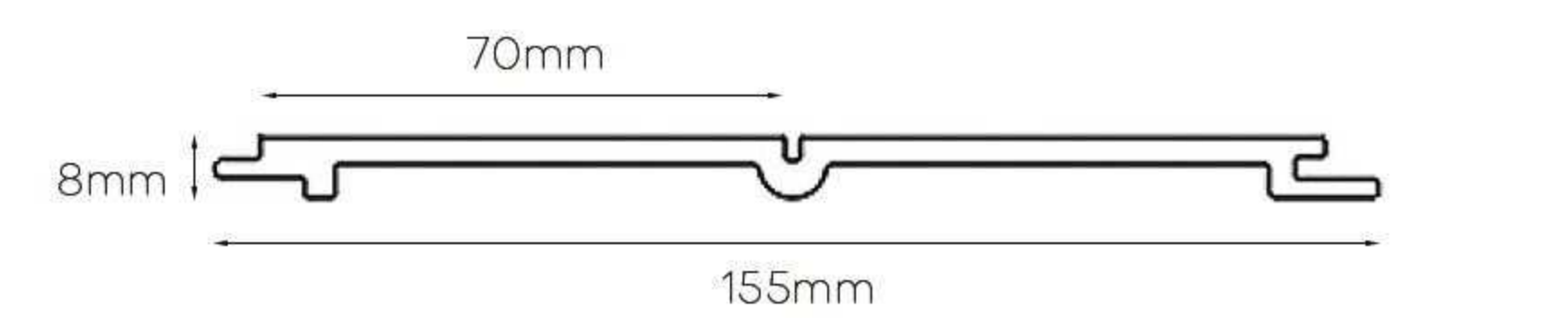
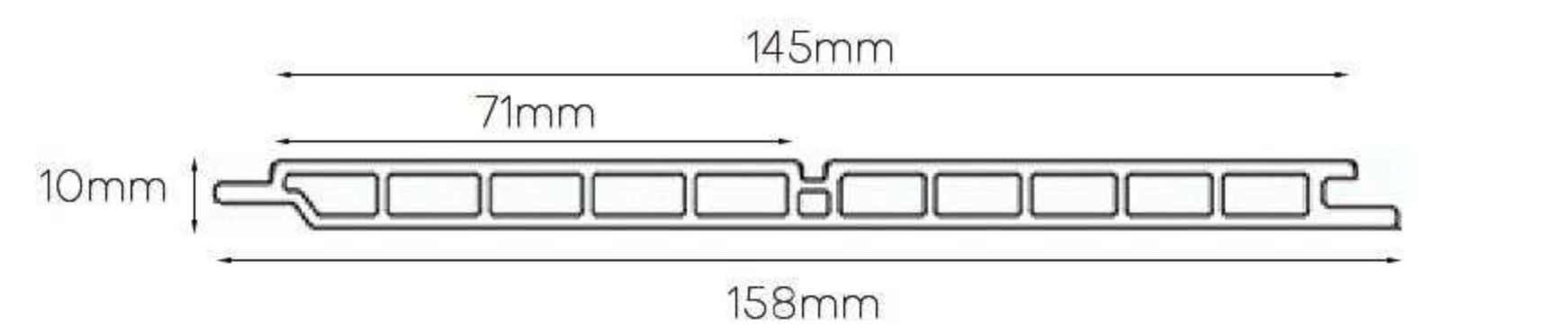
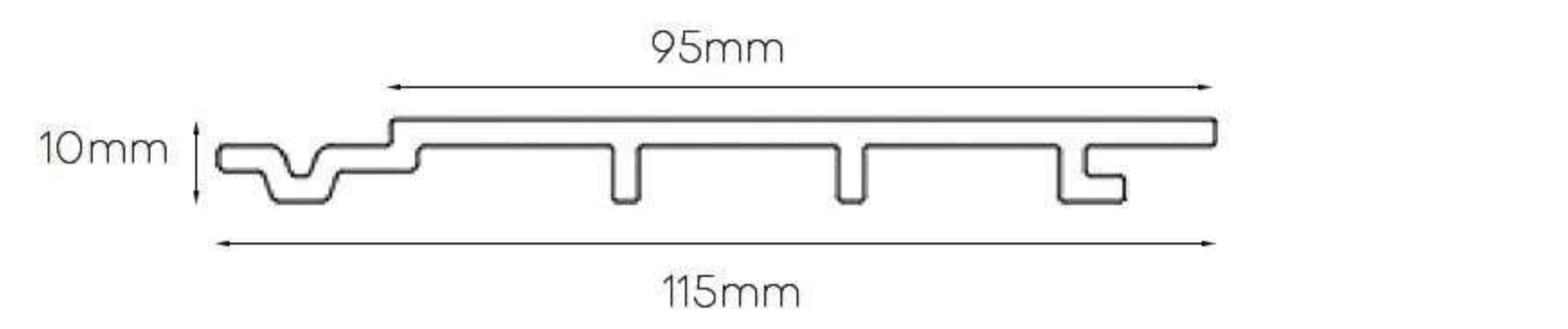
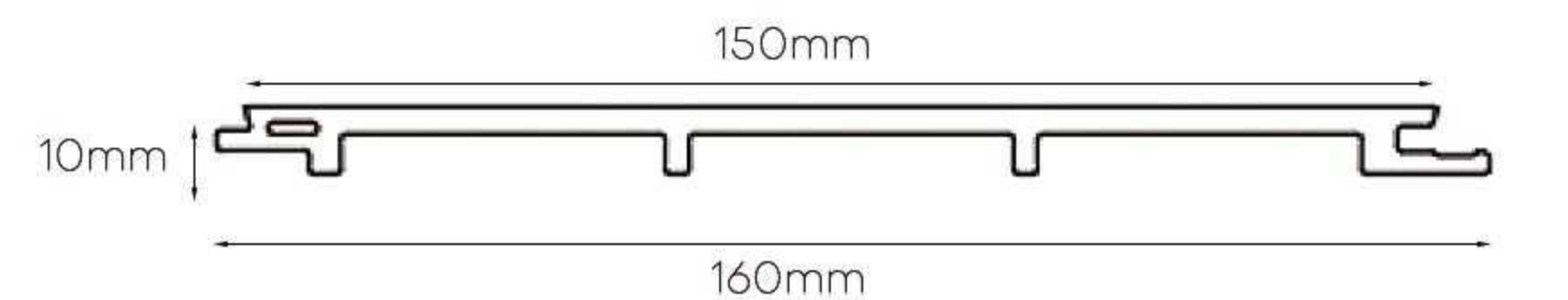
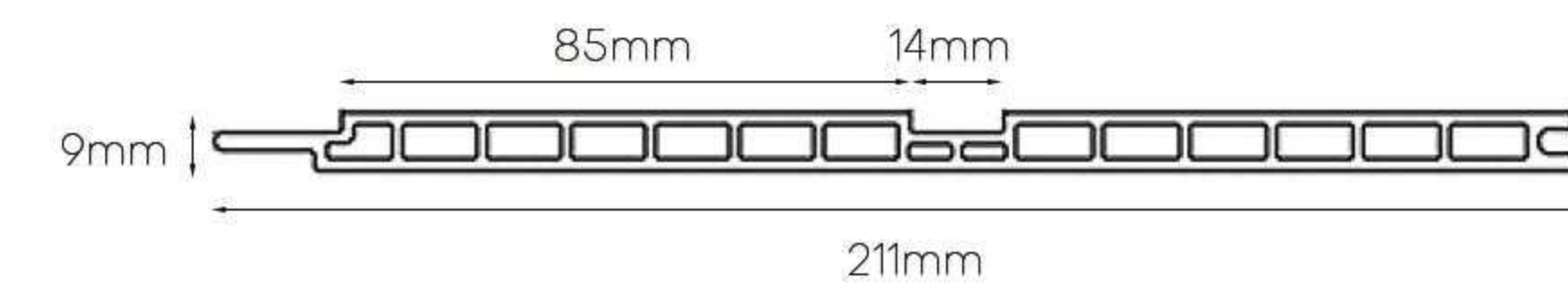
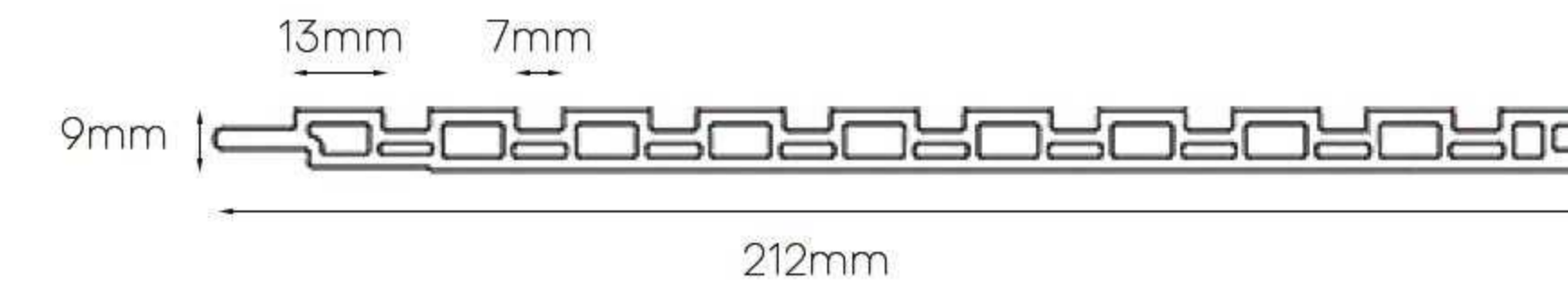
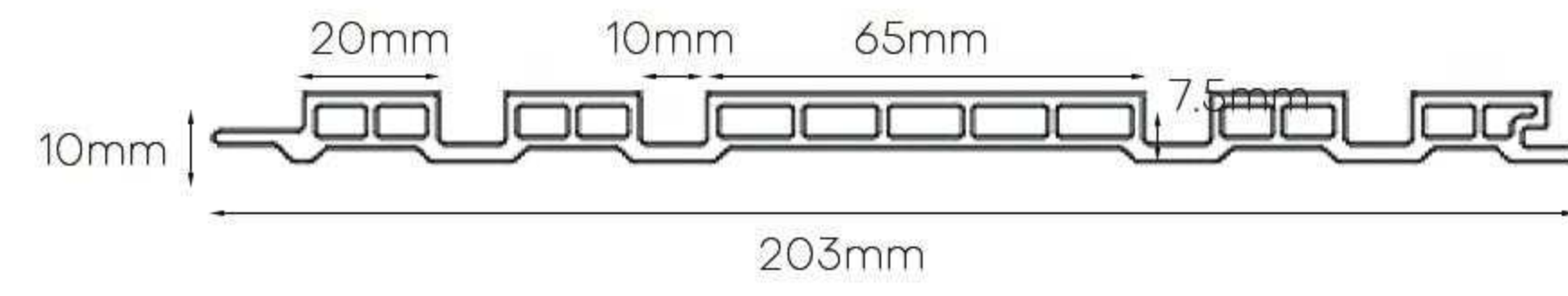
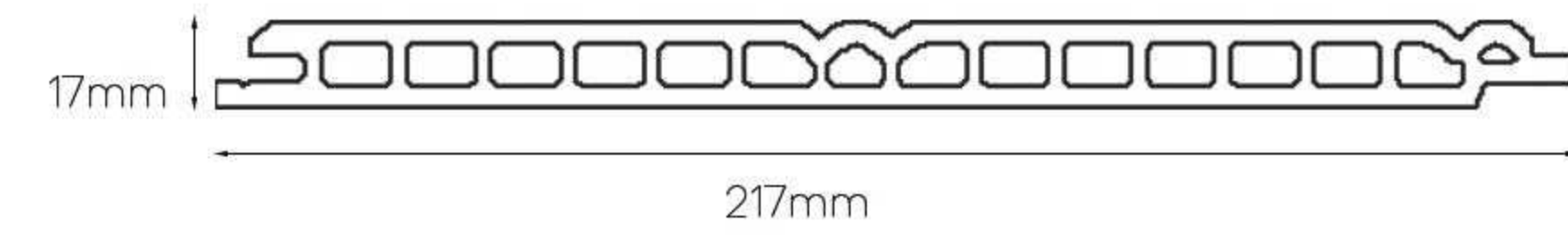

01 WPC Wall Panel

Accessories

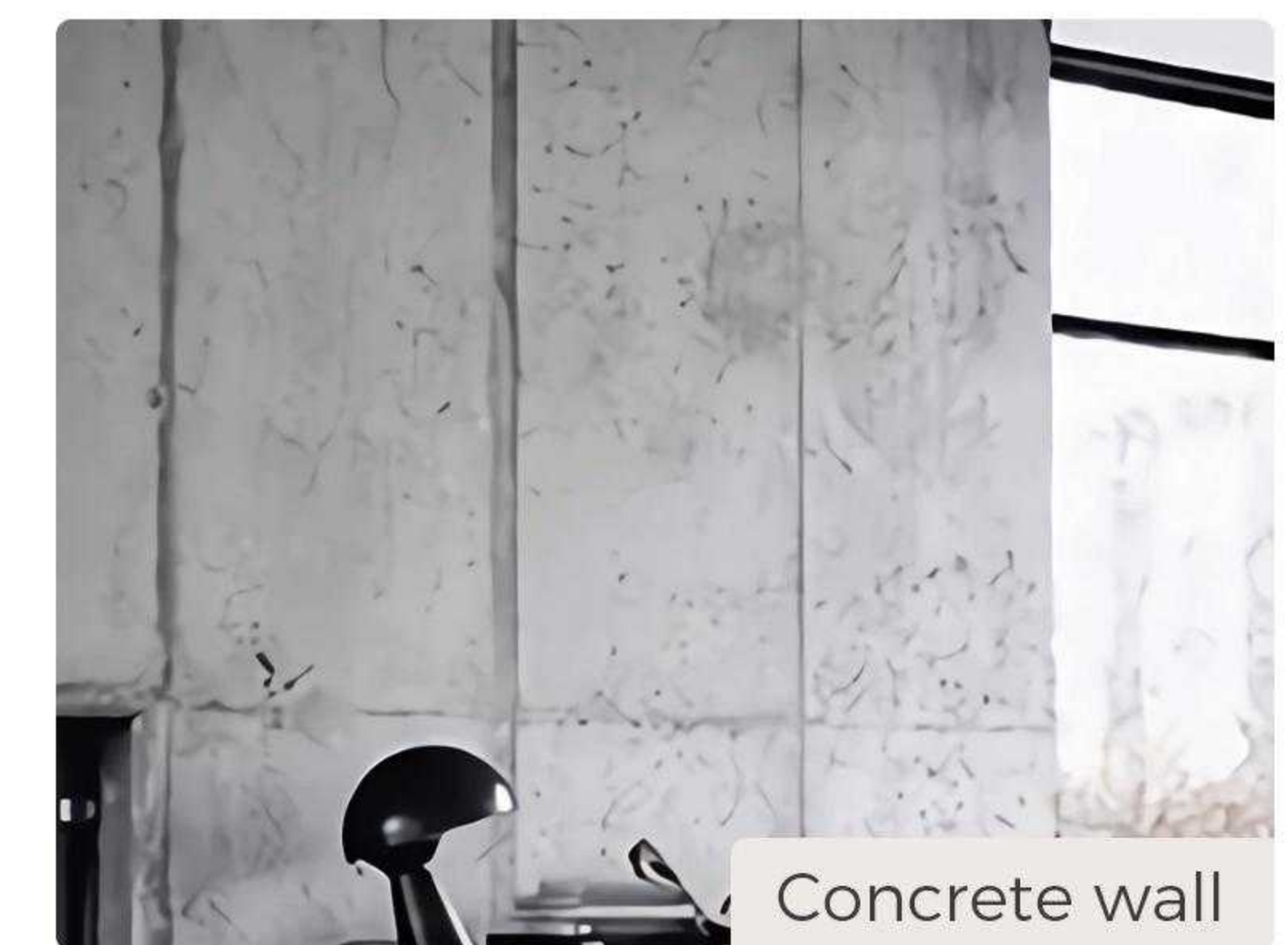

01 WPC Wall Panel

Installation Method

• Methods 1



It is better to drive the nail diagonally into the hard surface.
The nail gun can be covered with another board that plugs in
It doesn't affect the aesthetics.

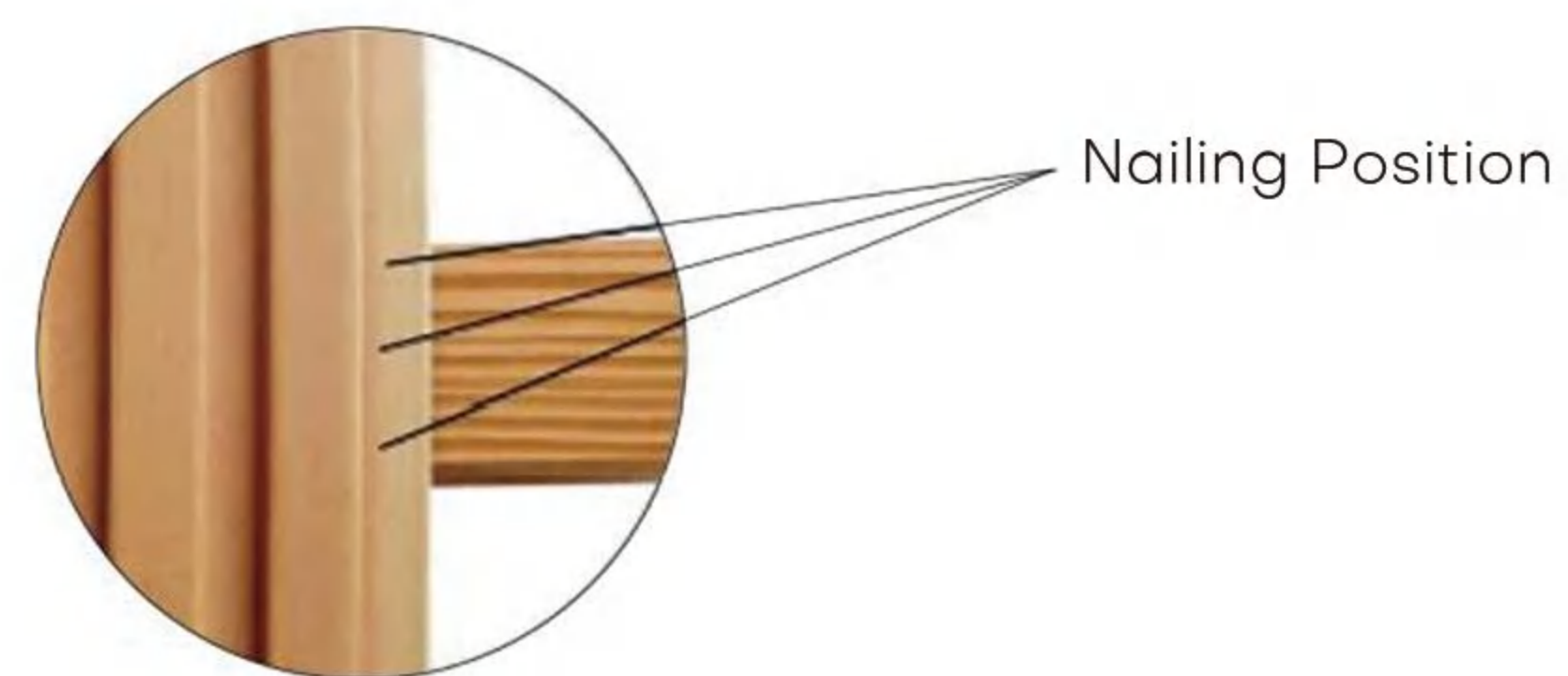

• Methods 2

Insert the fastener into the bottom edge of the wall panel
Fixed to the blank wall
This method applies to the wall with smooth surface wall with a flat surface

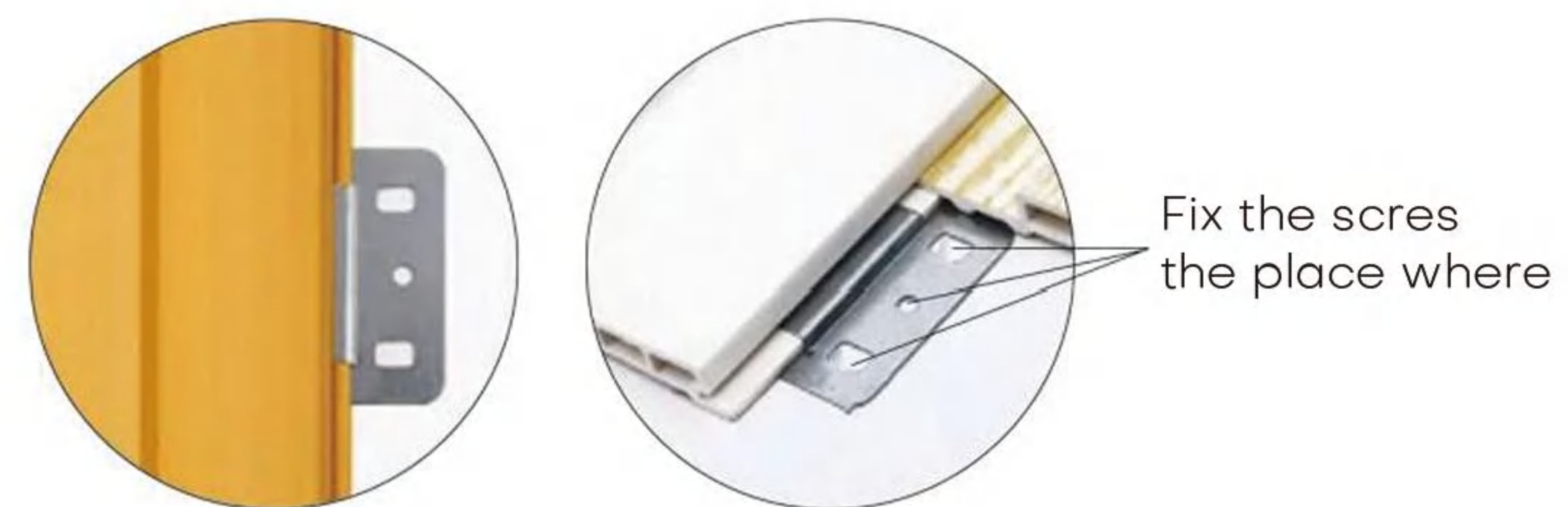

• Methods 3

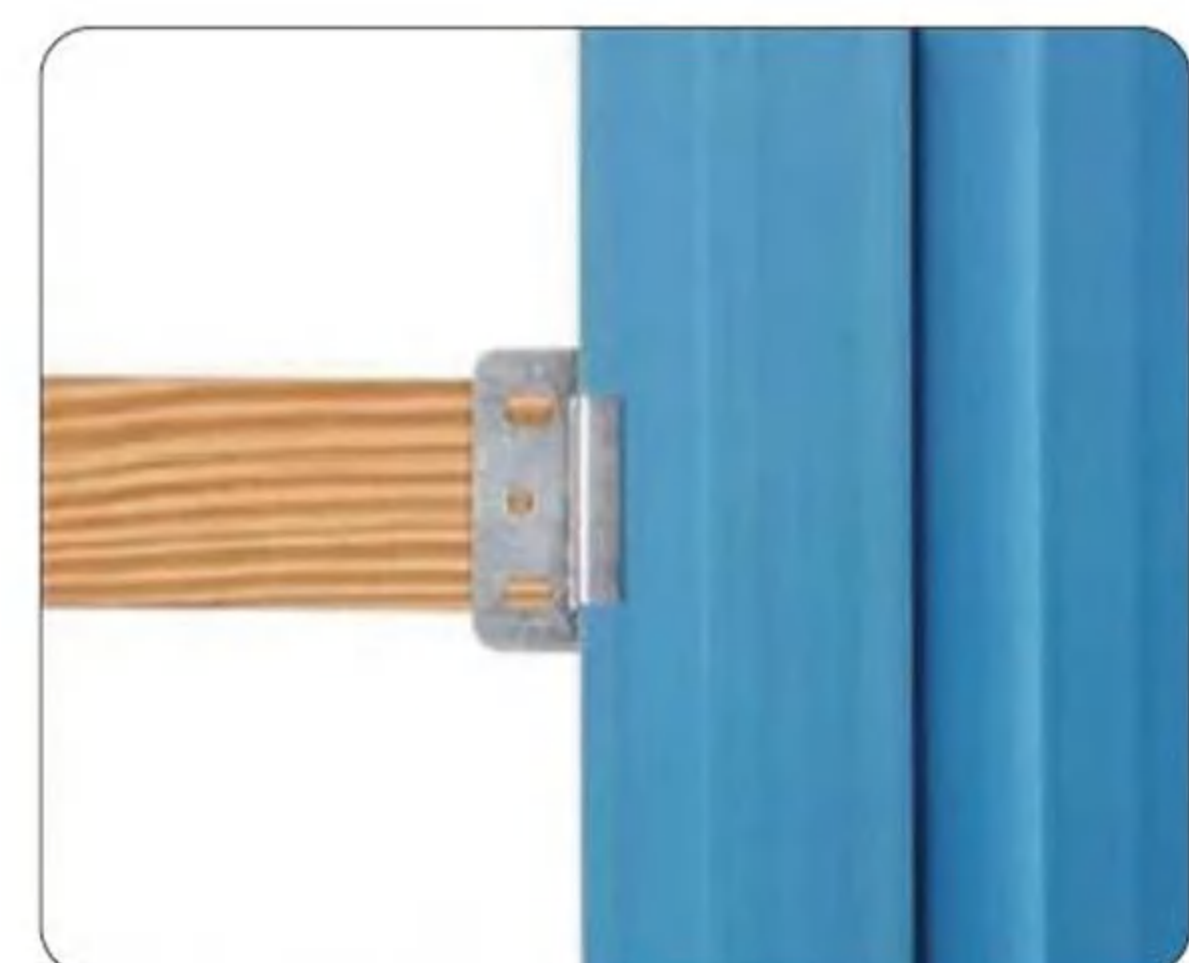

02 WPC Ceiling

Hot-selling product series

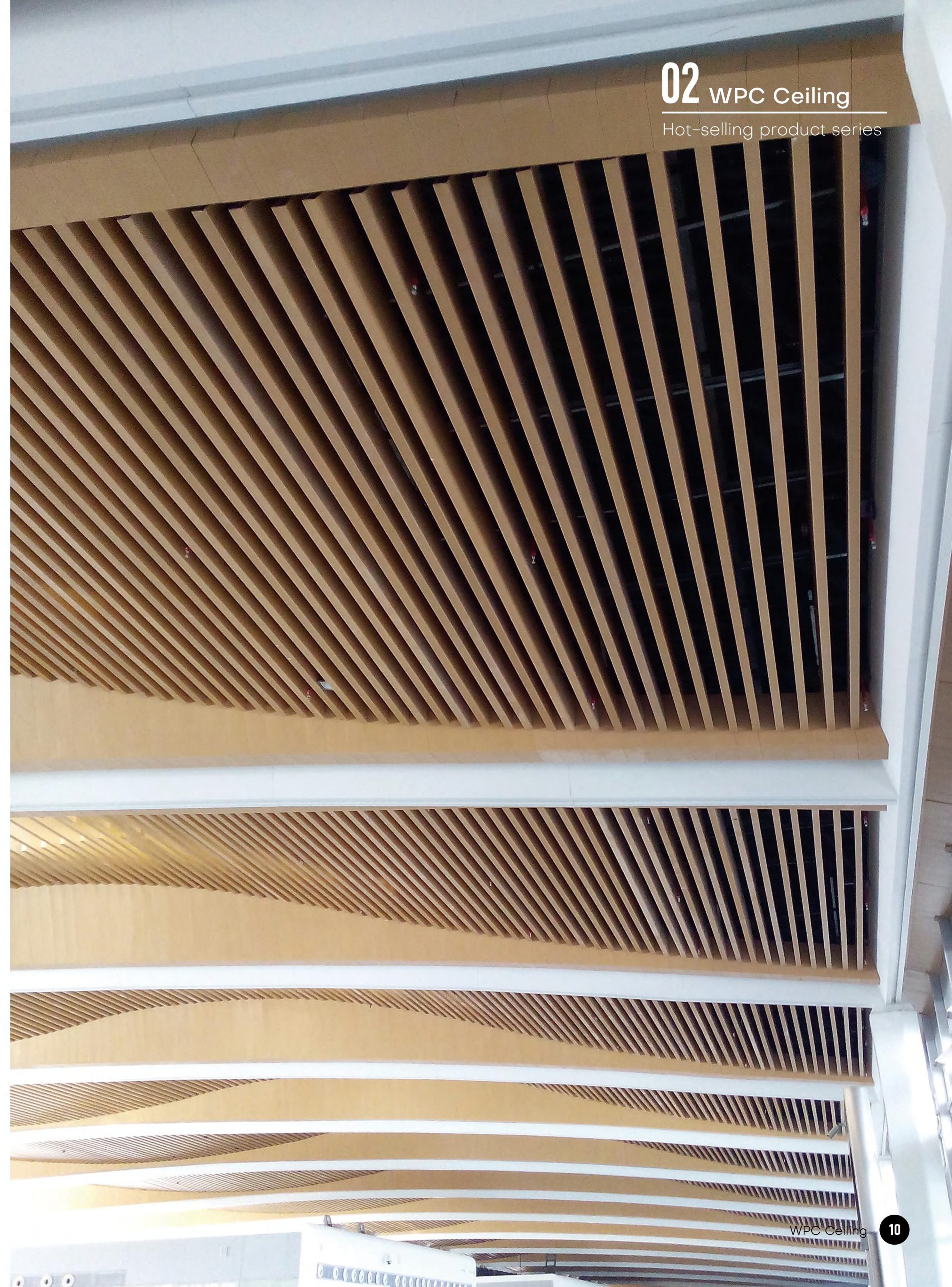

The ecological wood ceiling is a type of ecological wood product, essentially artificial wood. It is a kind of "greener wood plastic composite material," which is a mixture of resin, wood fiber material, and polymer material in specific proportions. Compared to logs, ecological wood has good stability, retains the physical characteristics of solid wood, and is waterproof, anti-corrosive, and provides heat insulation. Modifiers such as light and thermal stability, UV resistance, and low-temperature impact resistance are added during the production of ecological wood, giving it strong weather resistance and UV protection.

CSW2550
 W 25mm
 H 50mm
 L 2900mm



CSW4025
 W 40mm
 H 25mm
 L 2900mm



CSW4045
 W 40mm
 H 45mm
 L 2900mm



CSW4060
 W 40mm
 H 60mm
 L 2900mm



CSW5060
 W 50mm
 H 60mm
 L 2900mm

CSW4075
 W 40mm
 H 75mm
 L 2900mm

CSW5075
 W 50mm
 H 75mm
 L 2900mm

CSW4080
 W 40mm
 H 80mm
 L 2900mm

CSW5090
 W 50mm
 H 90mm
 L 2900mm

CSW40100
 W 40mm
 H 100mm
 L 2900mm

CSW50100
 W 50mm
 H 100mm
 L 2900mm

Accessories



Keel



Hanger

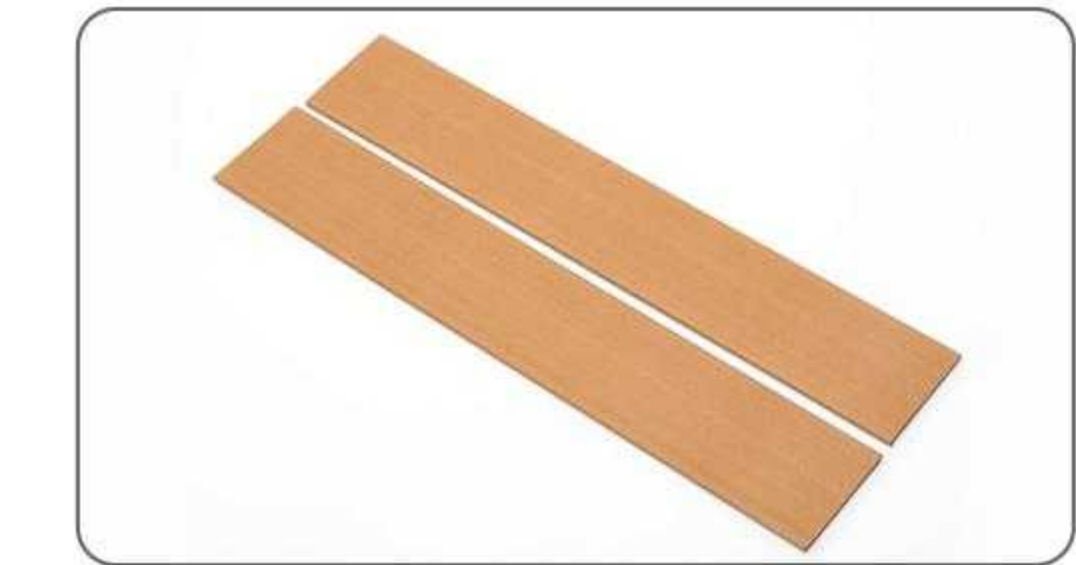

Shutter

Installation structure

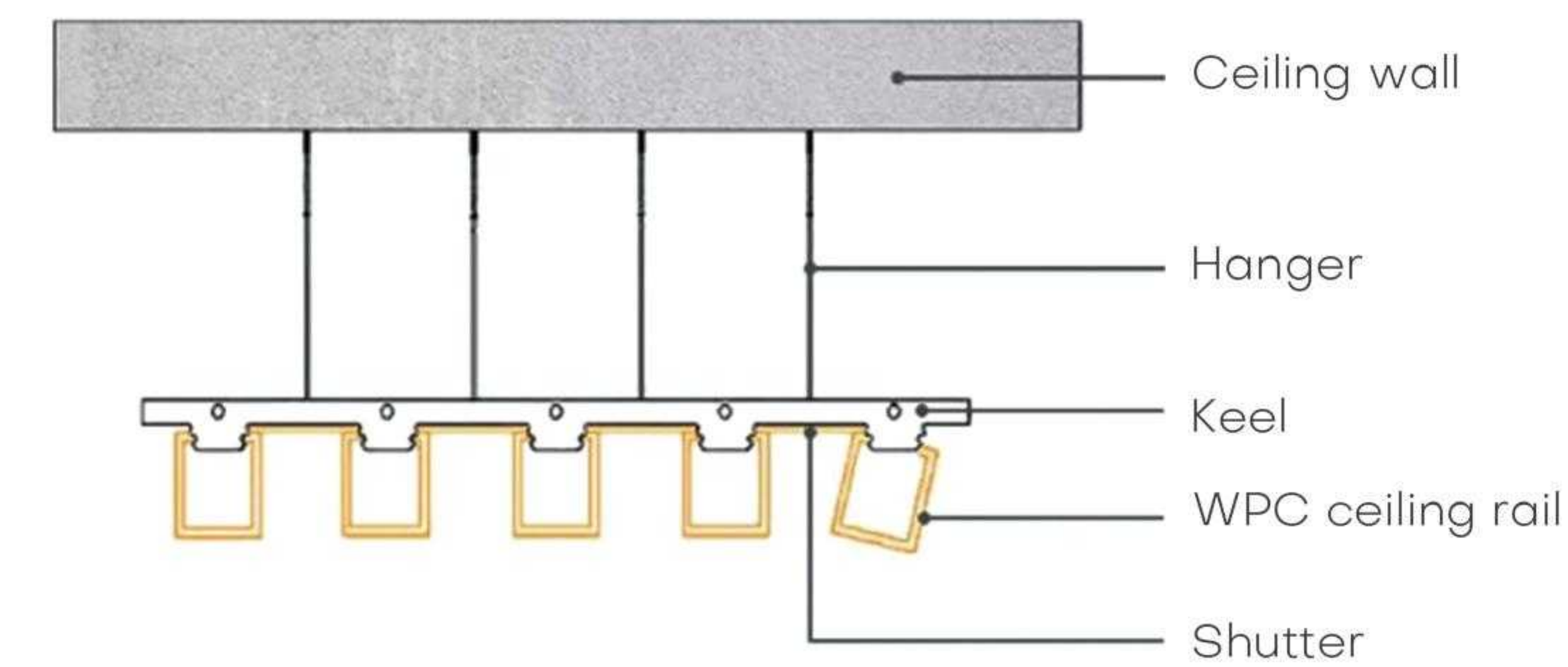

Installation

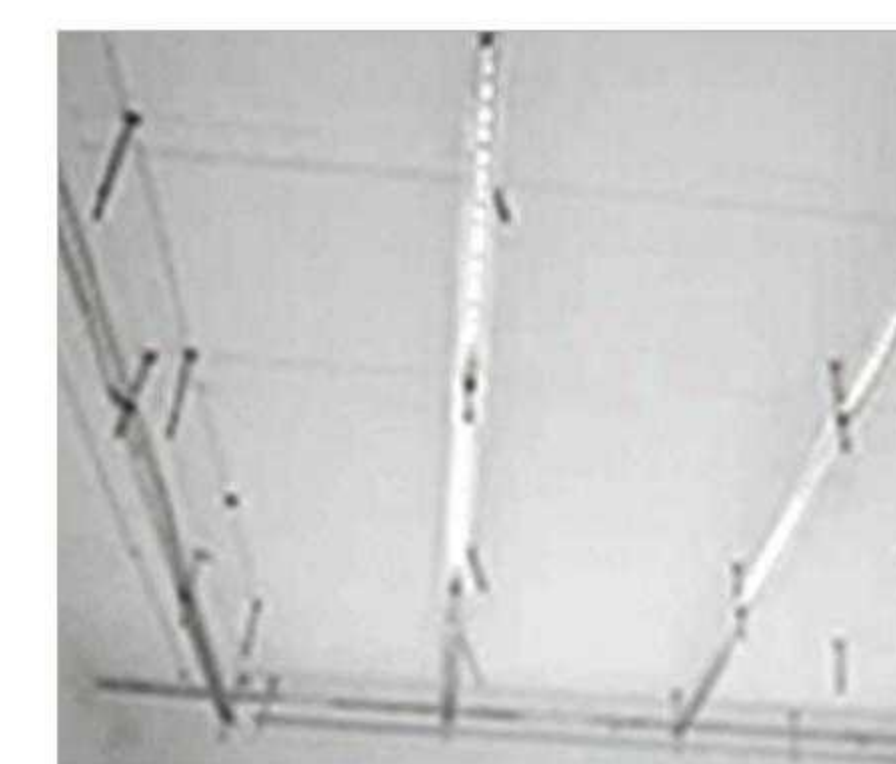

Positioning and punching

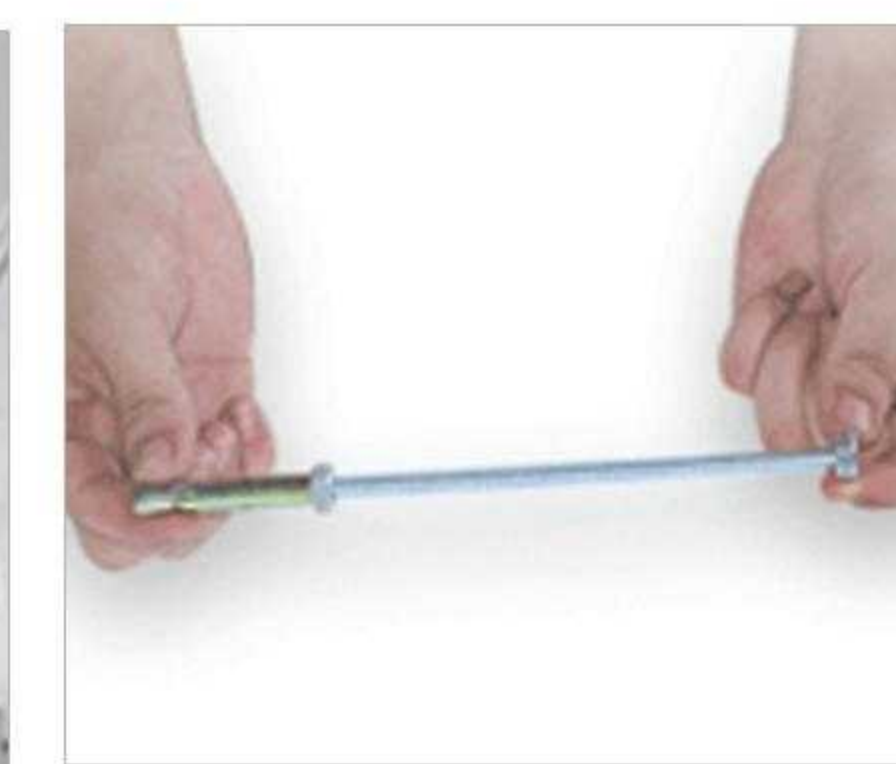

Install hangers



Fixed keel



Install the ceiling on the keel

03 WPC Timber Tube

Hot-selling product series

WPC (Wood Plastic Composite) timber tubes are composite materials made from a blend of wood fibers or wood flour and thermoplastics, typically polyethylene, polypropylene, or PVC. This combination results in a product that mimics the appearance of natural wood while providing the benefits of plastic, such as enhanced durability and resistance to environmental factors.



CSW4025

W 40mm
H 25mm
L 2900mm

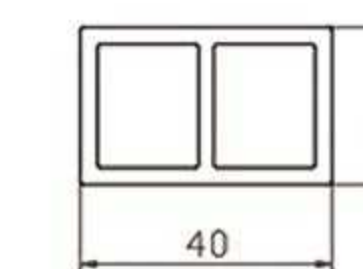

CSW7550

W 75mm
H 50mm
L 2900mm

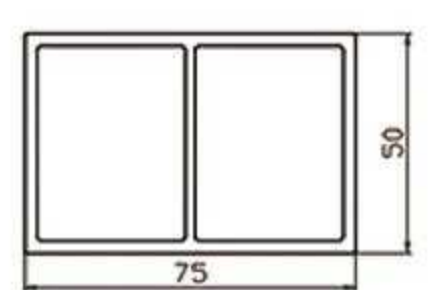

CSW5025

W 50mm
H 25mm
L 2900mm

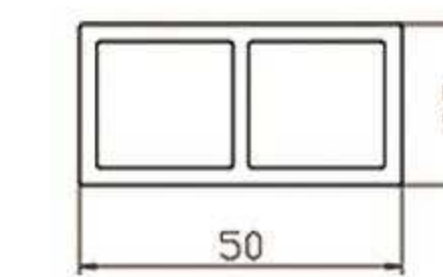

CSW10050

W 100mm
H 50mm
L 2900mm

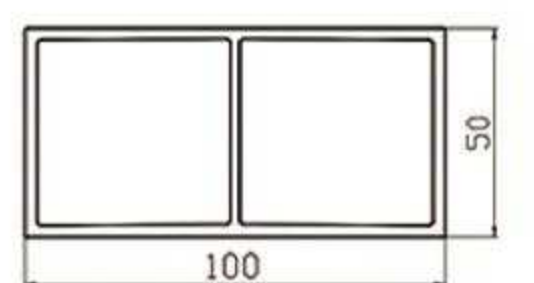

CSW5040

W 50mm
H 40mm
L 2900mm

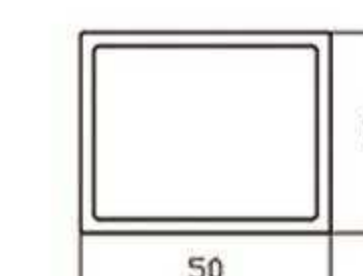

CSW10050

W 100mm
H 50mm
L 2900mm

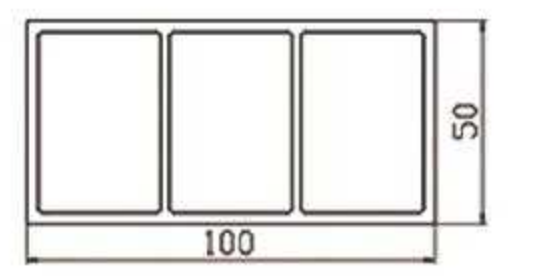

CSW5050

W 50mm
H 50mm
L 2900mm

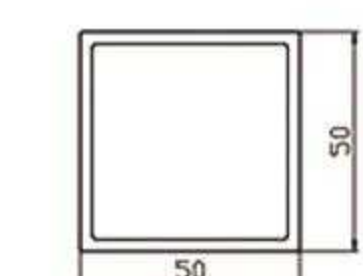

CSW100100

W 100mm
H 100mm
L 2900mm

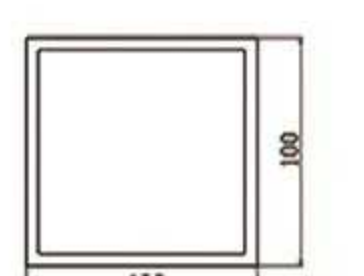

CSW6525

W 65mm
H 25mm
L 2900mm

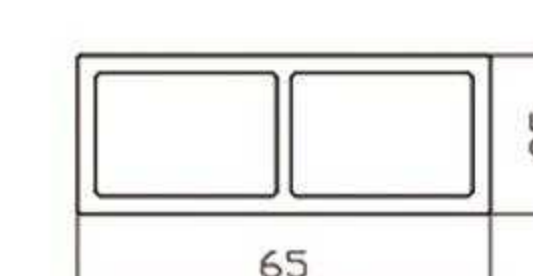

CSW15050

W 150mm
H 50mm
L 2900mm

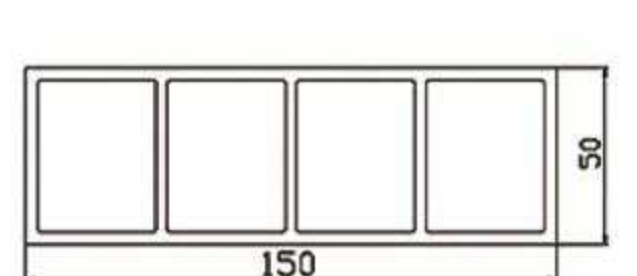

03 WPC Timber Tube

Installation Method

◦ Installation



1.Clean both ends of WPC timber tube and put glue in.

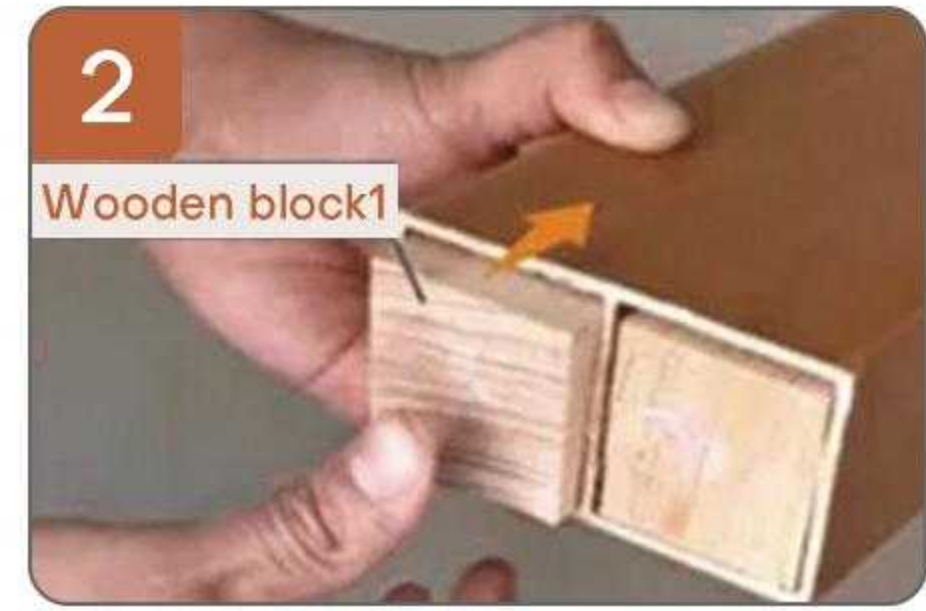

2.Insert the wooden block 1 which is 5cm in both ends of WPC timber tube.

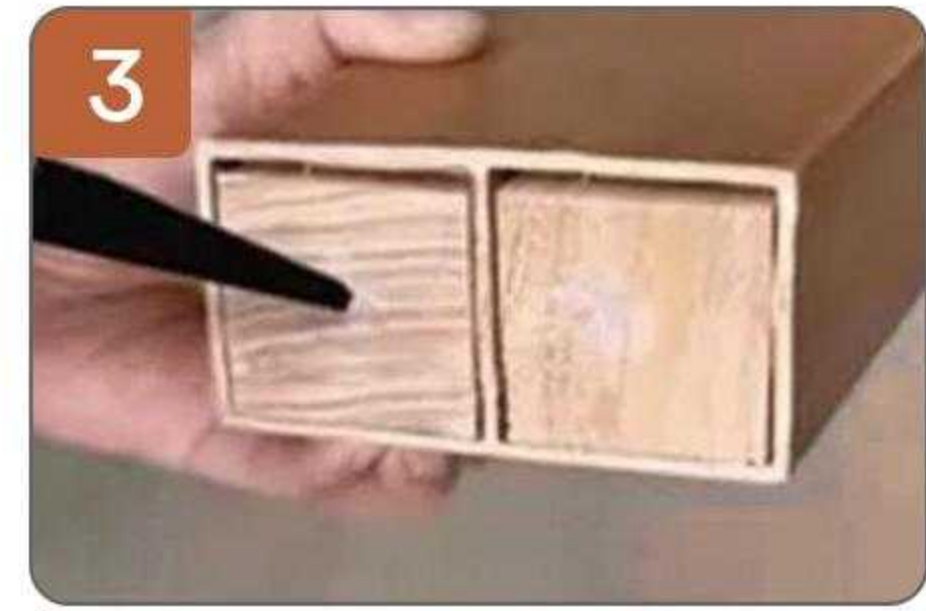
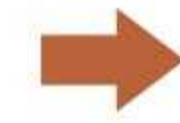

3.Put glue on both ends of the wooden block 1 for WPC timber tube.



4.Fix wooden block 2 on position of the ceiling floor by glue, and then put the WPC square tube on the position of wooden block 2, then finish.



04 WPC Foam Board

Hot-selling product series

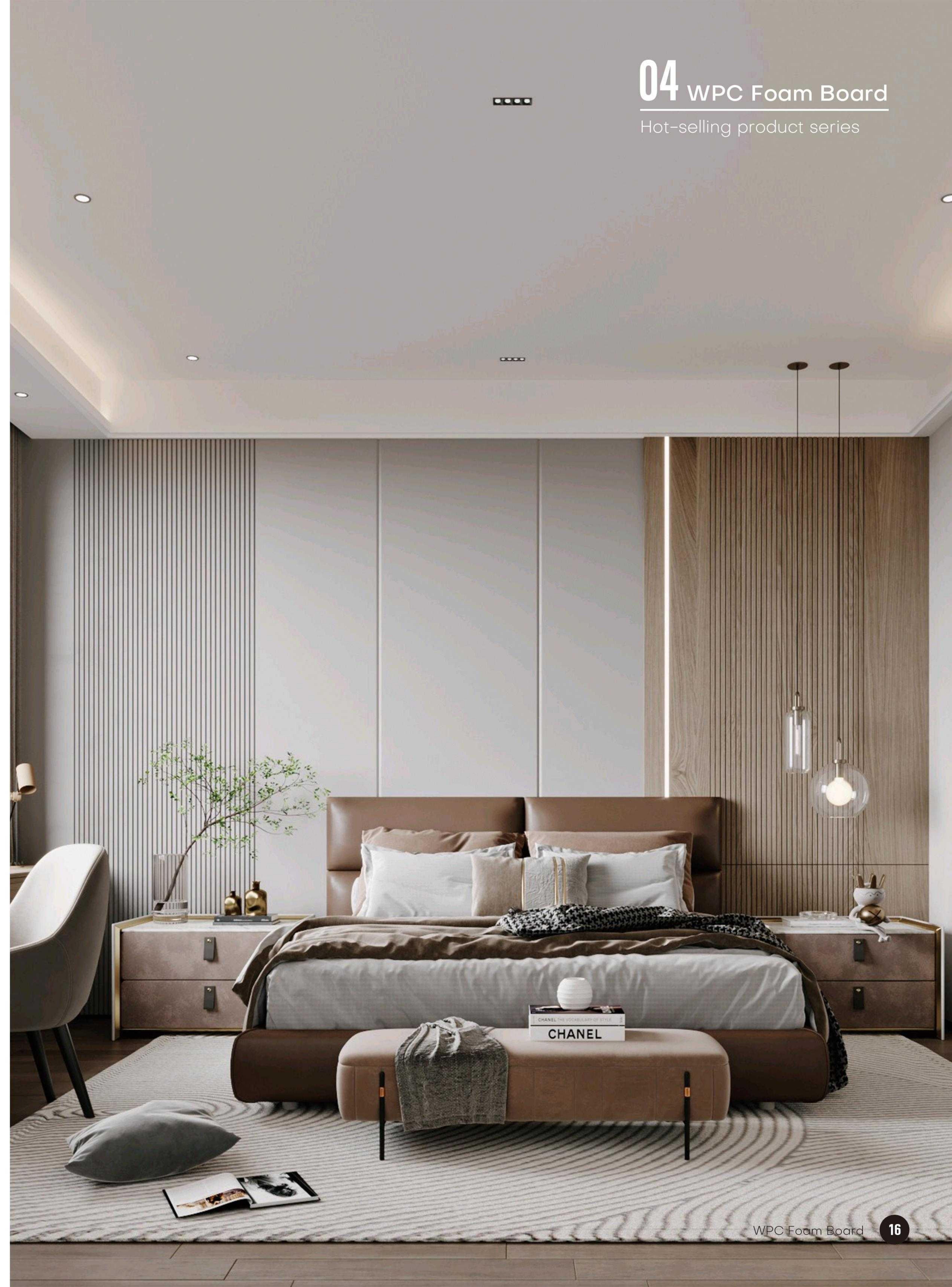

04 WPC Foam Board

Hot-selling product series

WPC foam board is made of polyvinyl chloride resin, combined with wood powder and special additives, then extruded. It is a waterproof, lightweight, expanded rigid plastic board suitable for various applications, including kitchen and bathroom cabinets, interior decoration, booths, advertising signs and displays, prototypes, and more.

Due to its high workability, WPC foam board can be easily processed by sawing, CNC cutting, printing, sanding, routing, painting, laminating, and other methods.

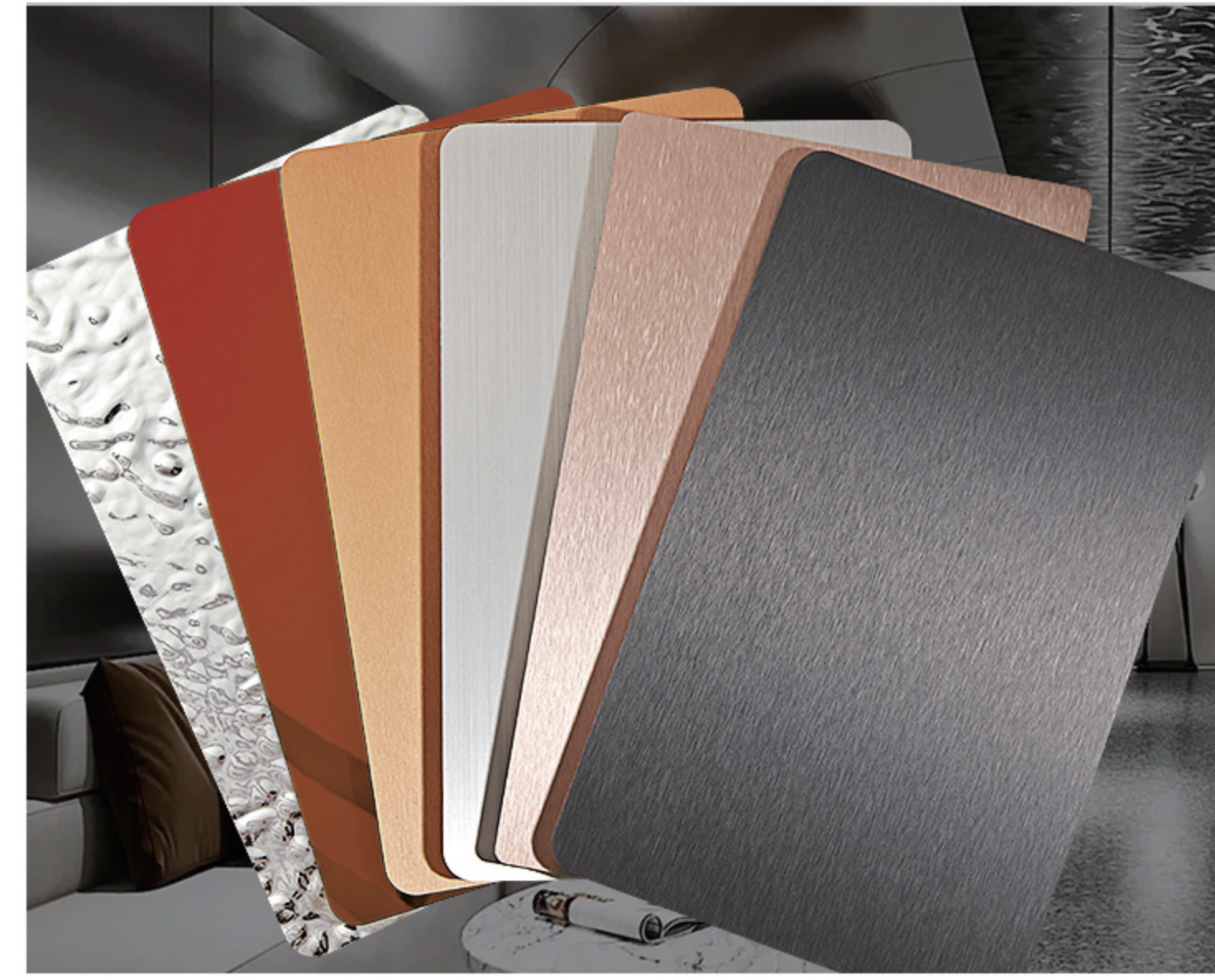

◦ Splicing method

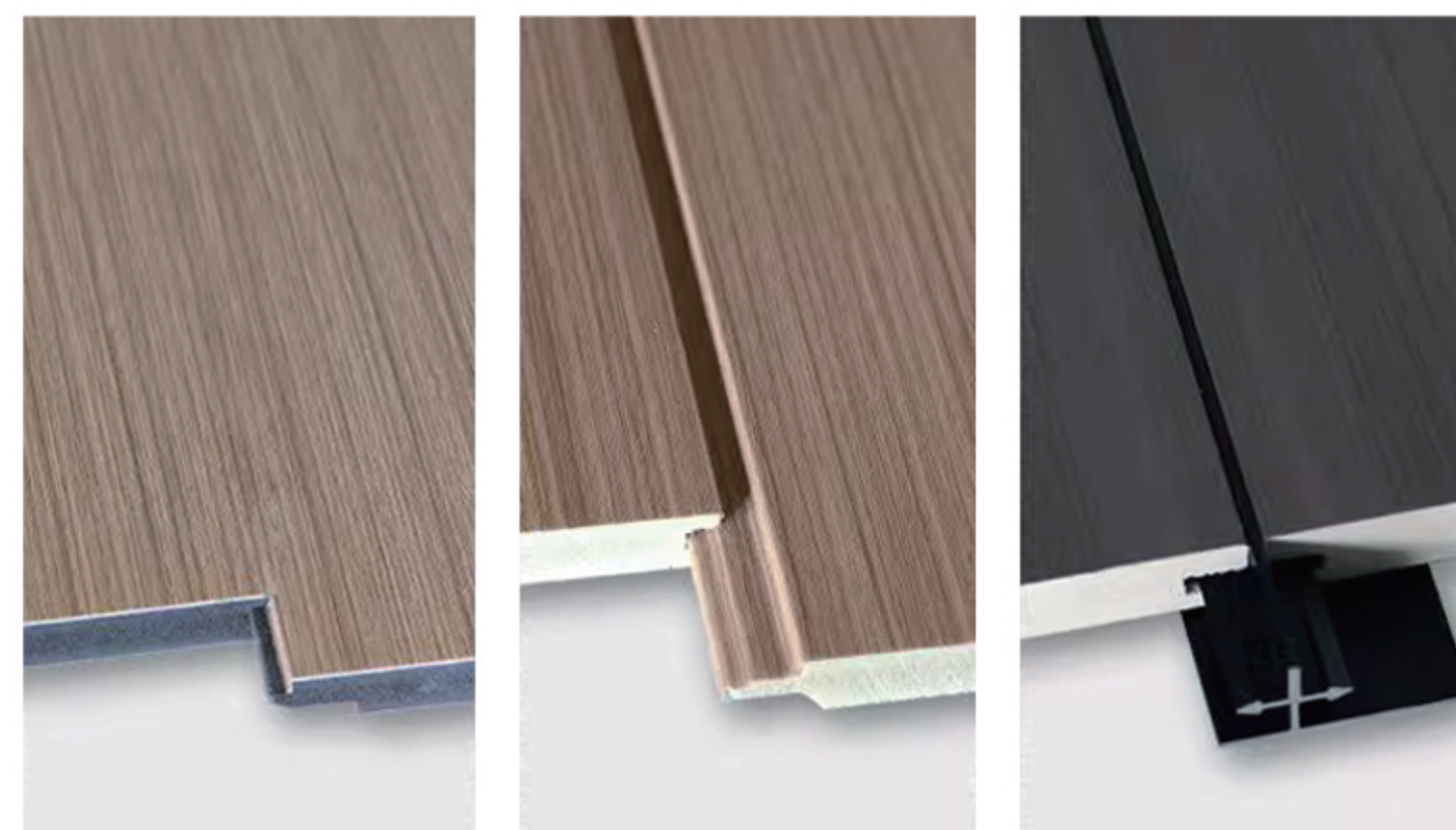
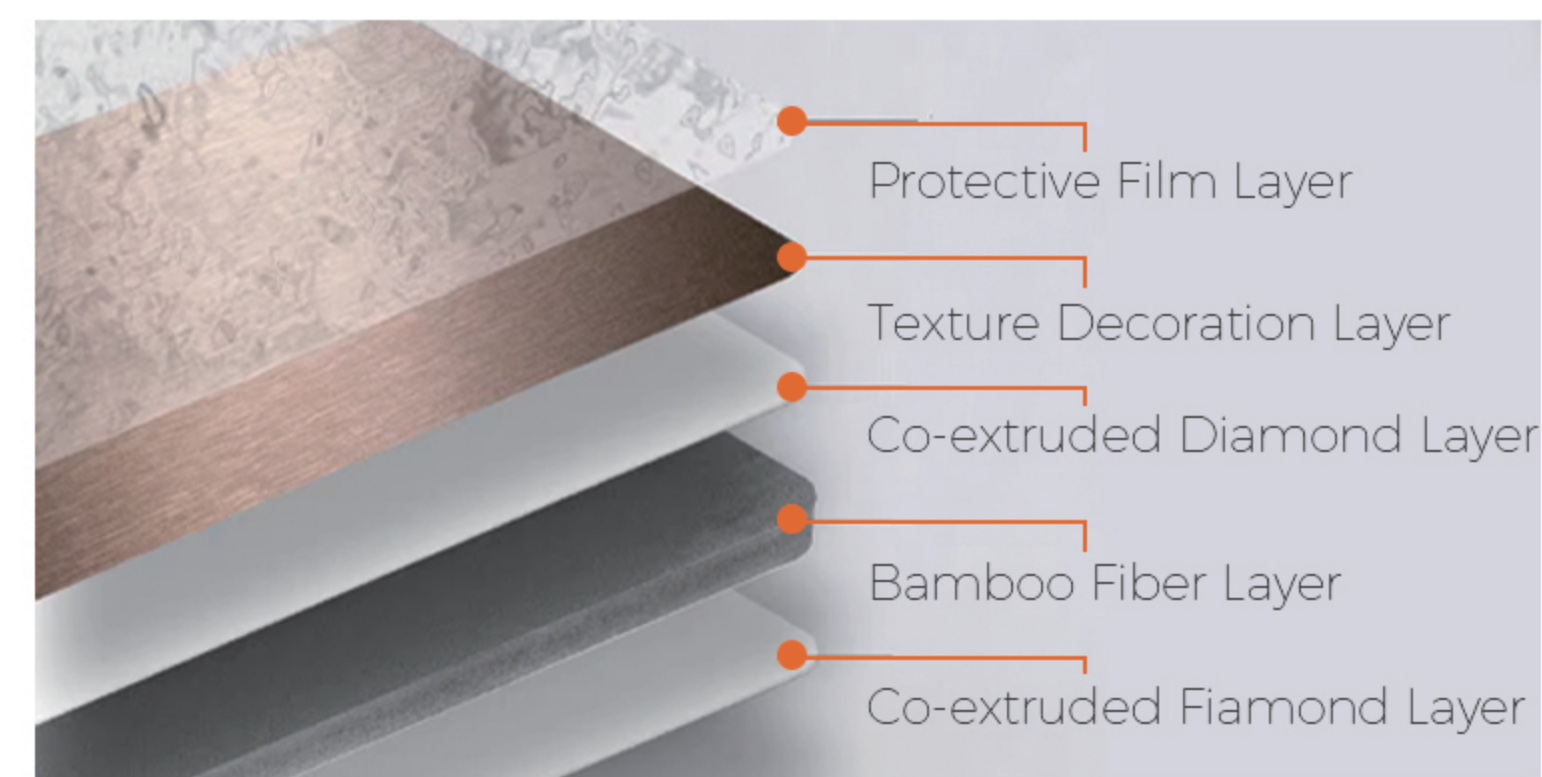

Flat Seam Channel U-shaped Channel Double Female Channel

◦ Bendable and chamferable

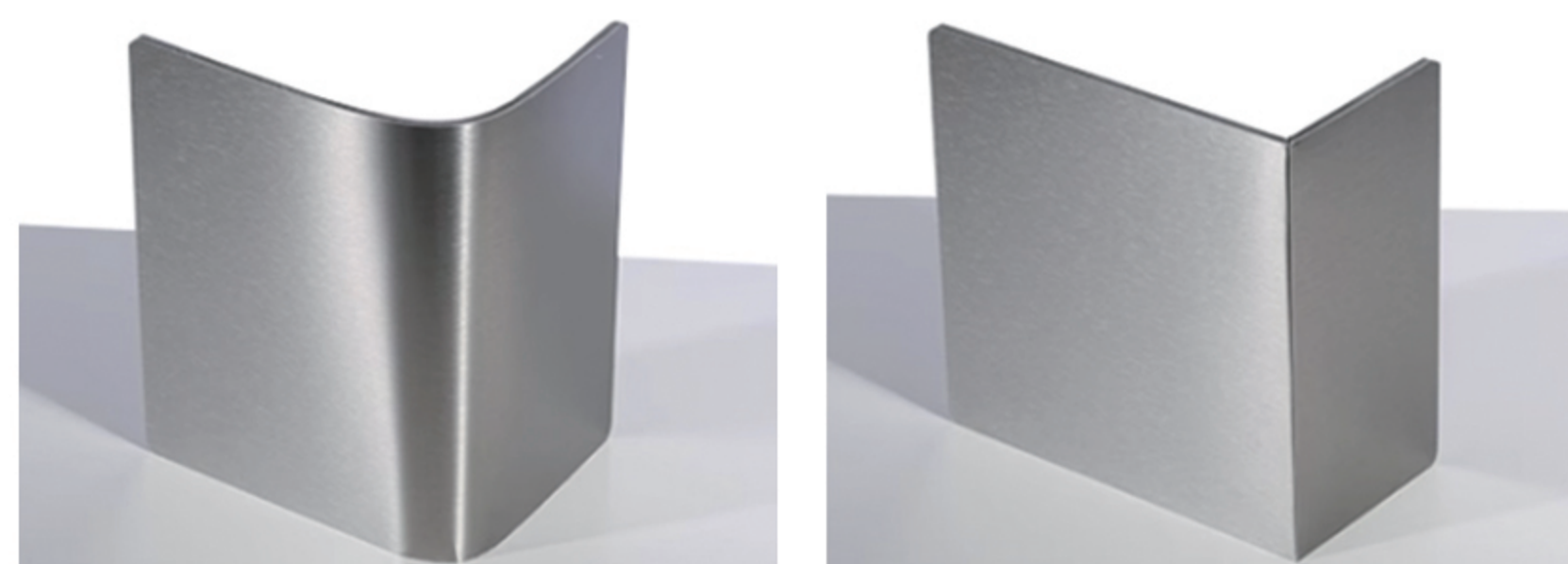

◦ Matching lines

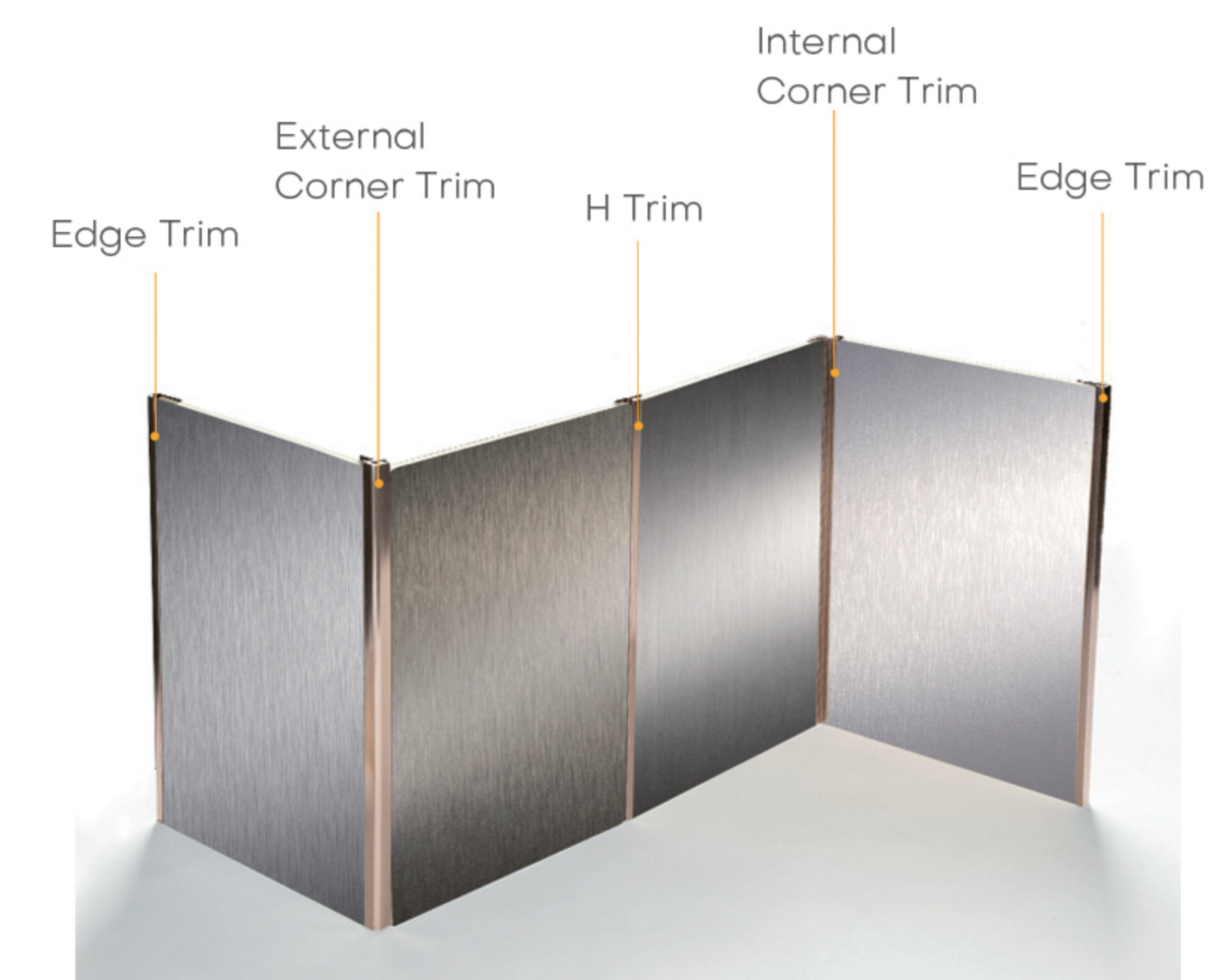

PVC Film

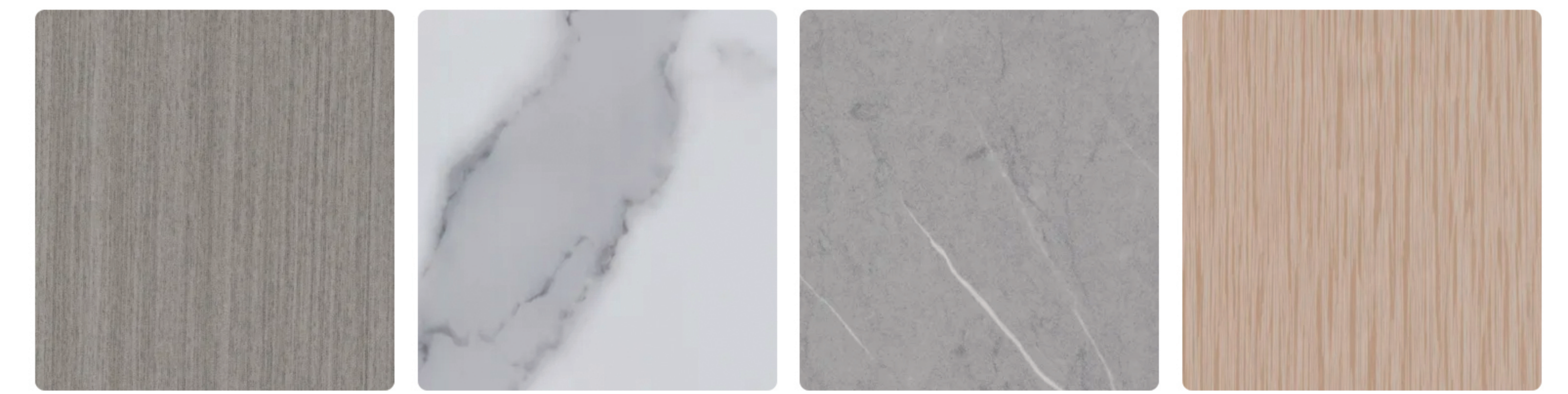

L-001 L-002 L-003 L-004



L-005 L-006 L-007 L-008

Continuous PET Pattern

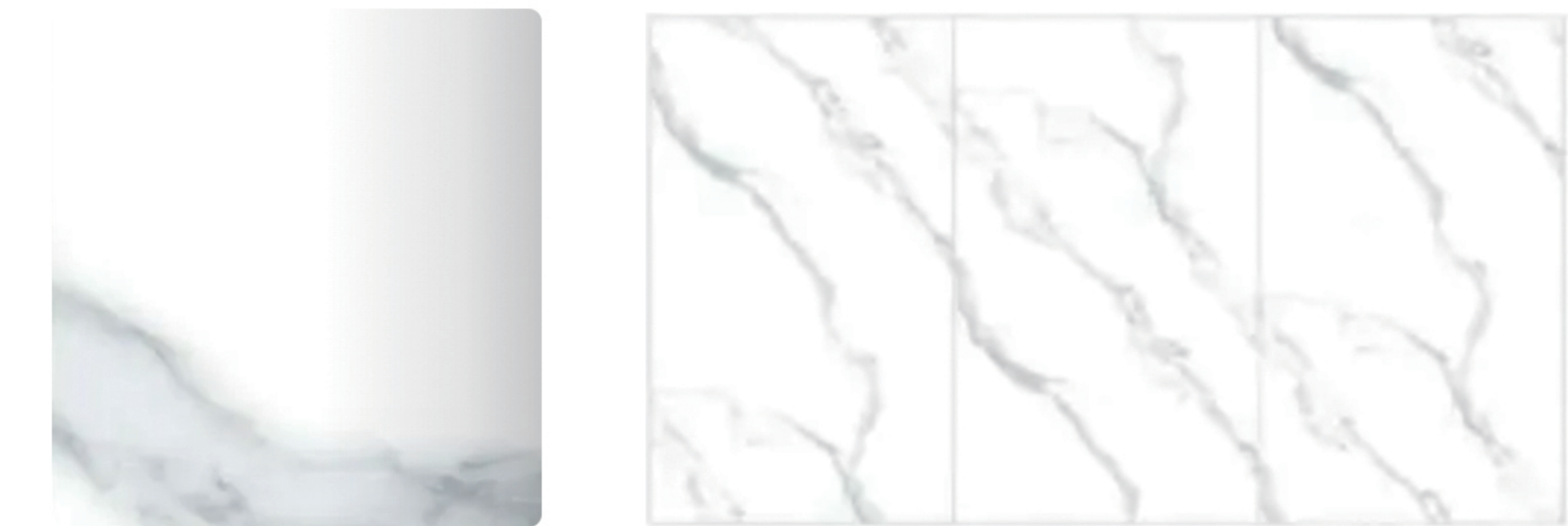

H-001

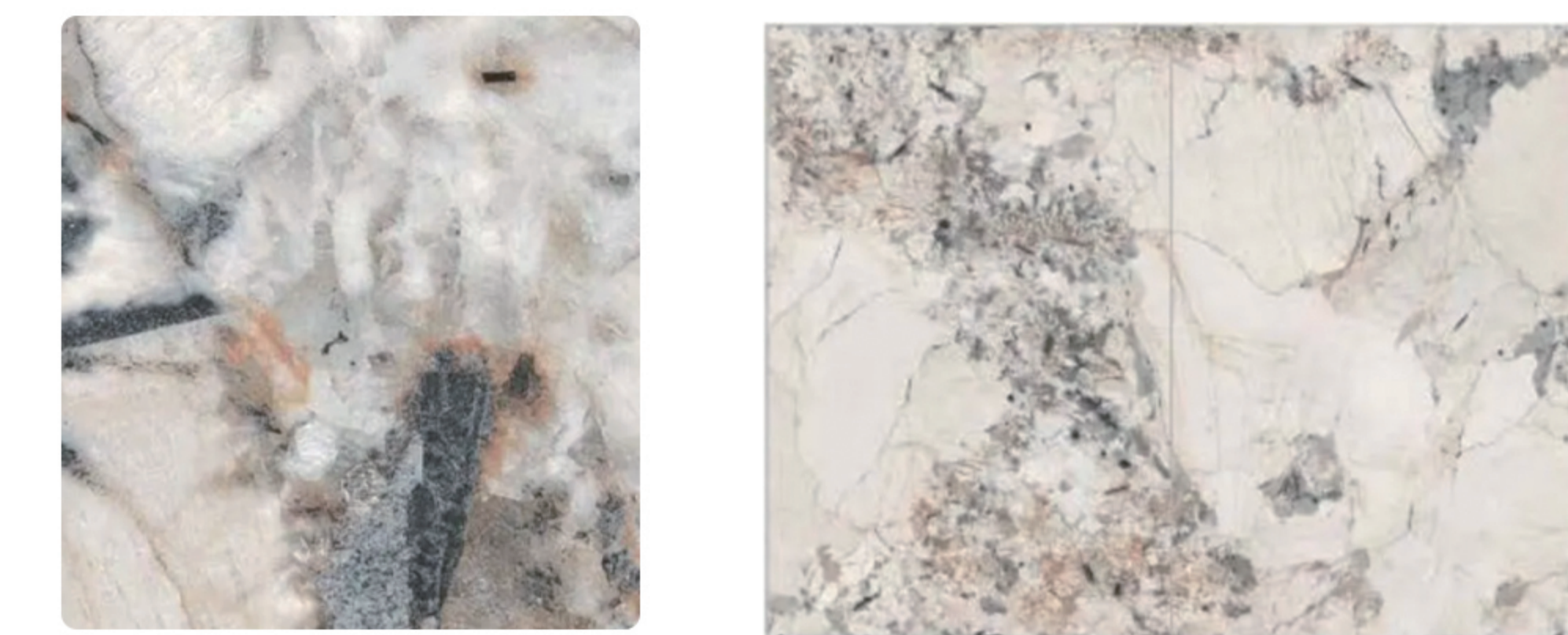

H-002

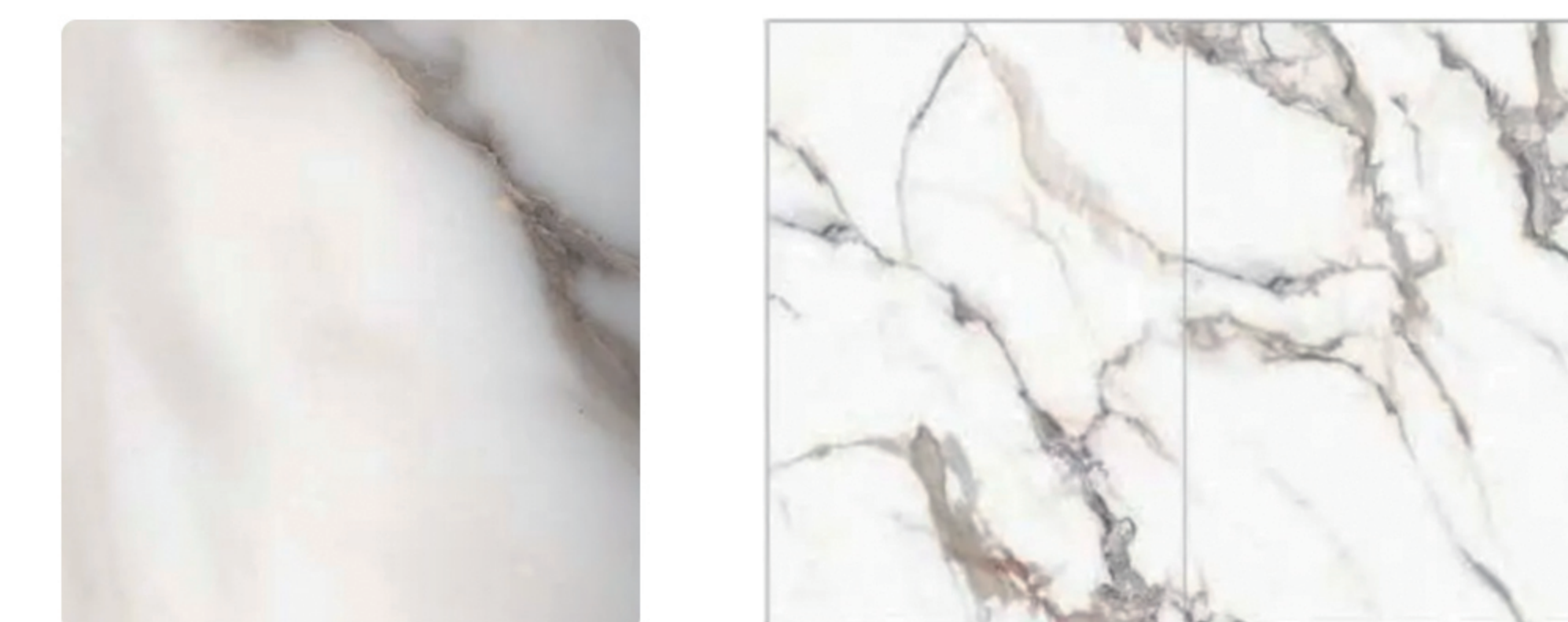

H-003

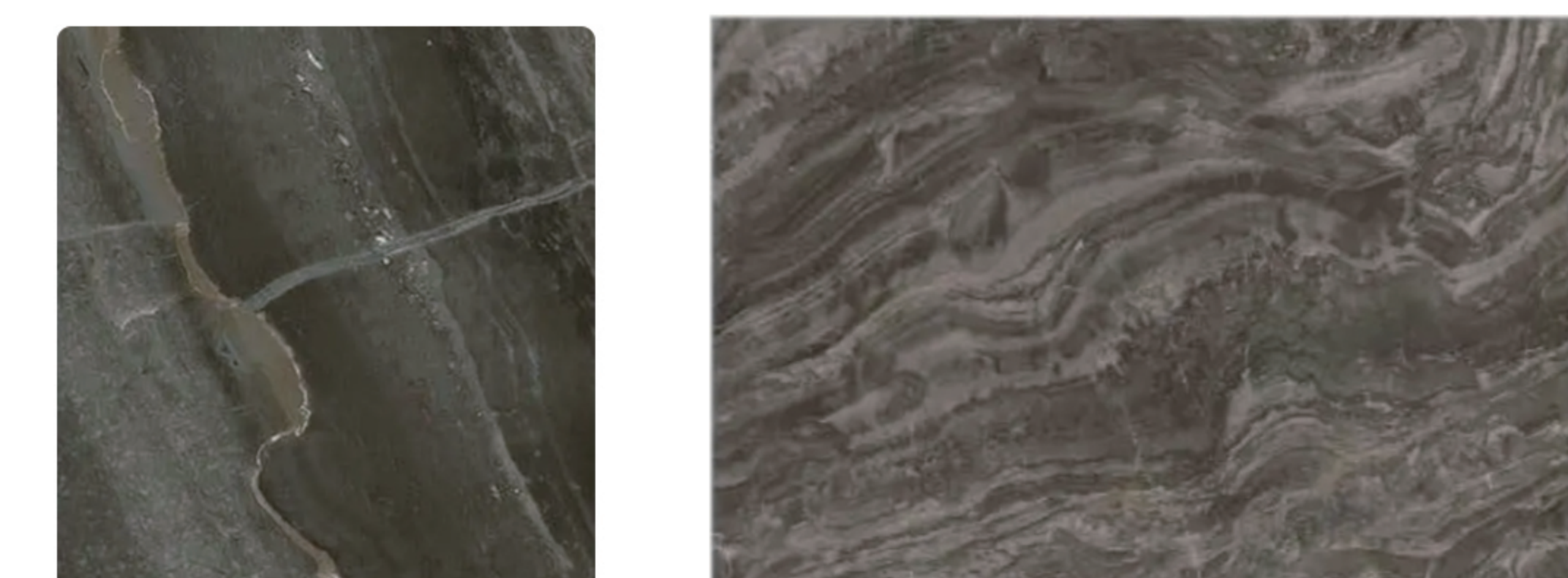

H-004

| | |
|--------------------|--|
| Material | Wood plastic composite |
| Thickness | 5/8/10/12/15/17/18mm, other thickness between 3-30mm. |
| Size | 1220*2440mm(4*8feet),customized |
| Processing Service | Cutting,Curving,Packing,etc. |
| Density | 0.5-0.9tons/m ³ |
| Colour | Wooden Color |
| Applications | Flooring,cladding,false ceiling, sunshade louvers,pergola,gazebo,etc. |

- Fire-resistant Flame-retardant
- Waterproof Moisture-proof
- Eco-friendly
- Soundproof Noise-reducing
- Thermal insulation
- Easy to install

04 WPC Foam Board

Hot-selling product series

Skin Feel

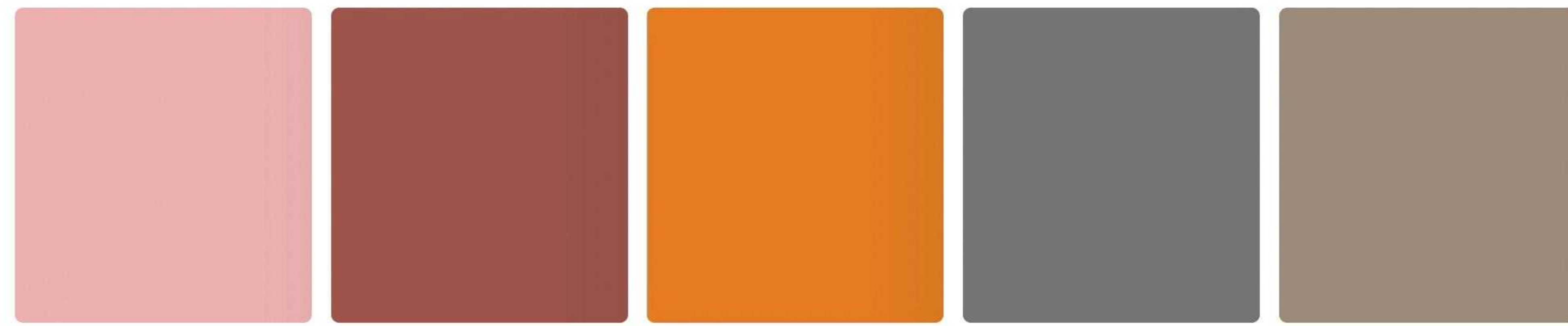

S-001 S-002 S-003 S-004 H-101

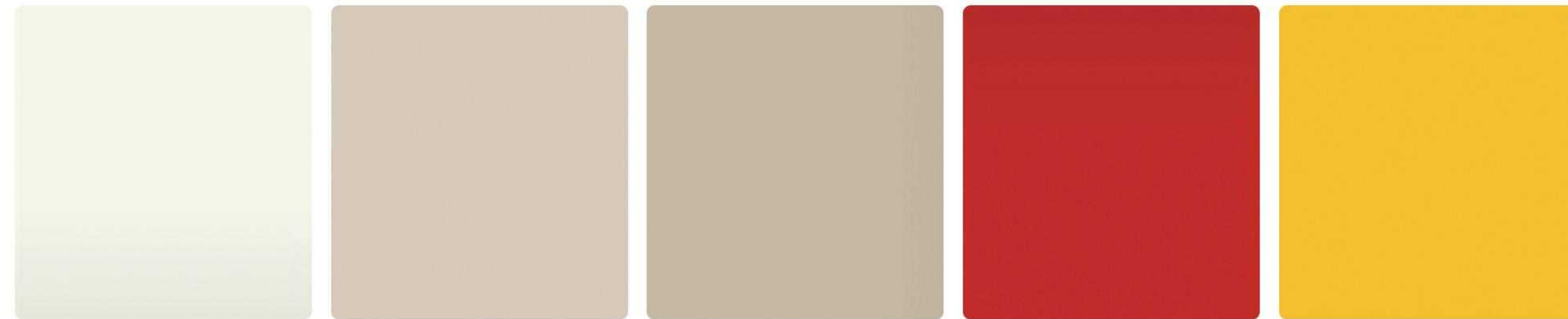

H-102 H-103 H-104 H-105 H-106

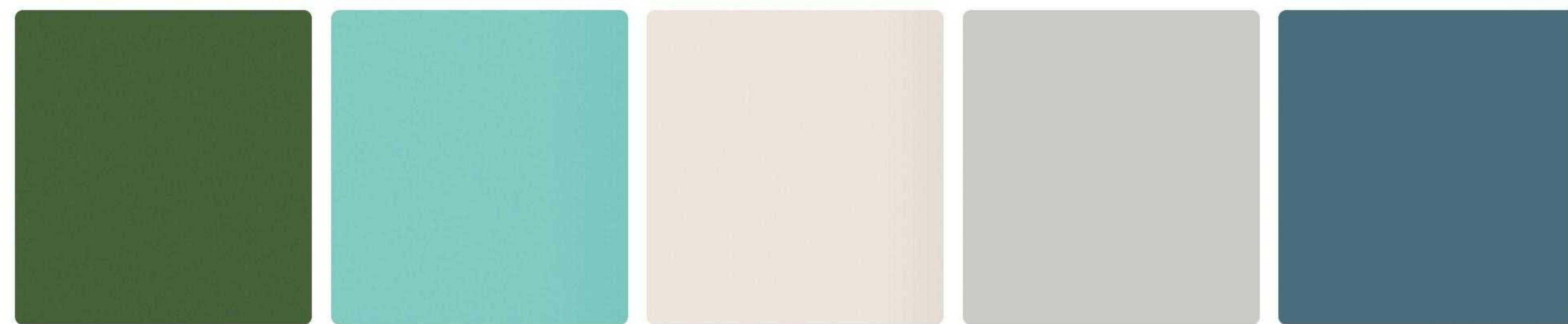

H-107 H-108 R-001 R-002 R-003

Baby's Breath

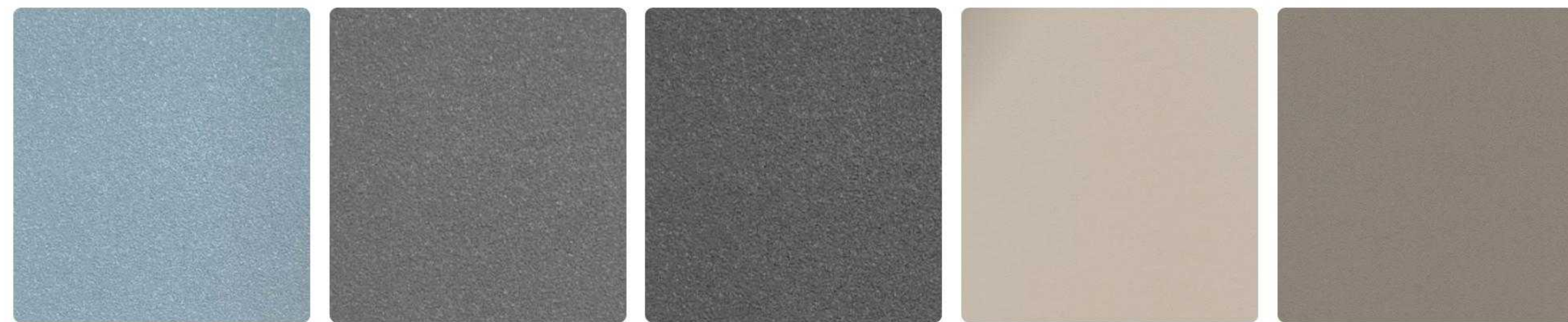

S-101 S-102 S-103 H-201 H-202

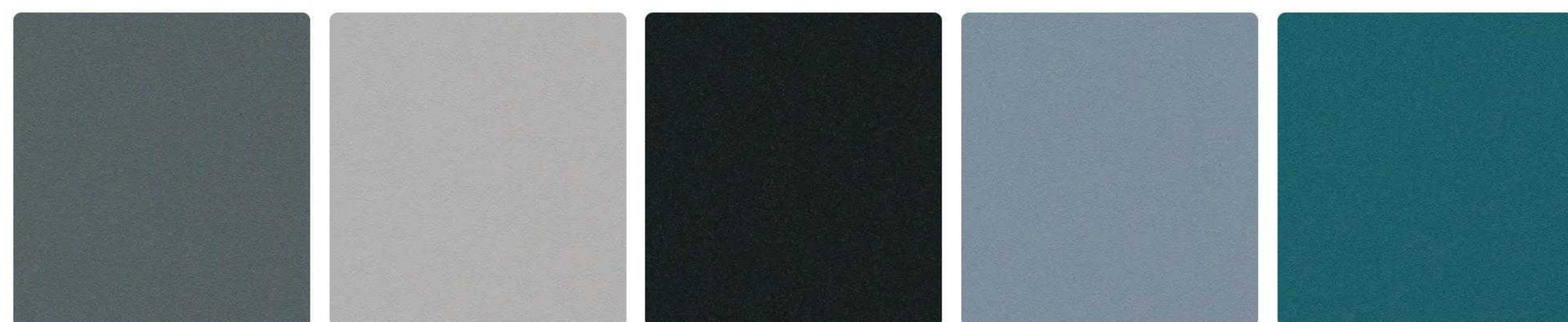

H-203 H-204 H-205 H-206 H-207

Metal Wire-Drawing

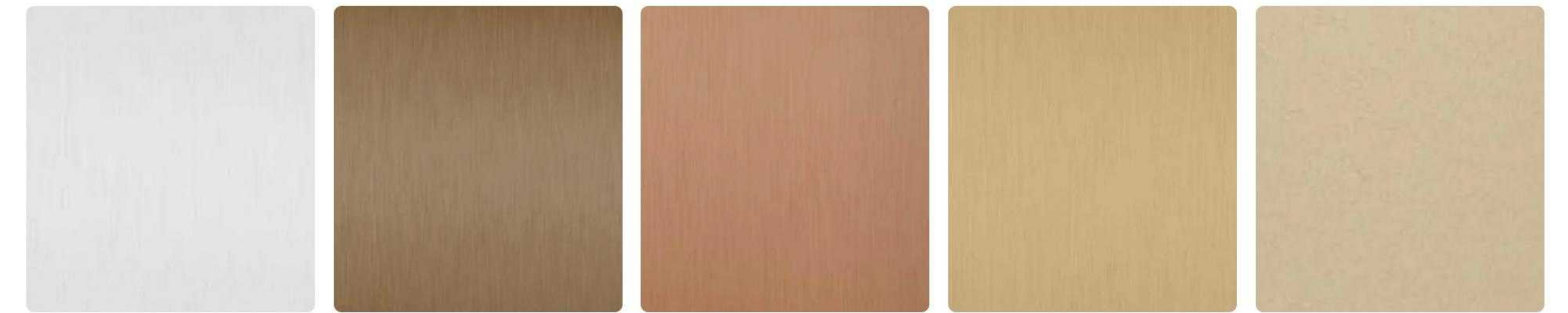

H-301 H-302 H-303 H-304 H-305



H-306 H-307 H-308 H-309 H-310

Mirror



S-201 S-202 S-203 S-204 S-205



S-206 S-207

Water Ripple

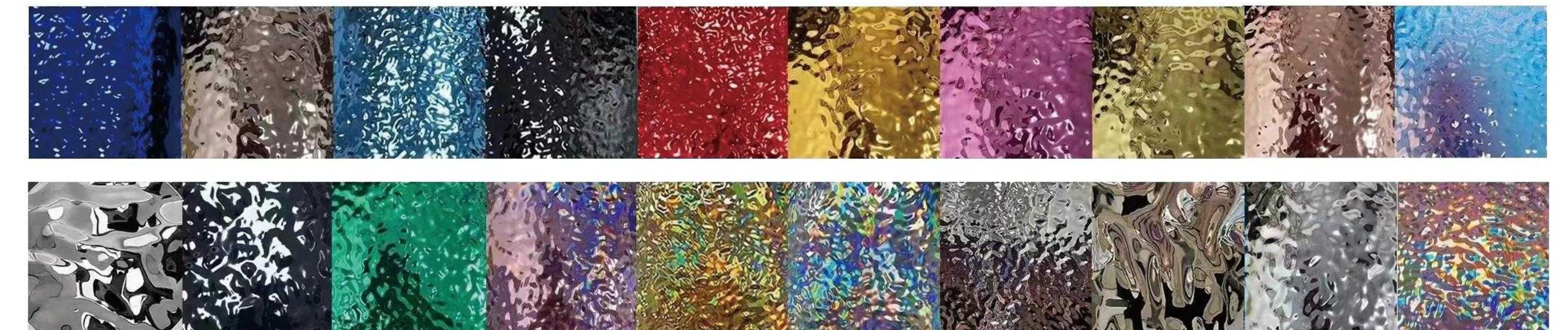

04 WPC Foam Board

Hot-selling product series

Color Focus



L-101 L-102 L-103 L-104 L-105 L-106

Laser



L-201 L-202 L-203 L-204 L-205

Mosaic

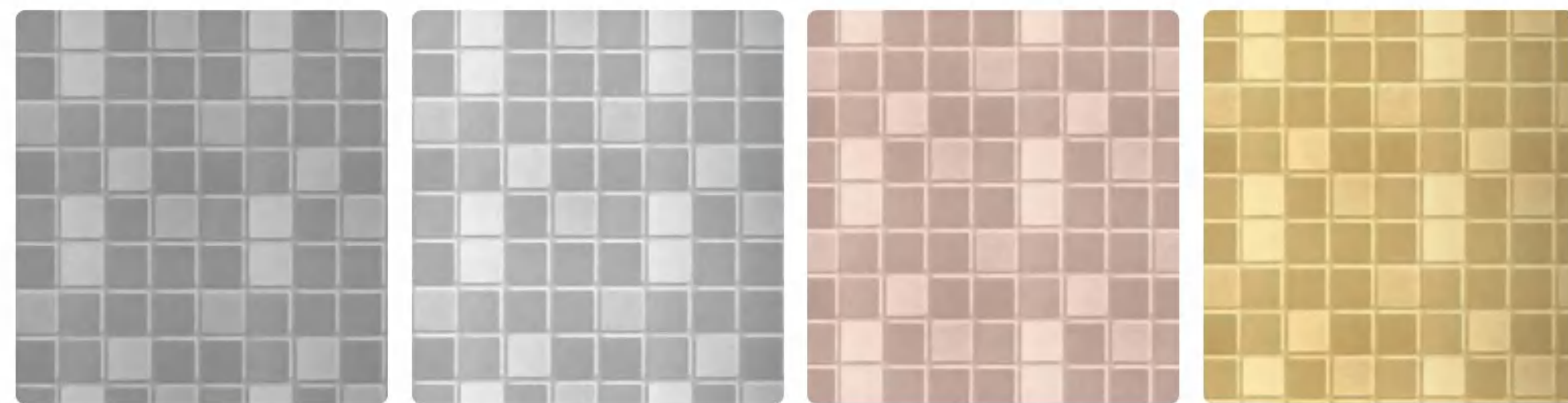

H-401 H-402 H-403 H-404

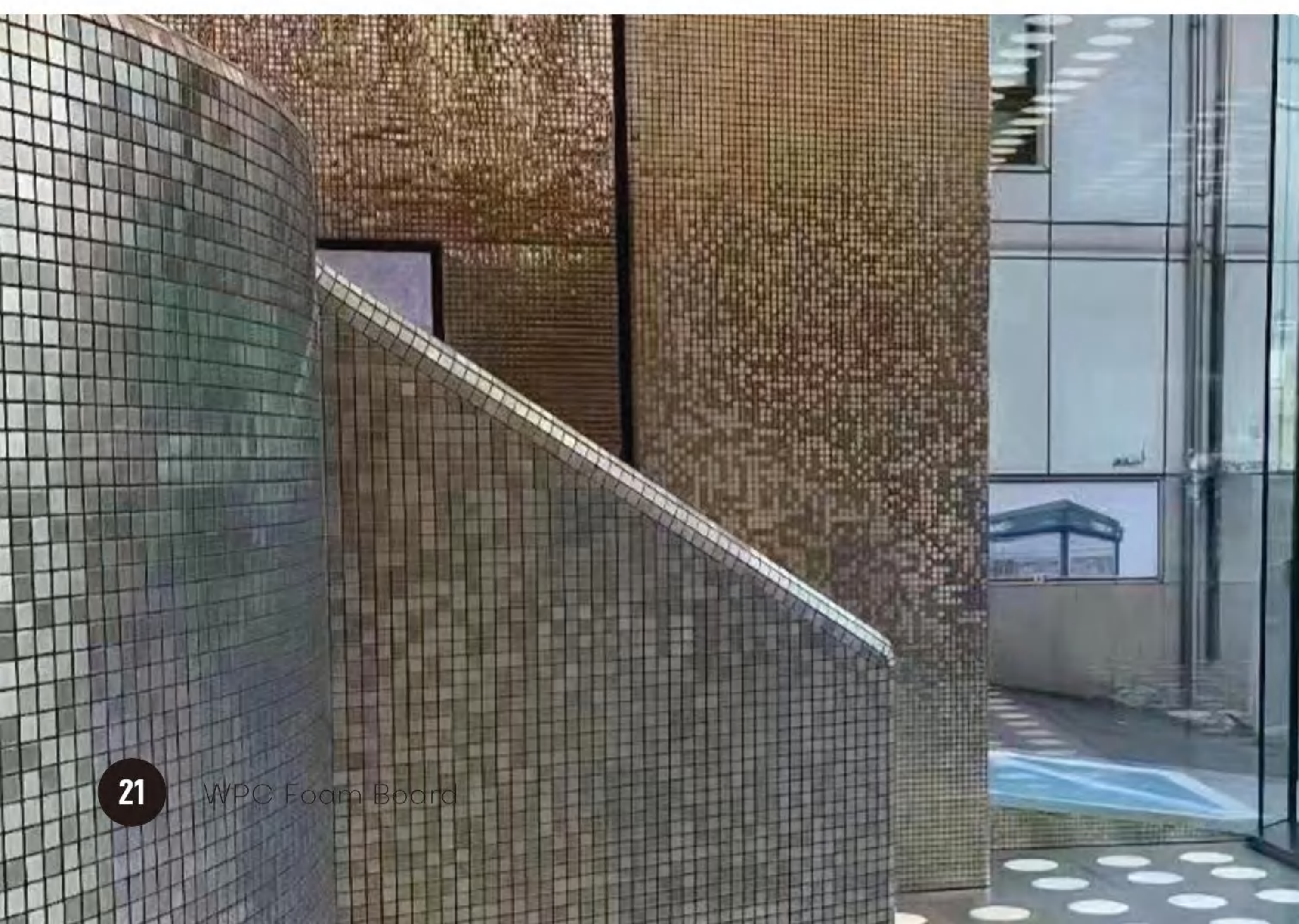

04 WPC Foam Board

Hot-selling product series



04 WPC Foam Board

Installation Method

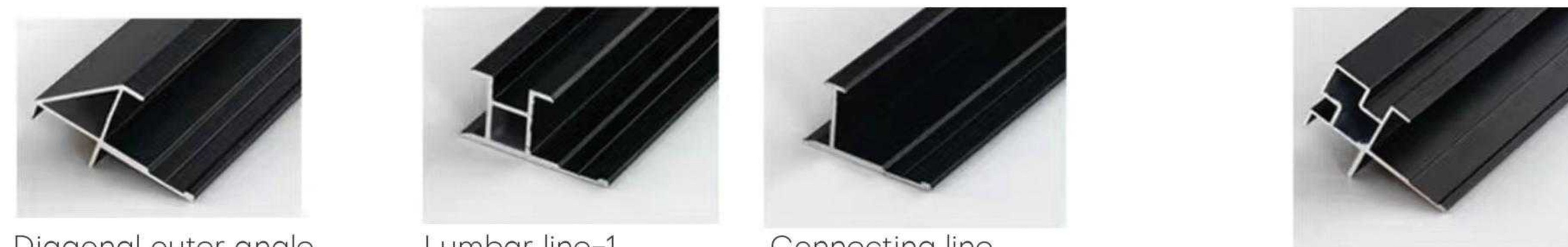
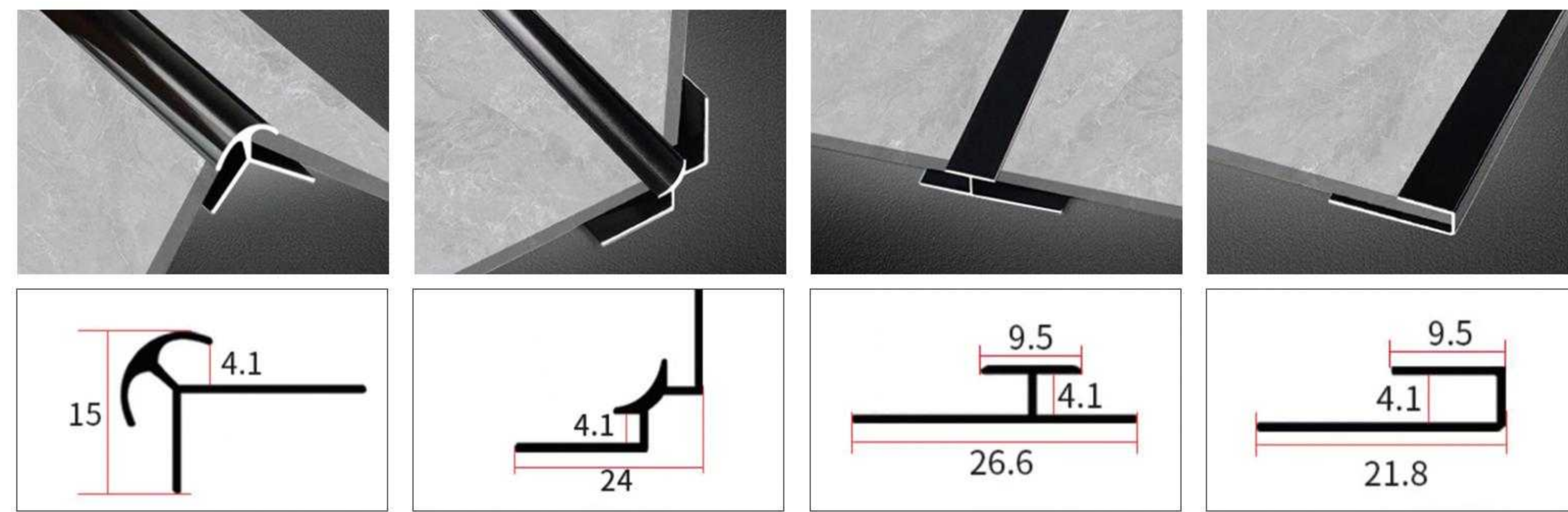

Diagonal outer angle Lumbar line-1 Connecting line Square outer angle-2

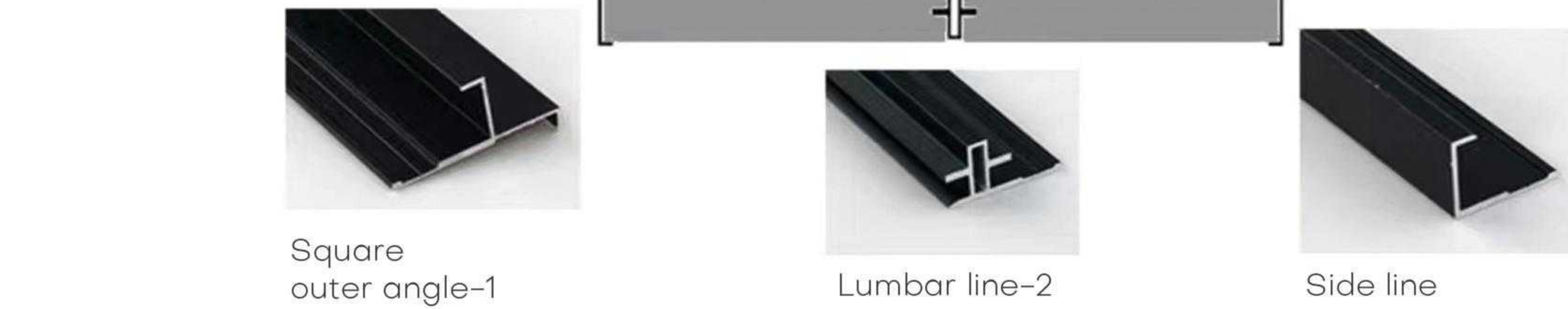
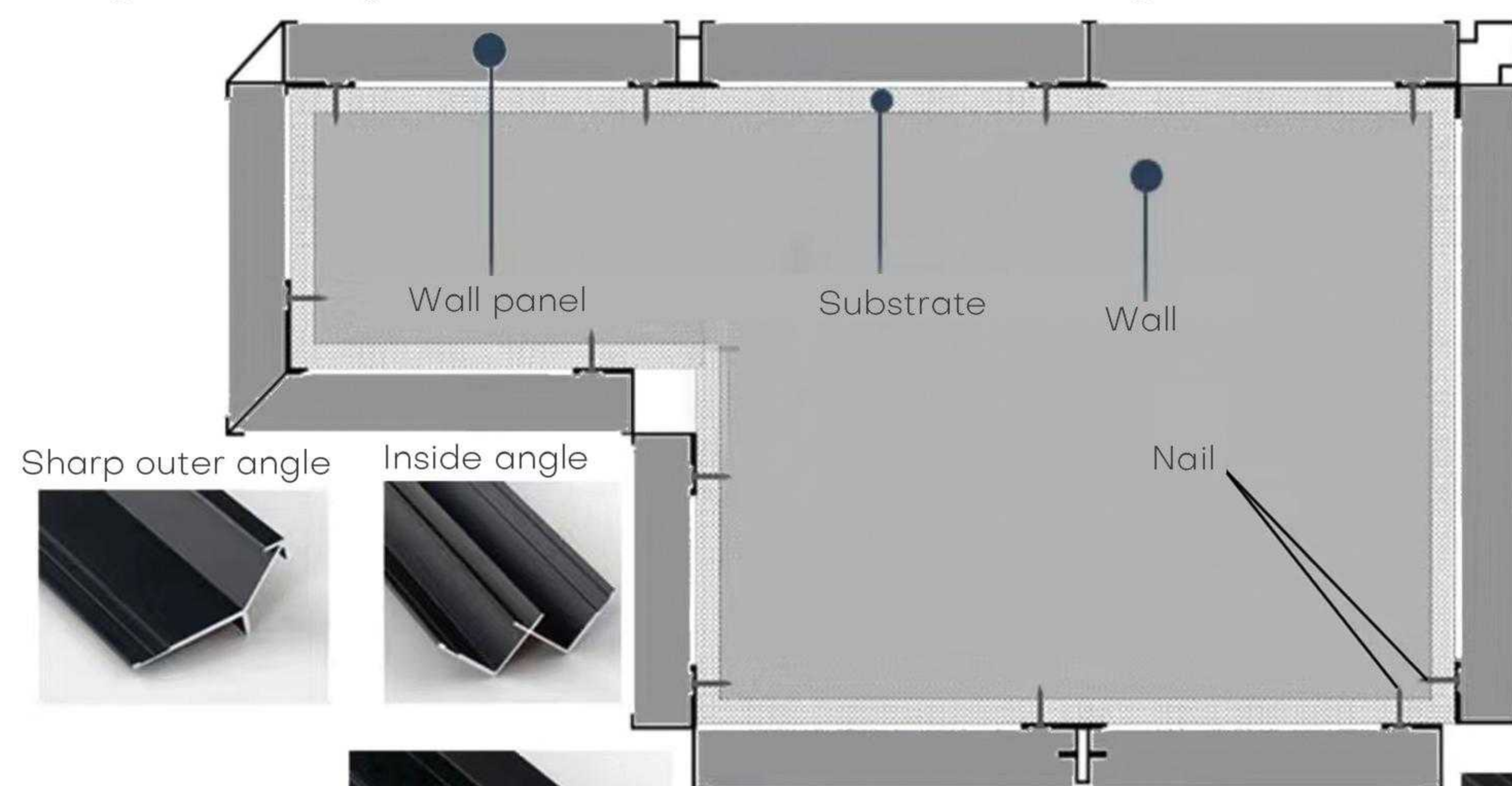

Square outer angle-1 Lumbar line-2 Side line

Installation



Step 1: Cut the WPC foam board to size. Step 2: Apply no-nail free glue to the back. Step 3: Install on the wall. Step 4: Insert the dovetail strips.

05 PVC Marble Sheet

Hot-selling product series

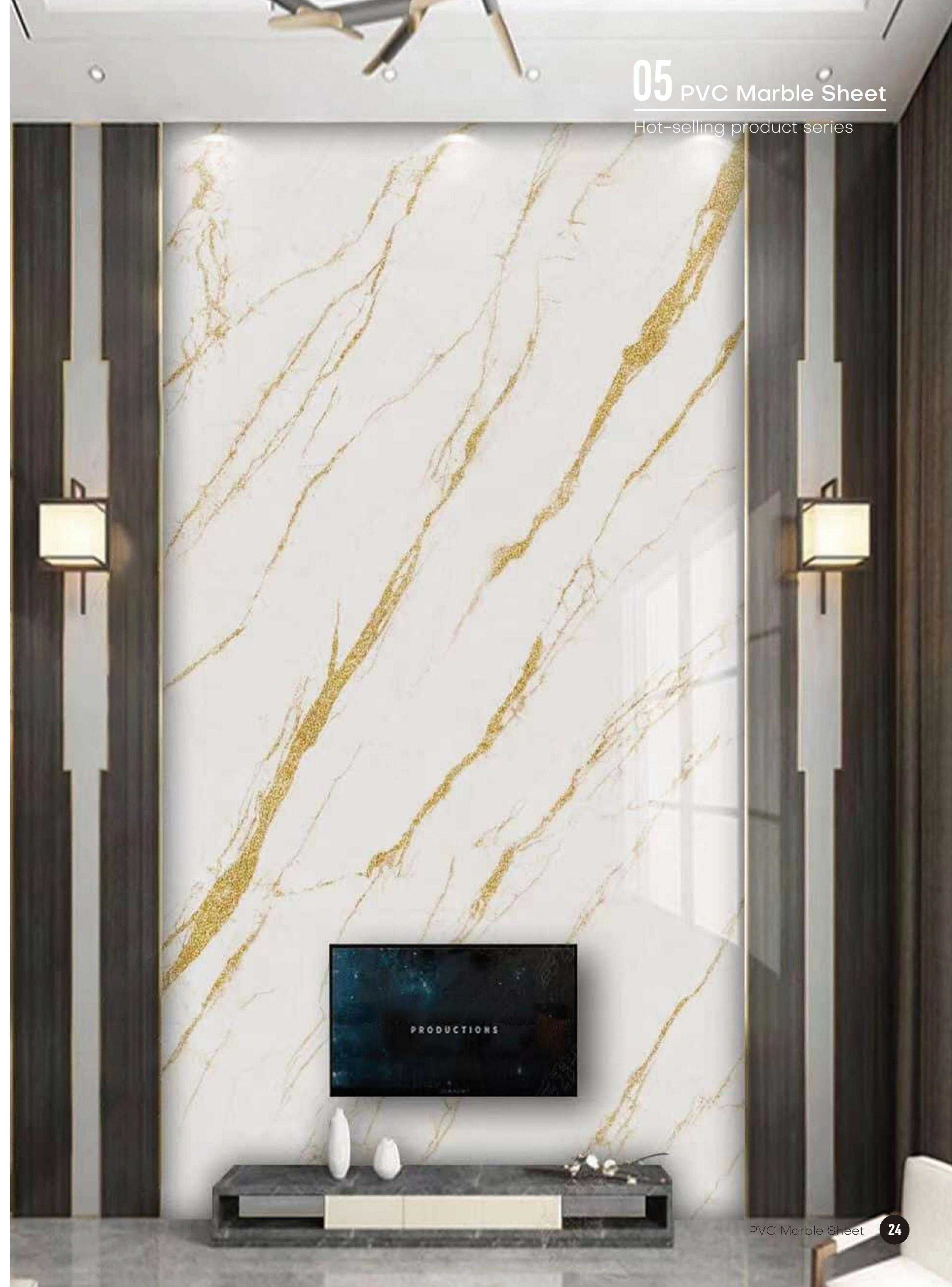

05 PVC Marble Sheet

Hot-selling product series

PVC Marble Sheet is an advanced decorative material, also known as UV coating board. It is made of high-density fiberboard or medium-density fiberboard as the base material and processed by a UV coating process. UV board has the advantages of wear resistance, pollution resistance, high-temperature resistance, water and moisture resistance, etc., and also has good surface gloss and tactile feel. It is widely used in furniture, cabinets, wardrobes, office furniture, and other fields, providing high-quality choices for interior decoration. The colors of UV boards are rich and diverse, which can meet the decoration requirements of different styles and needs.

| | |
|-----------|-----------------------------------|
| Material | Polyvinyl Chloride/Calcium Powder |
| Thickness | 2.5/2.8/3mm |
| Size | 1220*2440/2800/2900mm |
| Surface | Hot Stamp/PVC Film/3D Printing |

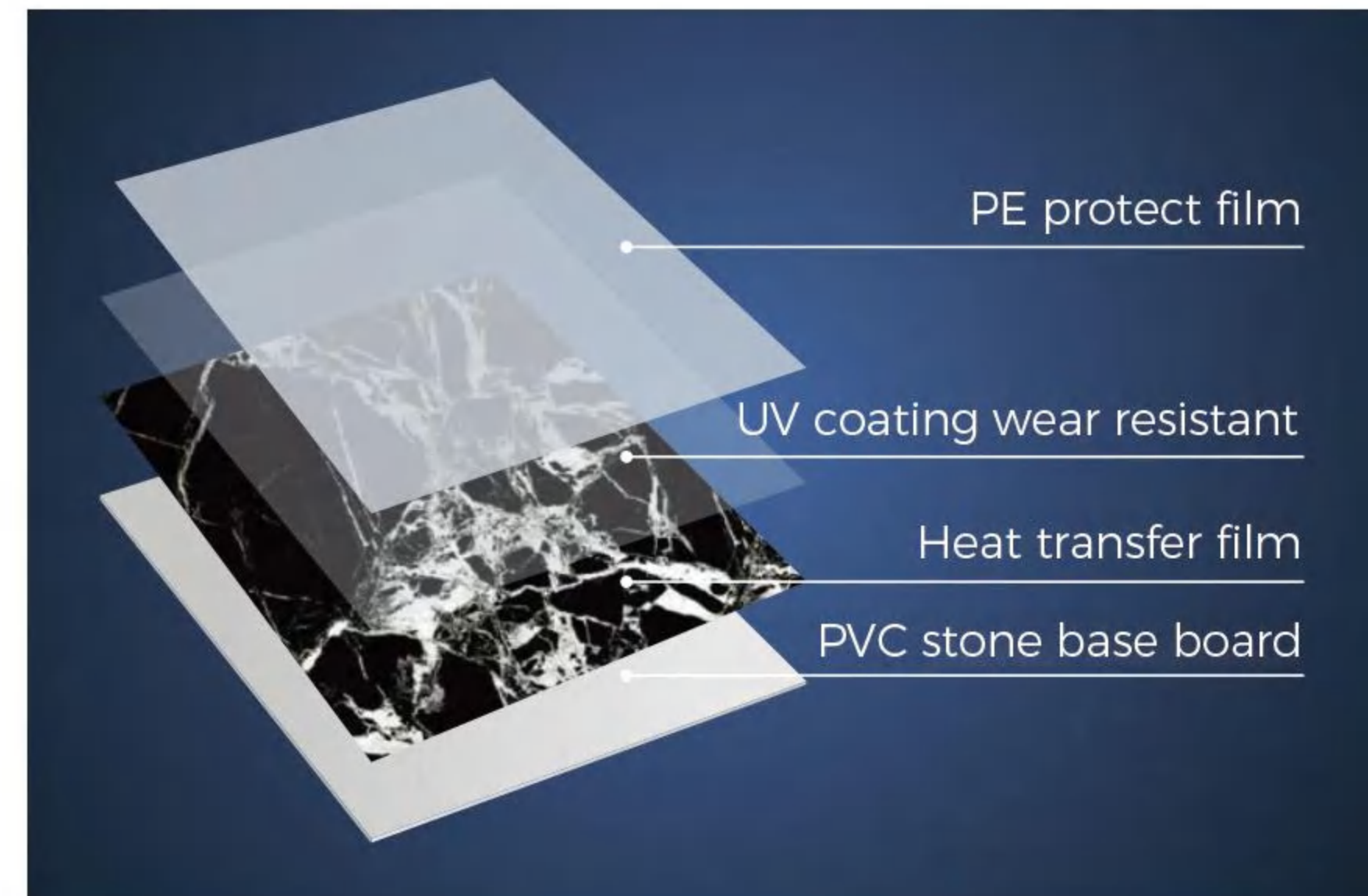

PVC Film

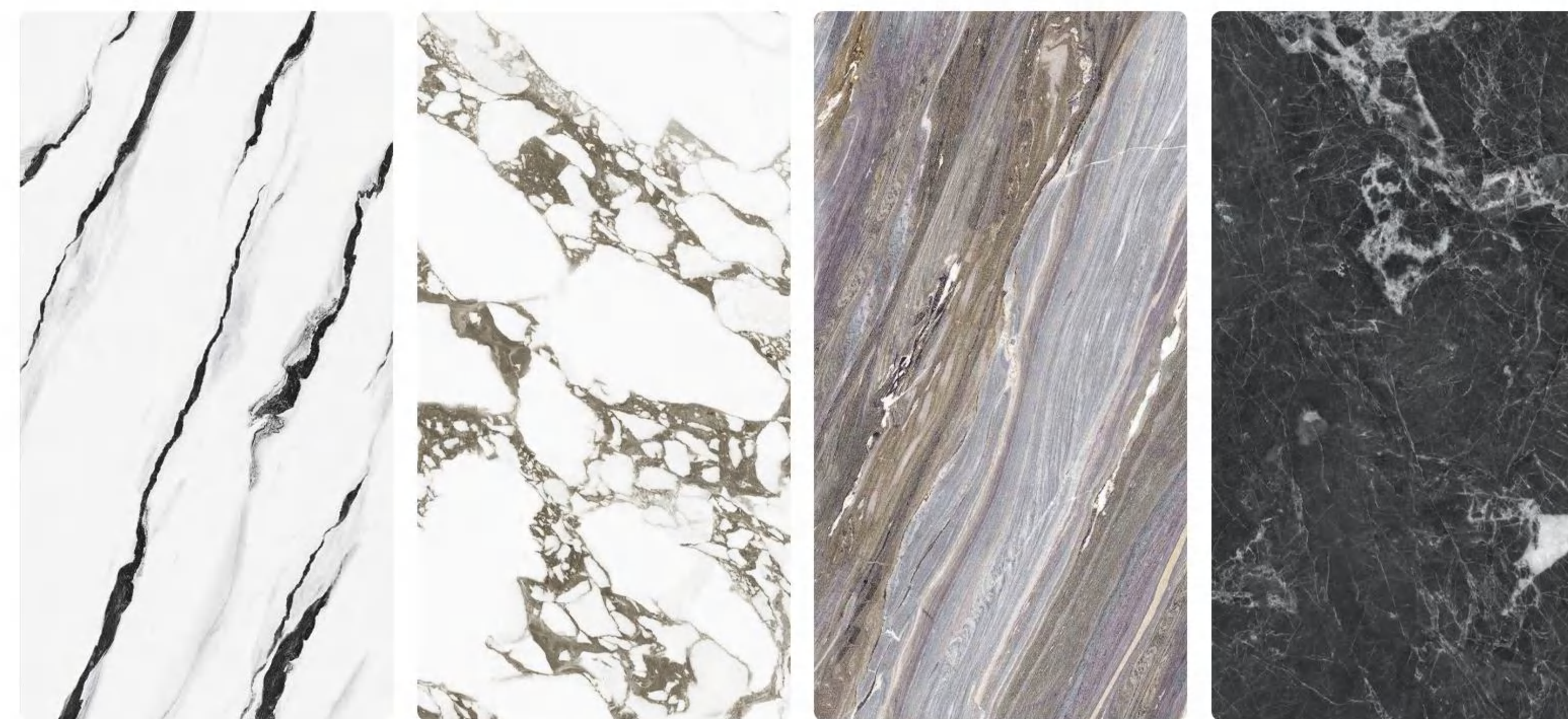

P-001 P-002 P-003 P-004

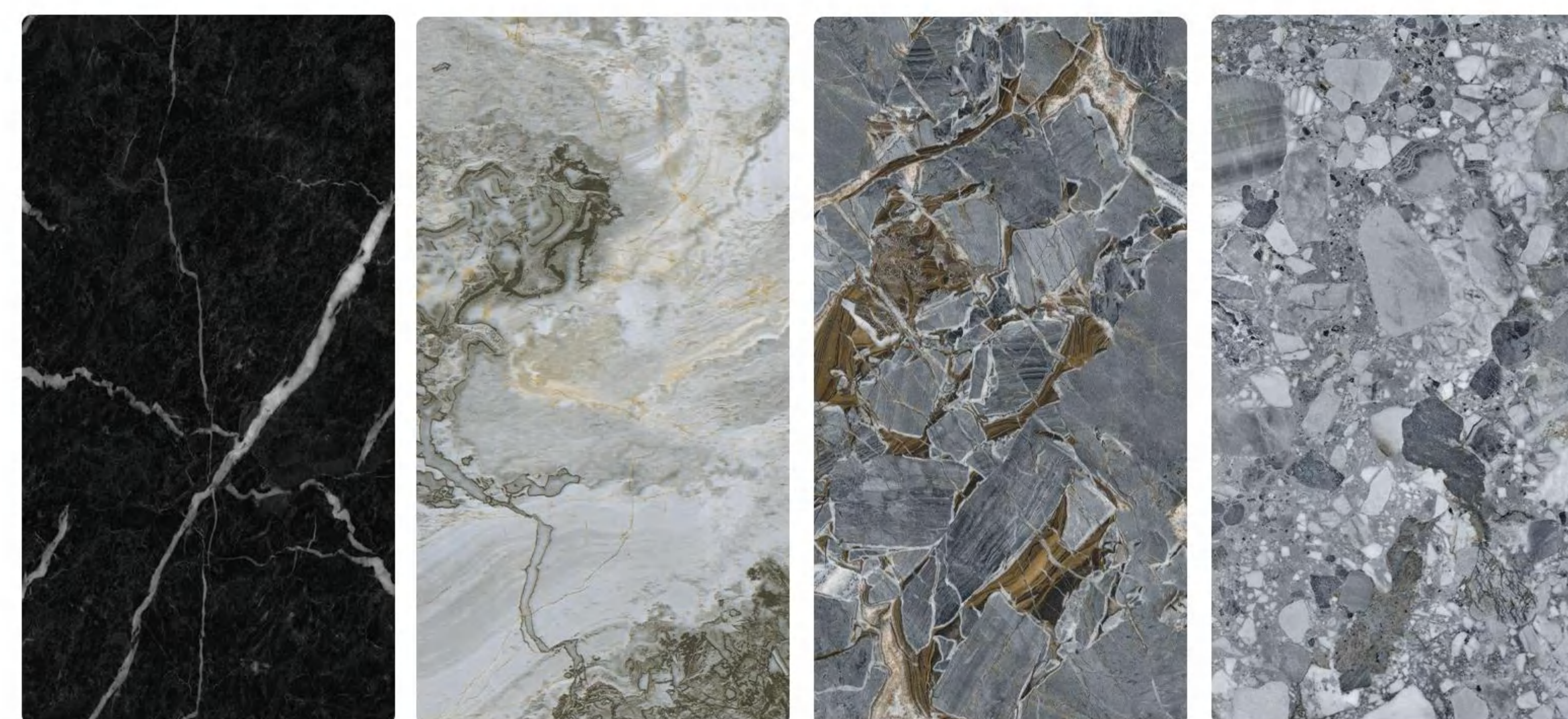

P-005 P-006 P-007 P-008



P-009 P-010

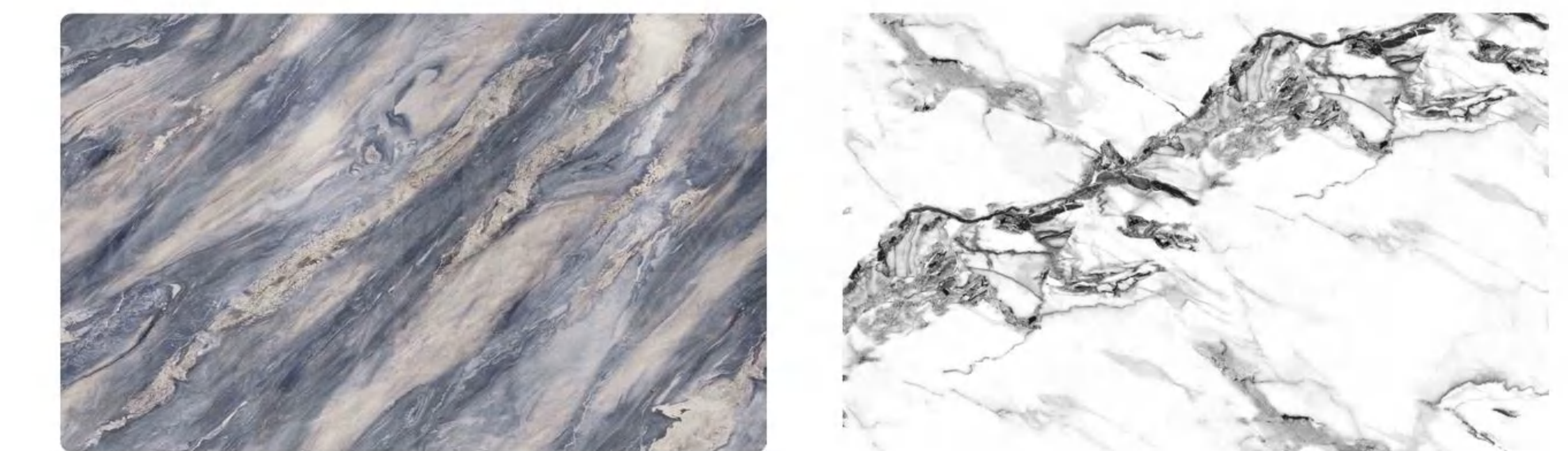

P-011 P-012

05 PVC Marble Sheet

Hot-selling product series

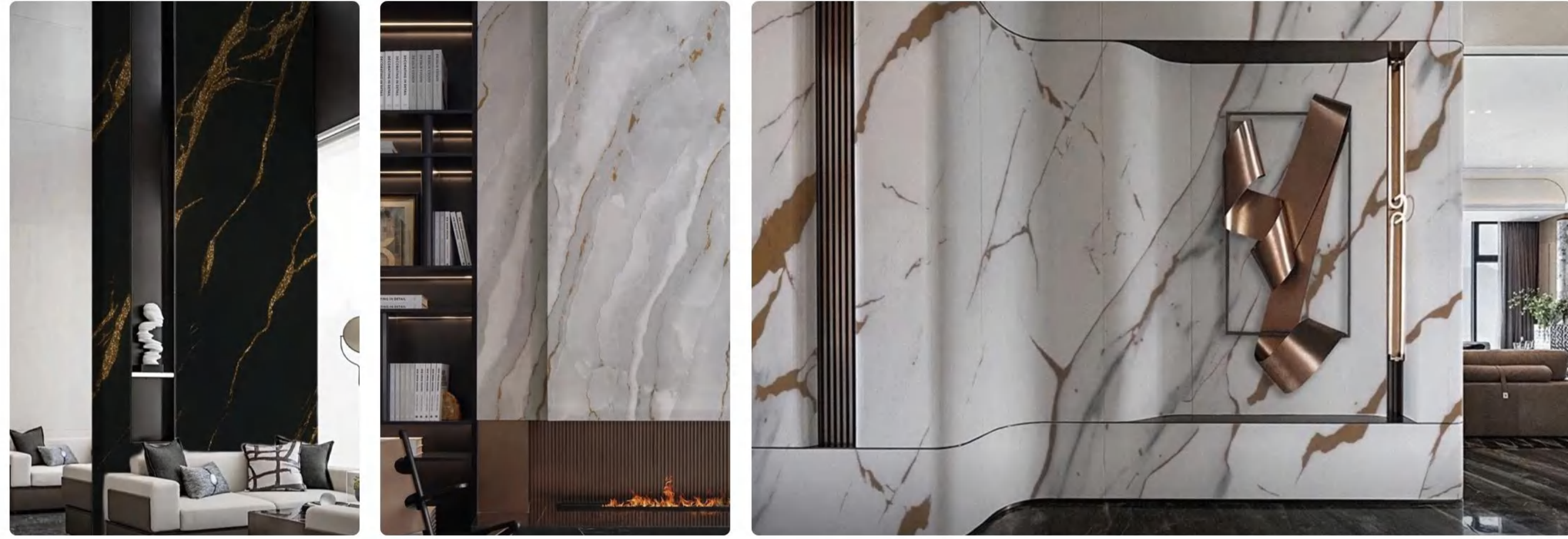

Gilded Marble Sheet

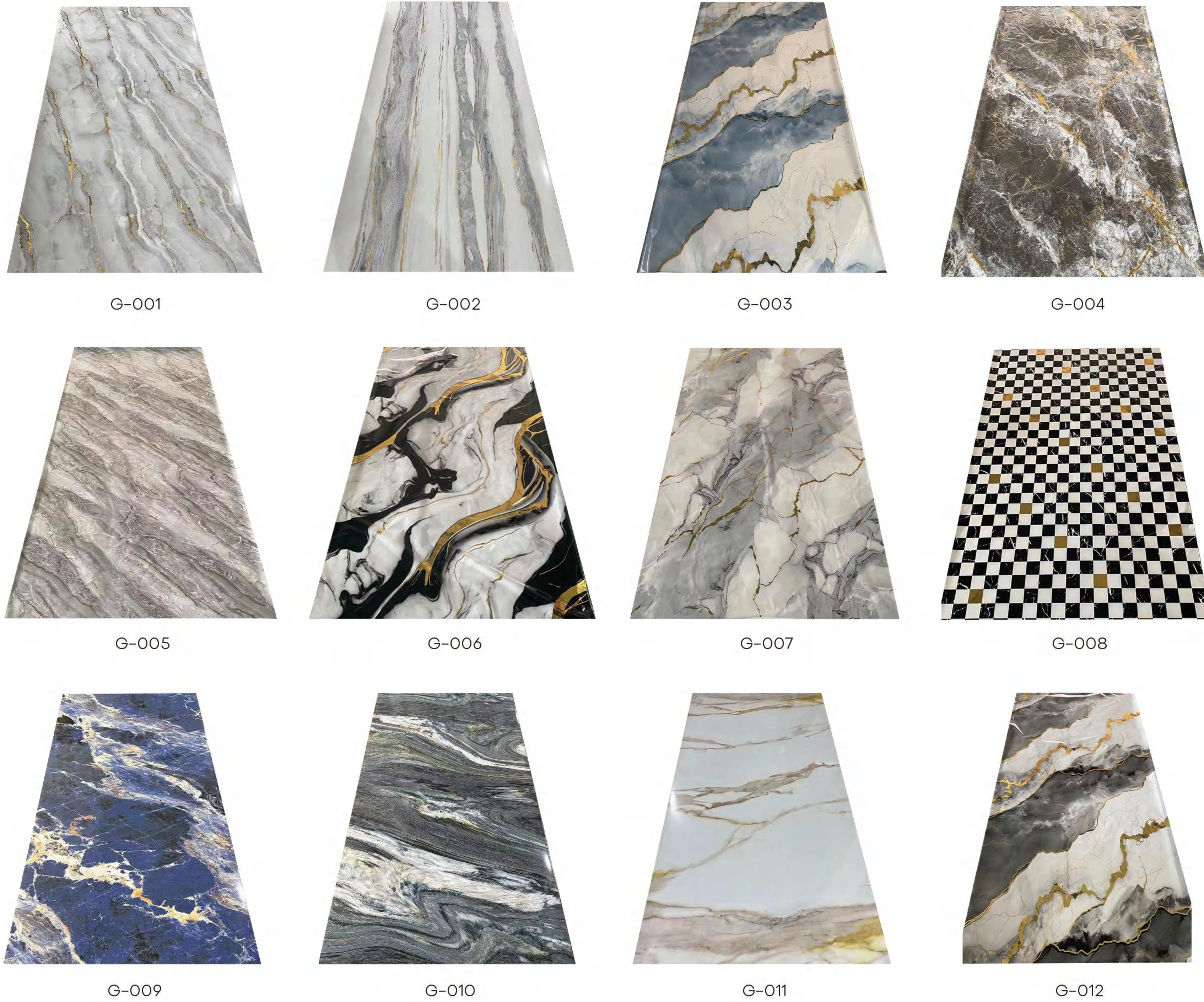

3D Print(Open Book)

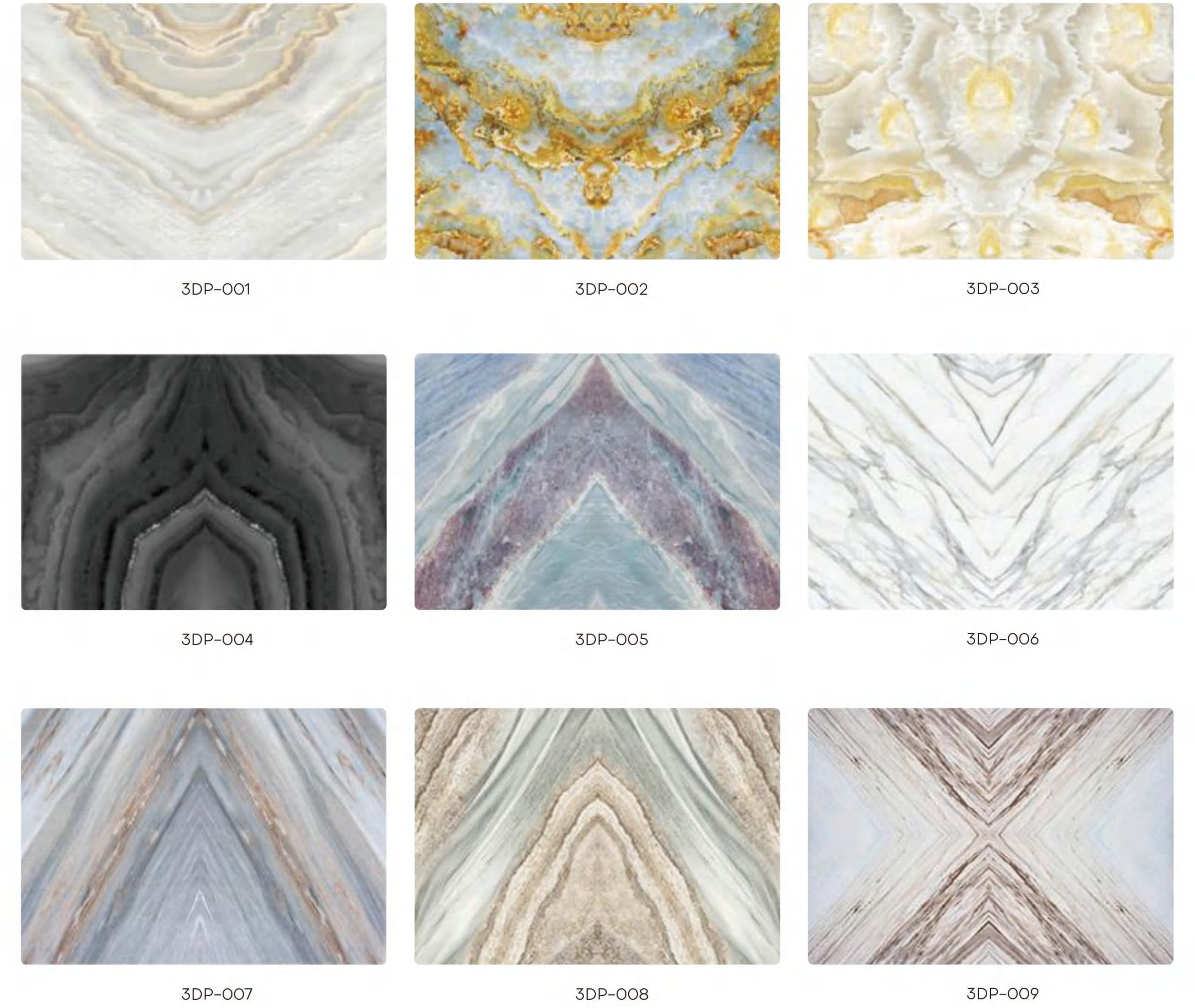

05 PVC Marble Sheet

Hot-selling product series

Heat Transfer Printing



H-001



H-002

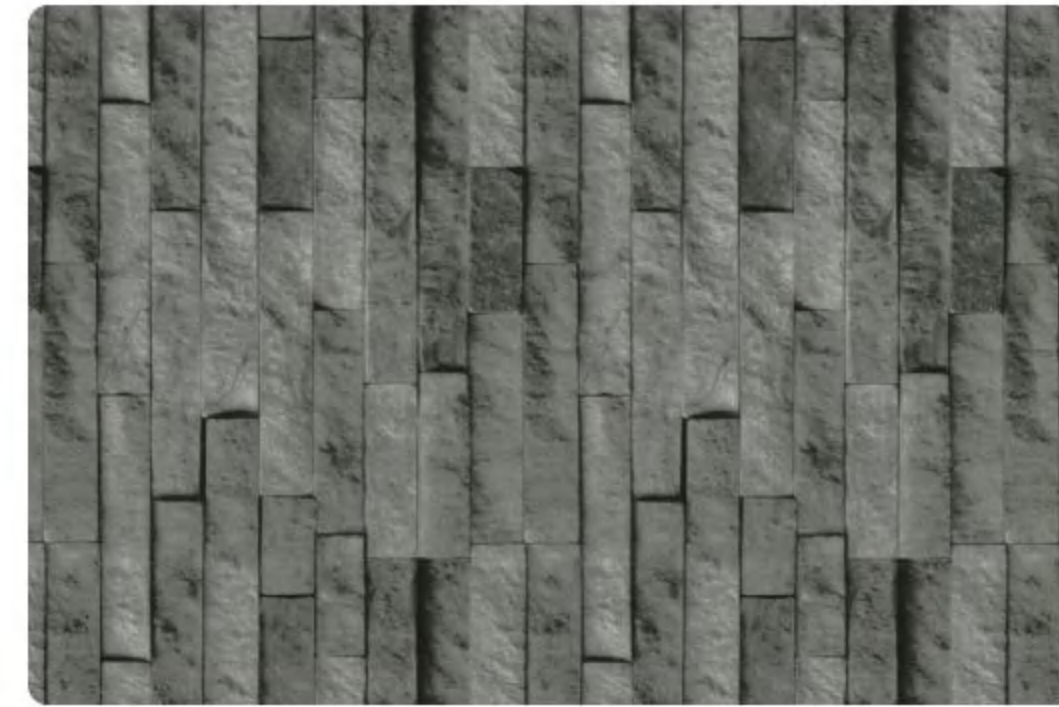

H-003

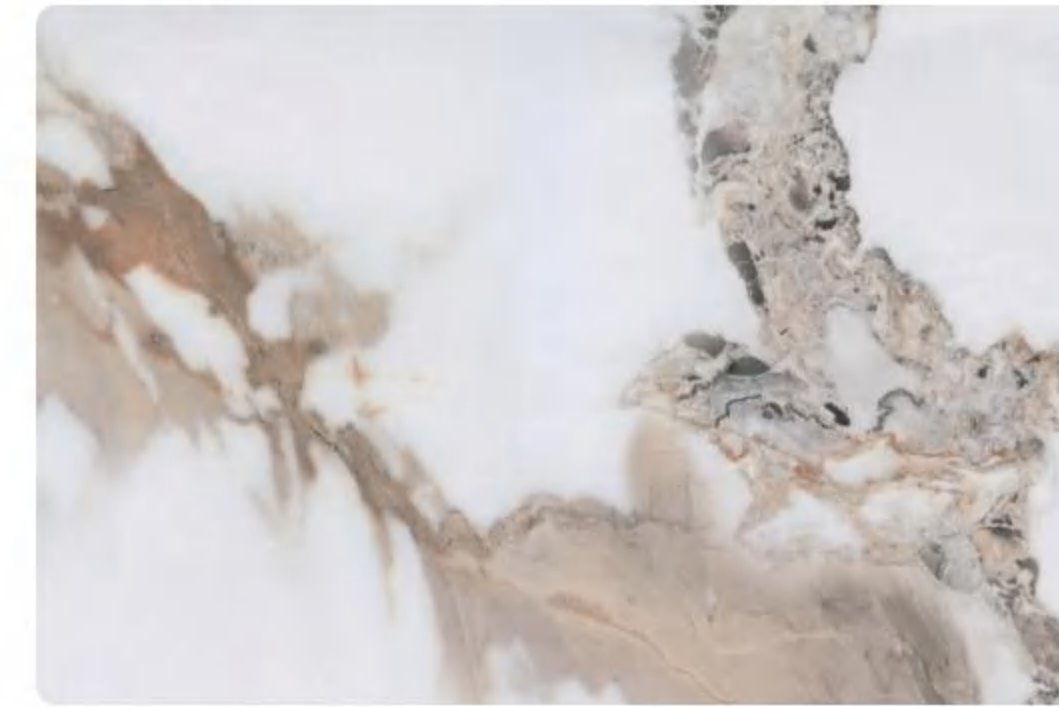

H-004



H-005



H-006



H-007



H-008



H-009



H-010



H-011



H-012



3D



3D-001

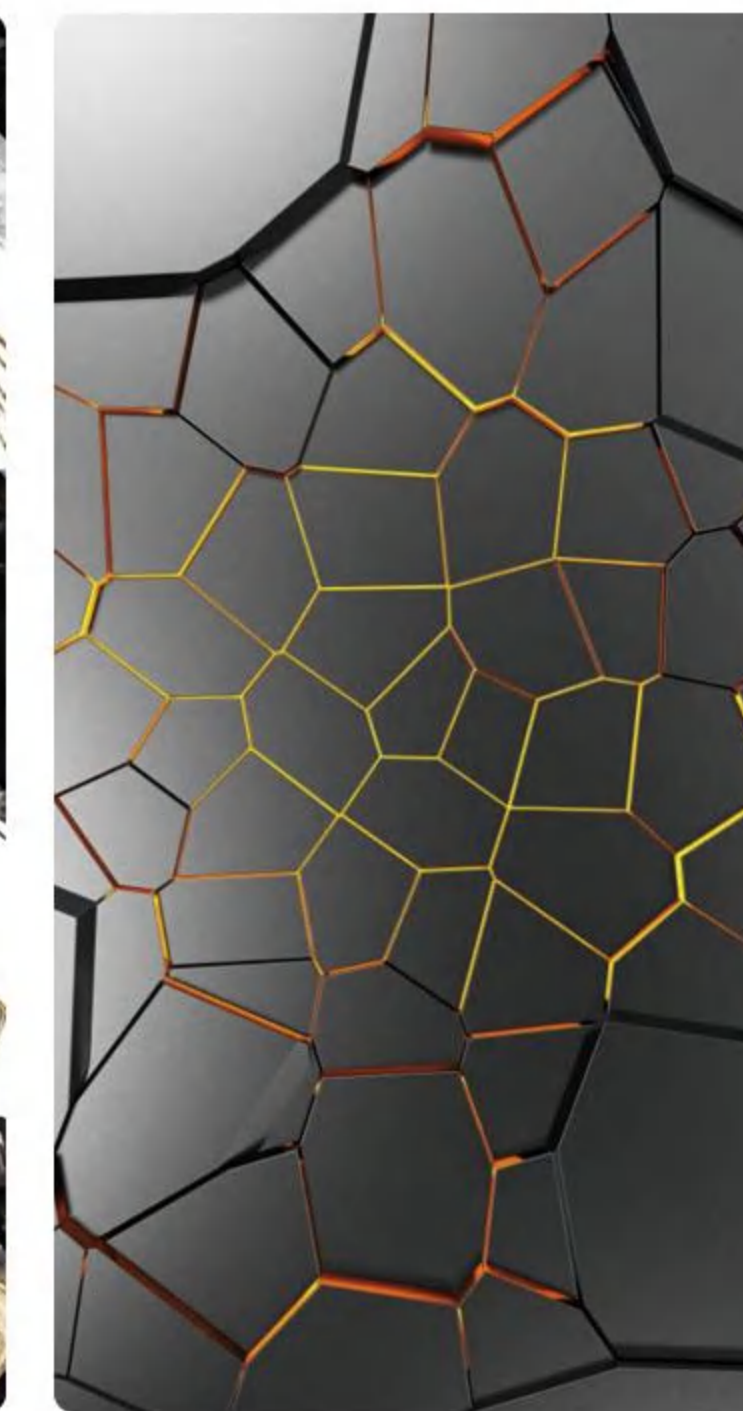

3D-002



3D-003

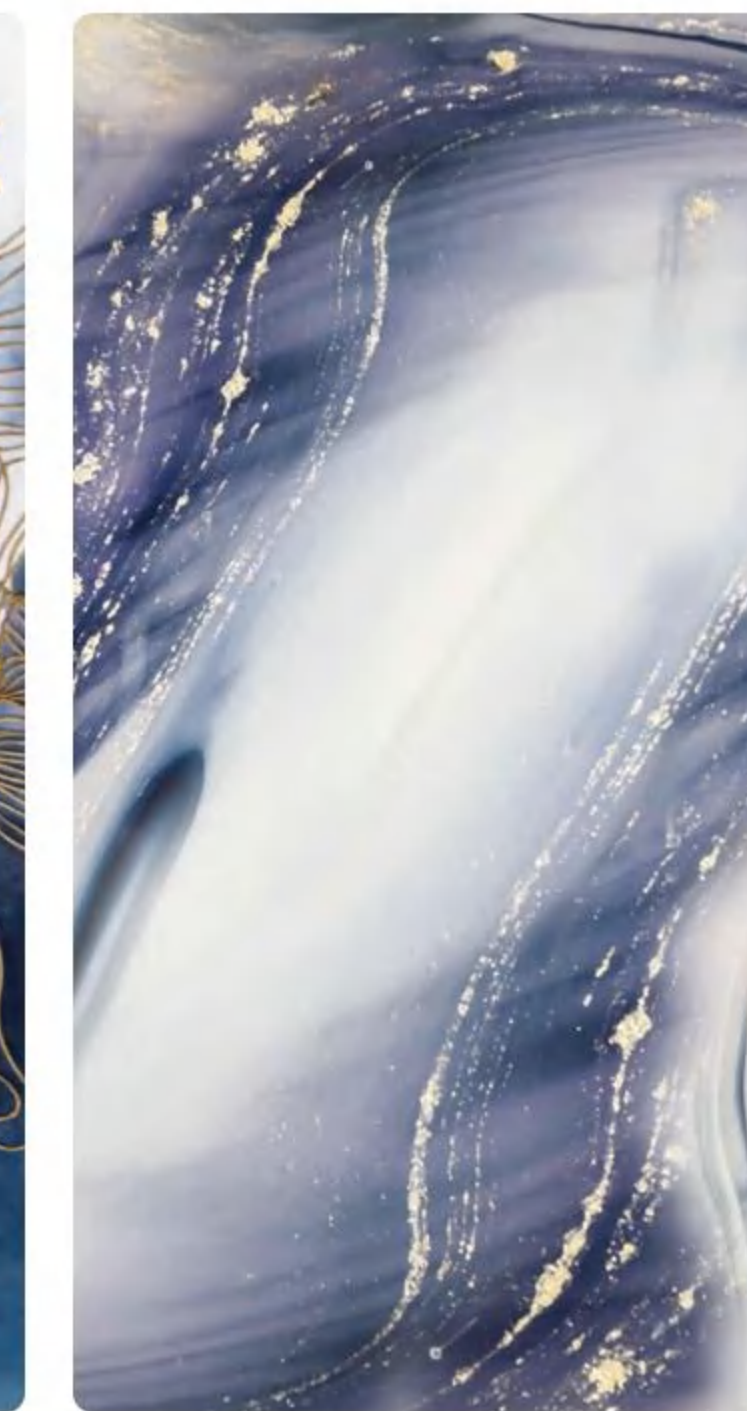

3D-004

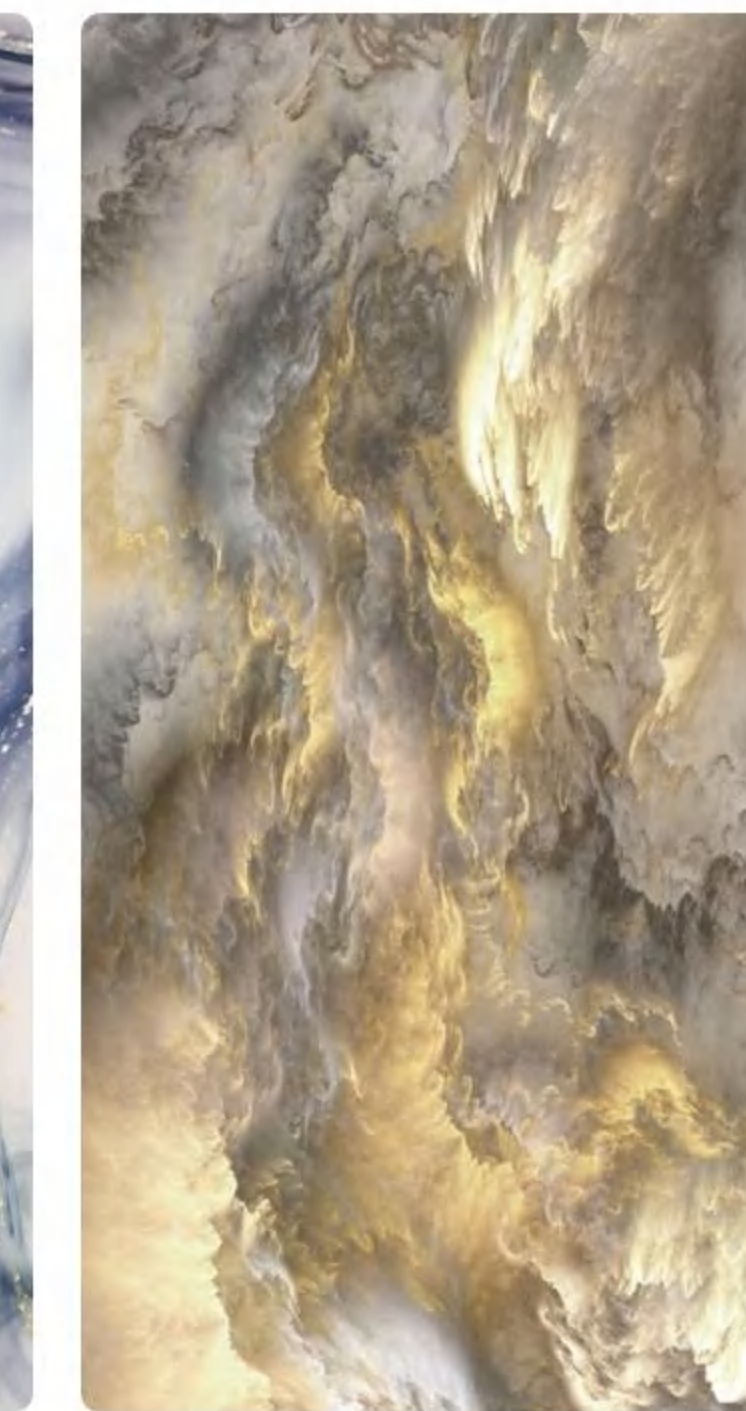

3D-005



3D-006



3D-007

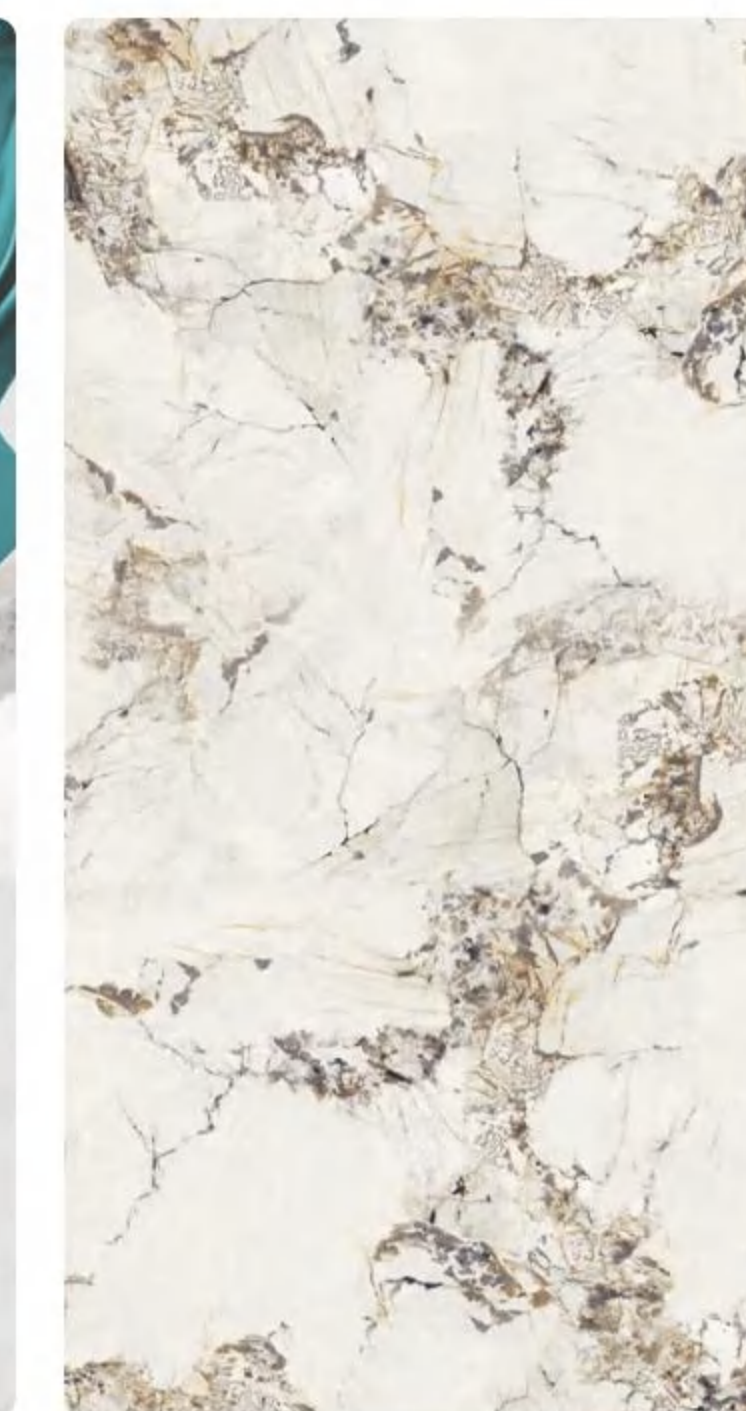

3D-008



3D-009



3D-010

05 PVC Marble Sheet

Installation Method



Step 1

Measure the required dimensions.



Step 2

Cut the UV wall panel with a utility knife.



Step 3

Apply nail free glue to the back.



Step 4

Paste it on the wall.

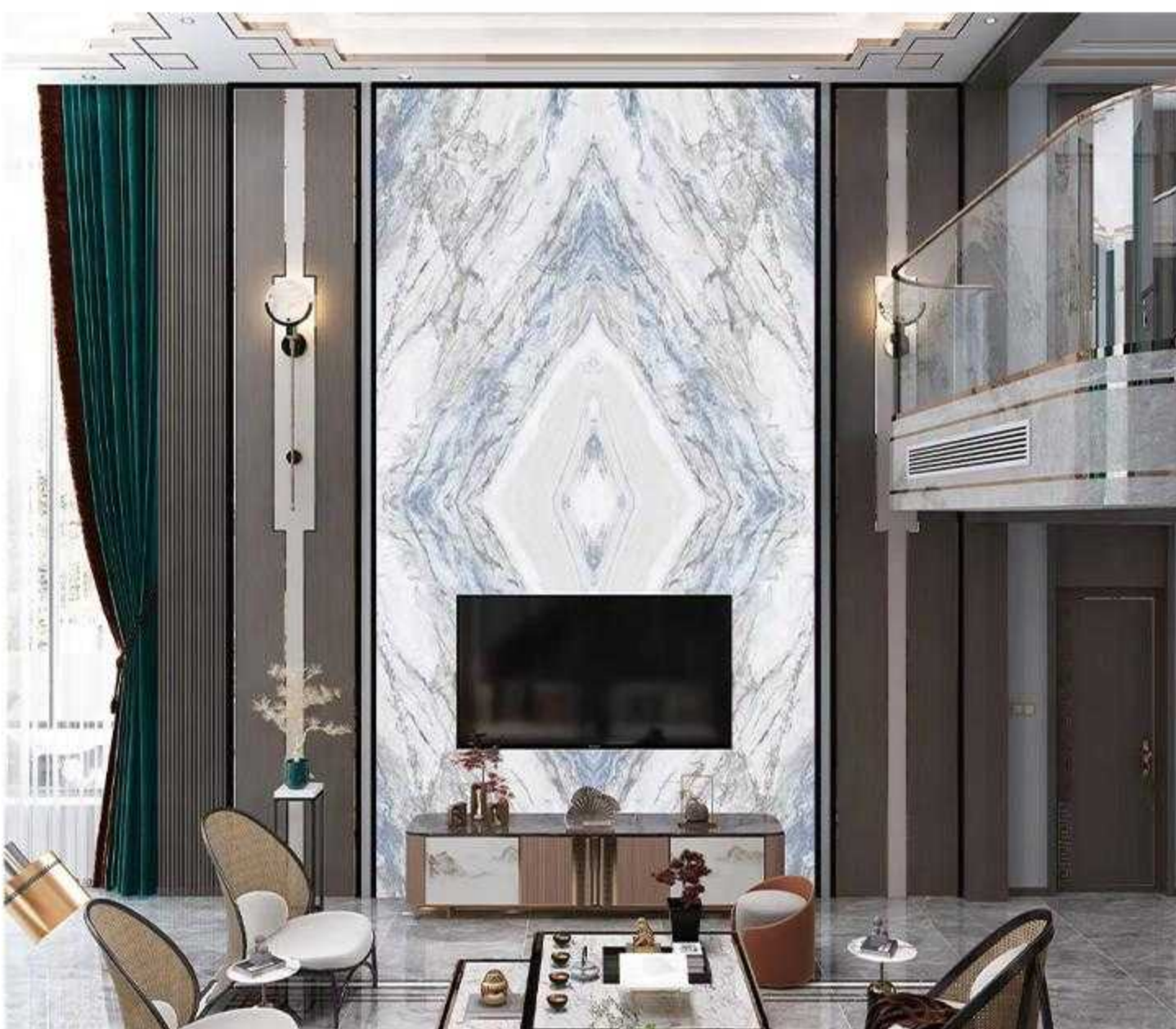

06 PS Wall Panel

Hot-selling product series

PS wall panels are made from polystyrene (PS) and have low density, making them lightweight with good sound and thermal insulation. Widely used in construction and decoration, they are easy to install, durable, and have good seismic resistance. Additionally, they can be customized with paint or wallpaper for personalized decorative effects.

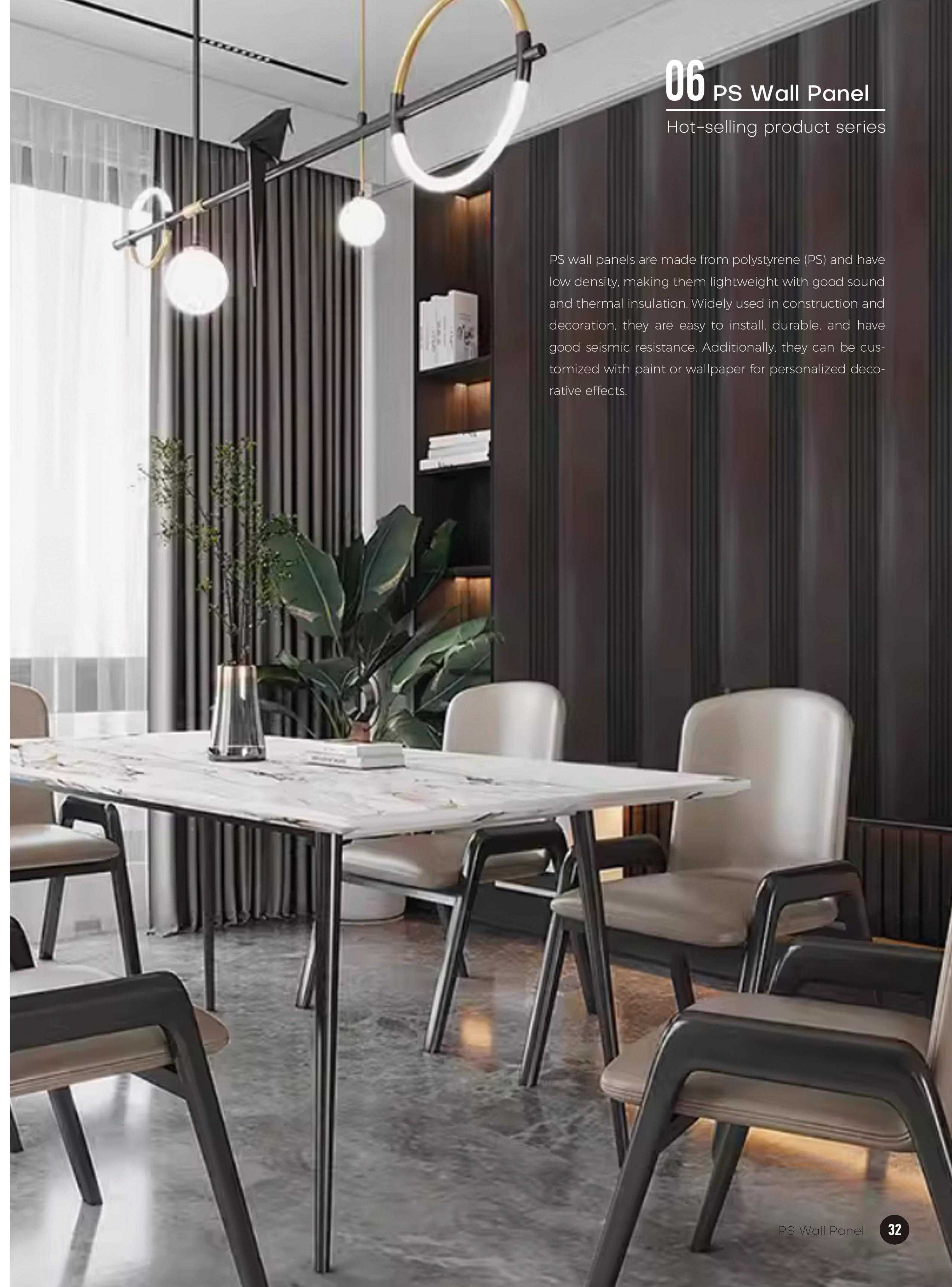

06 PS Wall Panel

Hot-selling product series

CSW M01
 W 160mm
 H 14mm
 L 2900mm

CSW M09
 W 150mm
 H 12mm
 L 2900mm

CSW M02
 W 120mm
 H 12mm
 L 2900mm

CSW M10
 W 160mm
 H 12mm
 L 2900mm

CSW M03
 W 120mm
 H 12mm
 L 2900mm

CSW M11
 W 120mm
 H 12mm
 L 2900mm

CSW M04
 W 150mm
 H 10mm
 L 2900mm

CSW M12
 W 120mm
 H 12mm
 L 2900mm

CSW M05
 W 120mm
 H 10mm
 L 2900mm

CSW M13
 W 120mm
 H 11.2mm
 L 2900mm

CSW M06
 W 120mm
 H 20mm
 L 2900mm

CSW M14
 W 120mm
 H 12mm
 L 2900mm

CSW M07
 W 120mm
 H 12mm
 L 2900mm

CSW M15
 W 120mm
 H 12mm
 L 2900mm

CSW M08
 W 160mm
 H 12mm
 L 2900mm

CSW M16
 W 160mm
 H 20mm
 L 2900mm



CSW S01
 W 300mm
 H 7mm
 L 2900mm

CSW S02
 W 300mm
 H 7mm
 L 2900mm

CSW S03
 W 300mm
 H 7mm
 L 2900mm

CSW S04
 W 300mm
 H 7mm
 L 2900mm

CSW S05
 W 300mm
 H 7mm
 L 2900mm

CSW S06
 W 300mm
 H 7mm
 L 2900mm

CSW S07
 W 300mm
 H 8mm
 L 2900mm

06 PS Wall Panel

Installation Method

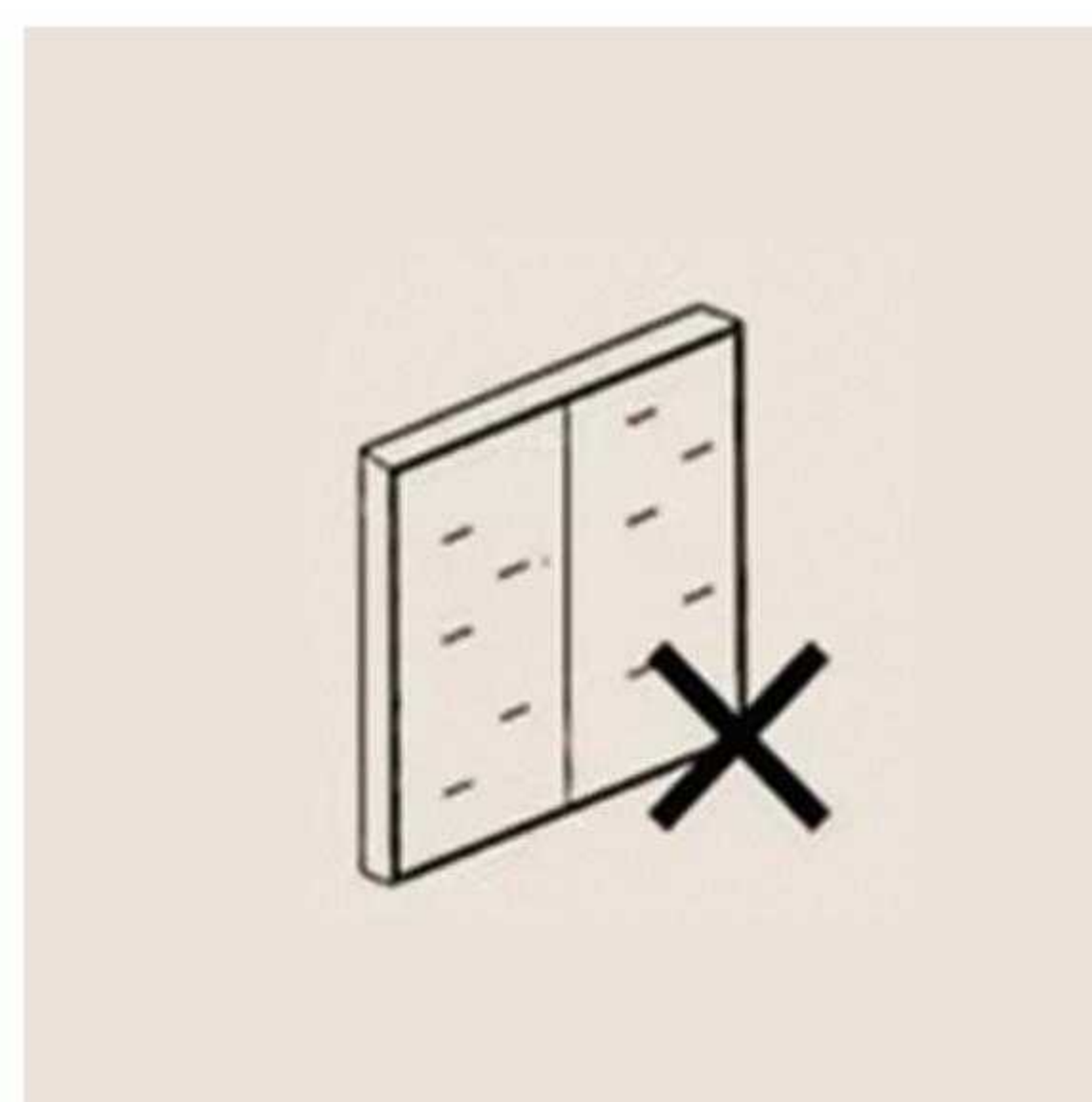

• **Step 1**
Clean the wall surface thoroughly and ensure it is flat.

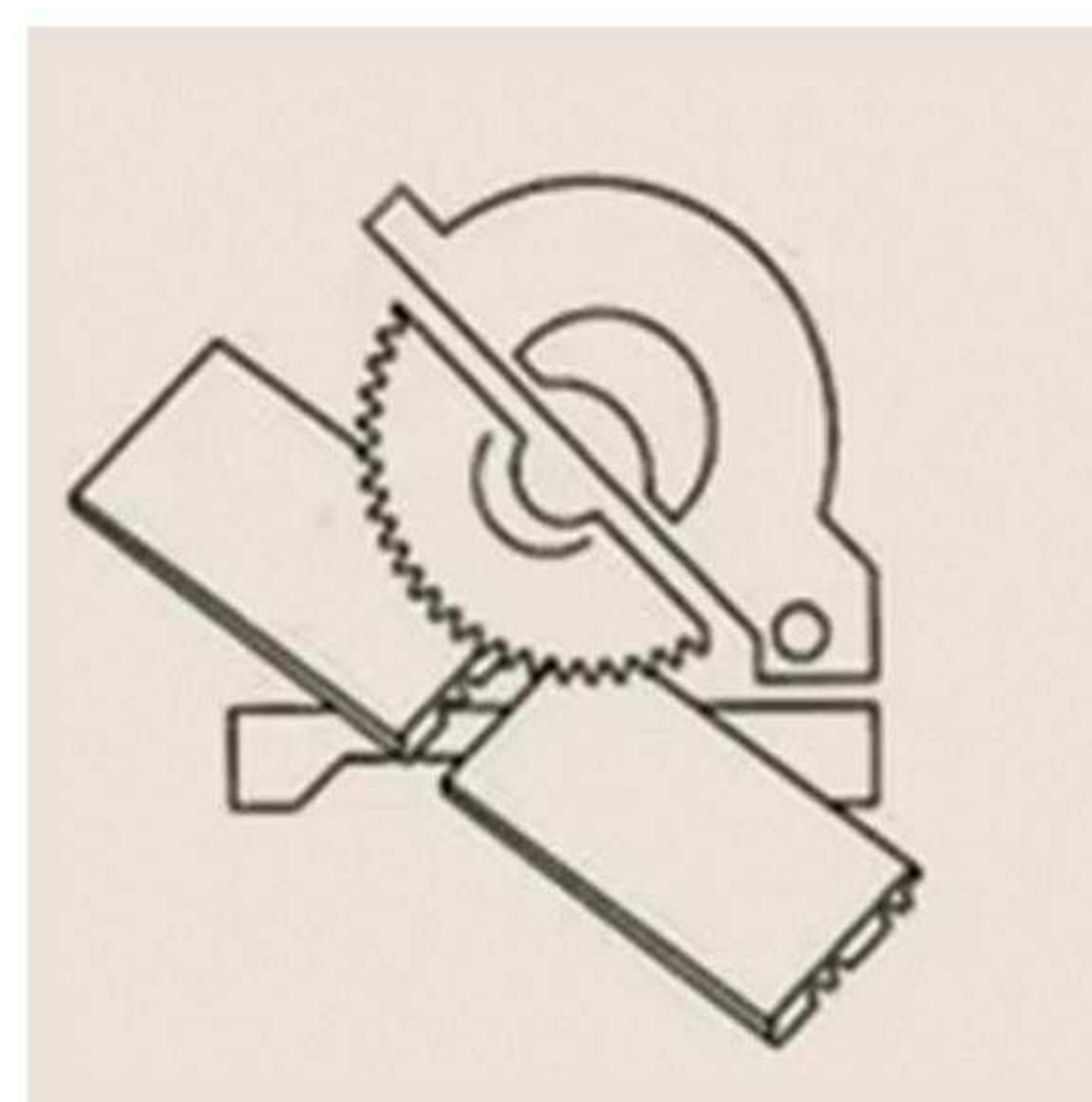

• **Step 2**
Measure and cut the panels to fit.

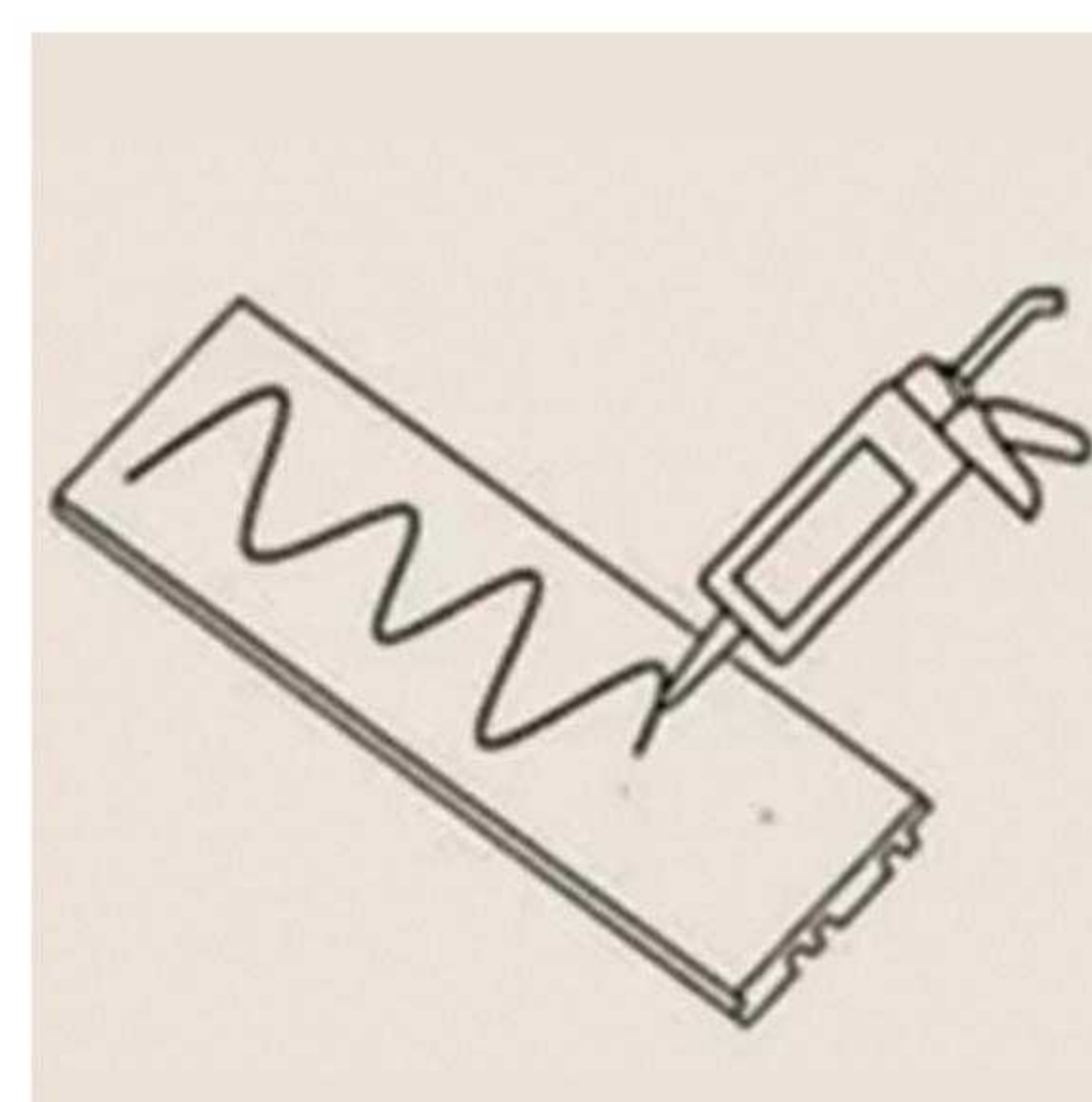

• **Step 3**
Apply nail free glue to the back.

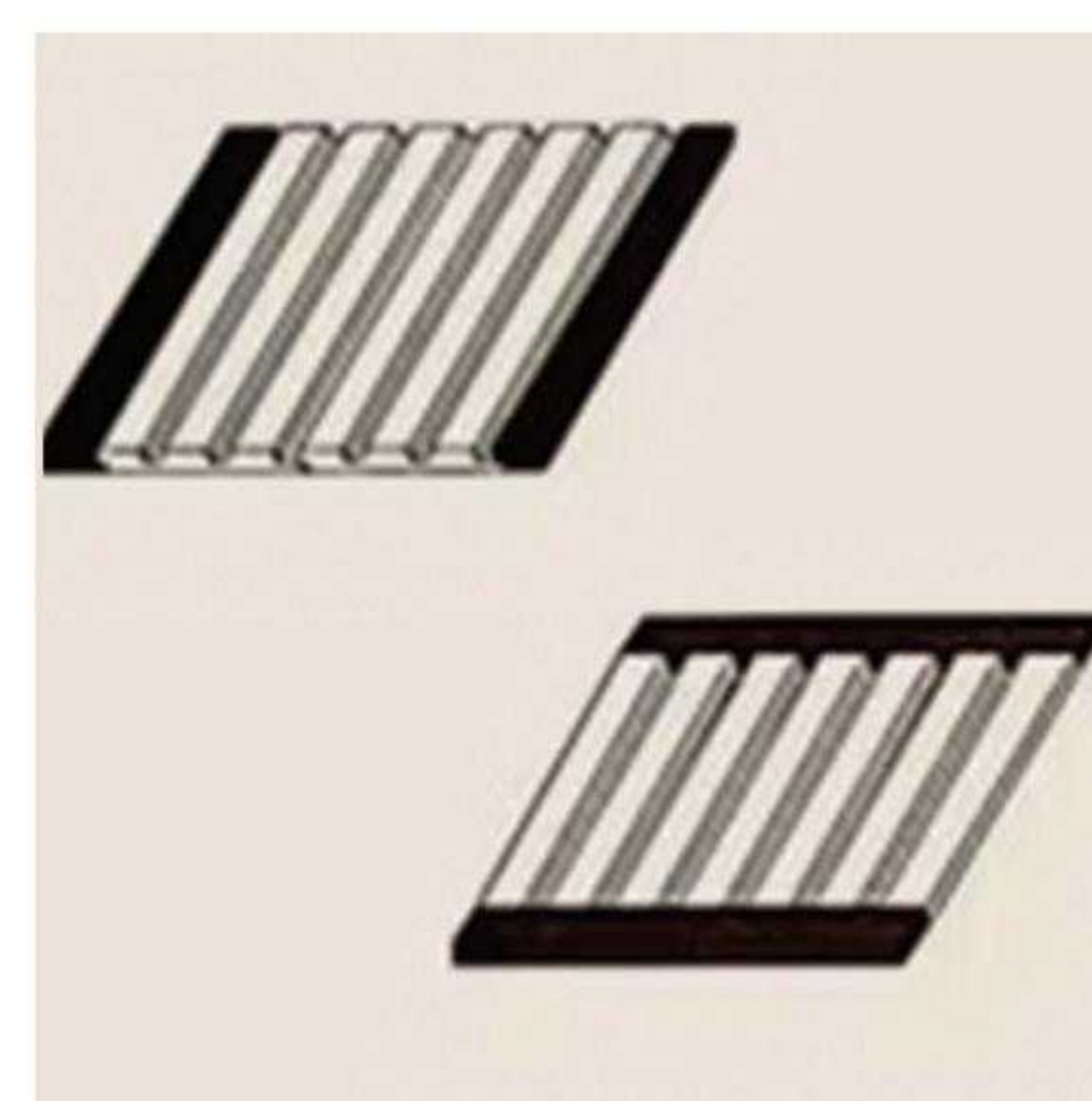

• **Step 4**
Complete the installation.

07 Slat Acoustic Panel

Hot-selling product series



07 Slat Acoustic Panel

Hot-selling product series

Slat Acoustic Panels provide an excellent look and improve acoustics by absorbing echoes and reverberations, making the room environment more pleasant. Slat Acoustic Panels can be widely used on walls and ceilings in living rooms, corridors, kitchens, children's rooms, bedrooms, and offices. They are also suitable for public spaces, shops, restaurants, and more.



Tech Veneer



Natural Veneer



Dyed/Smoked



Melamine

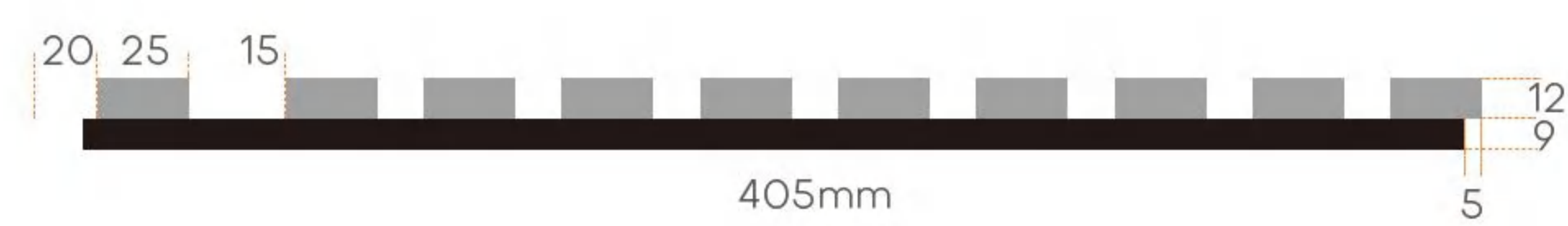
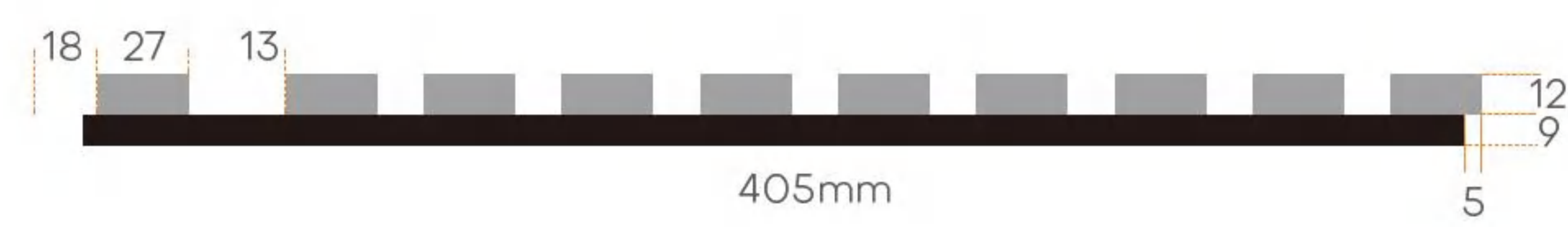
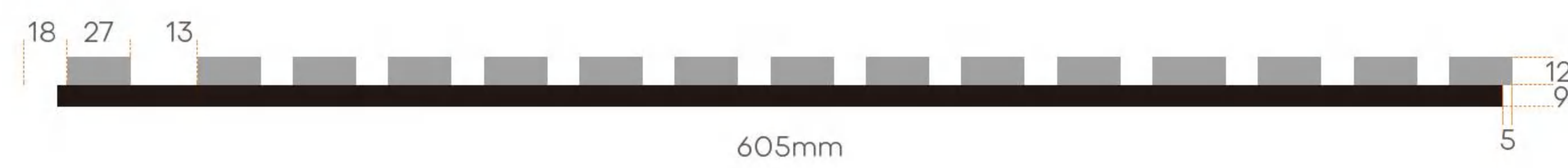

Full Panel Size: 2400~3000mm x 600/400mm x 22mm

*We have more other customized size



- Absorb the noise
- Sound insulation
- Moistureproof
- Environmental protection

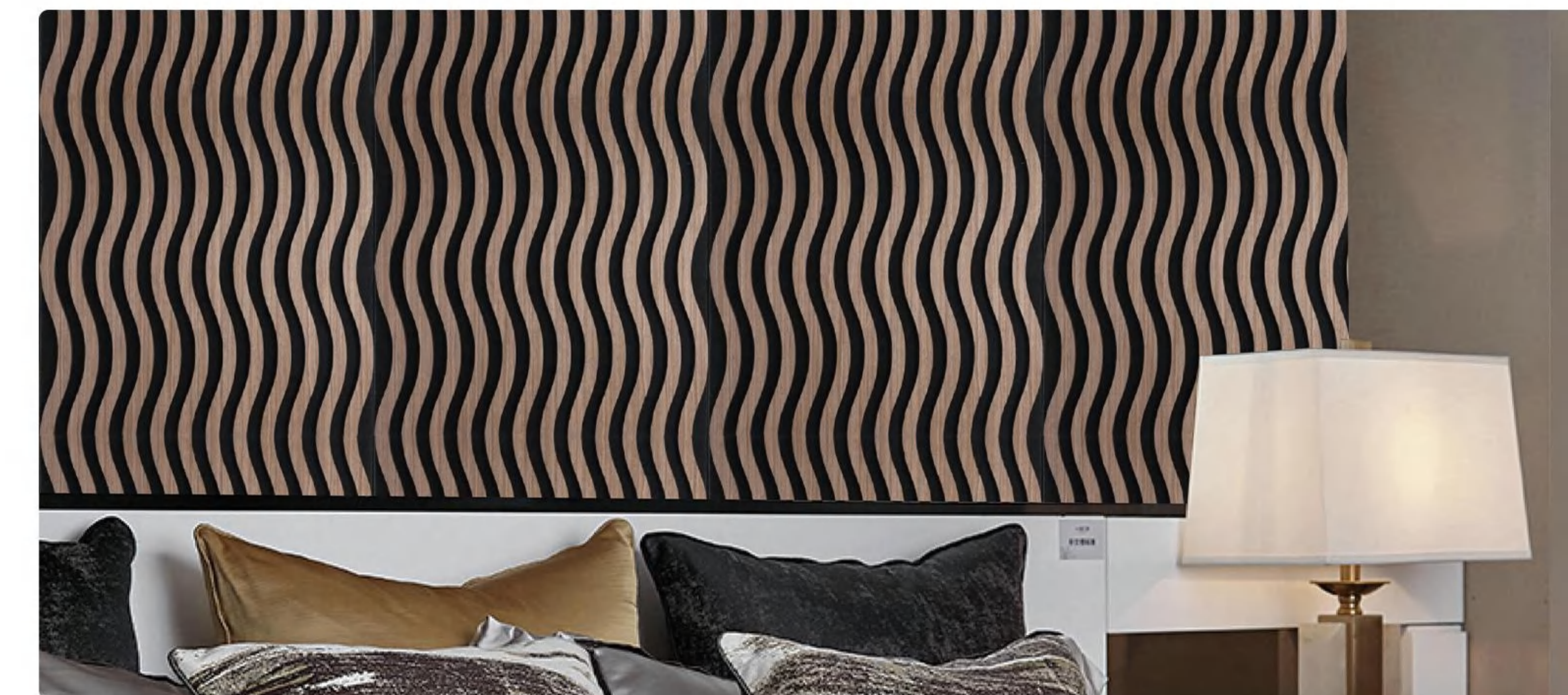
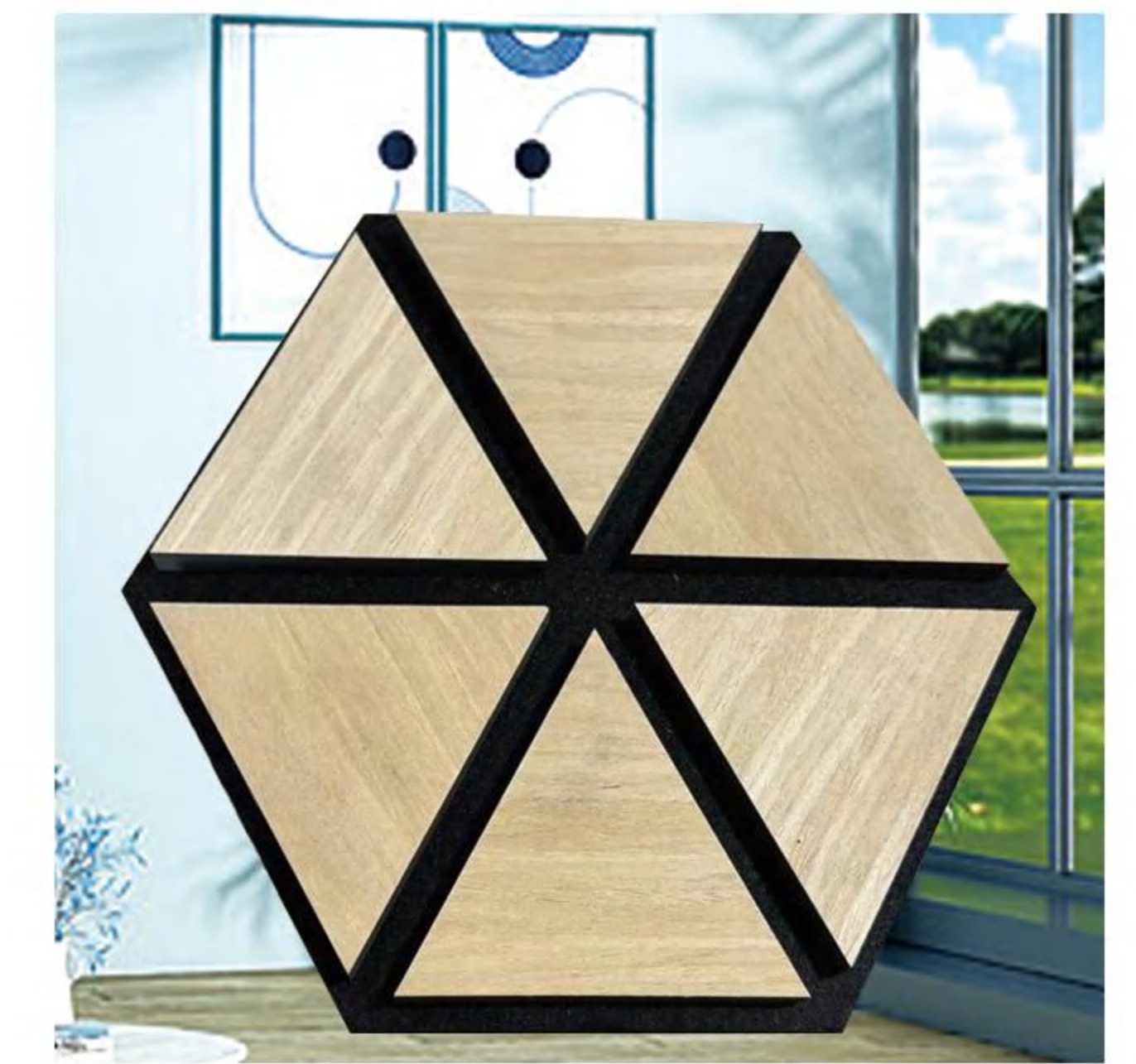
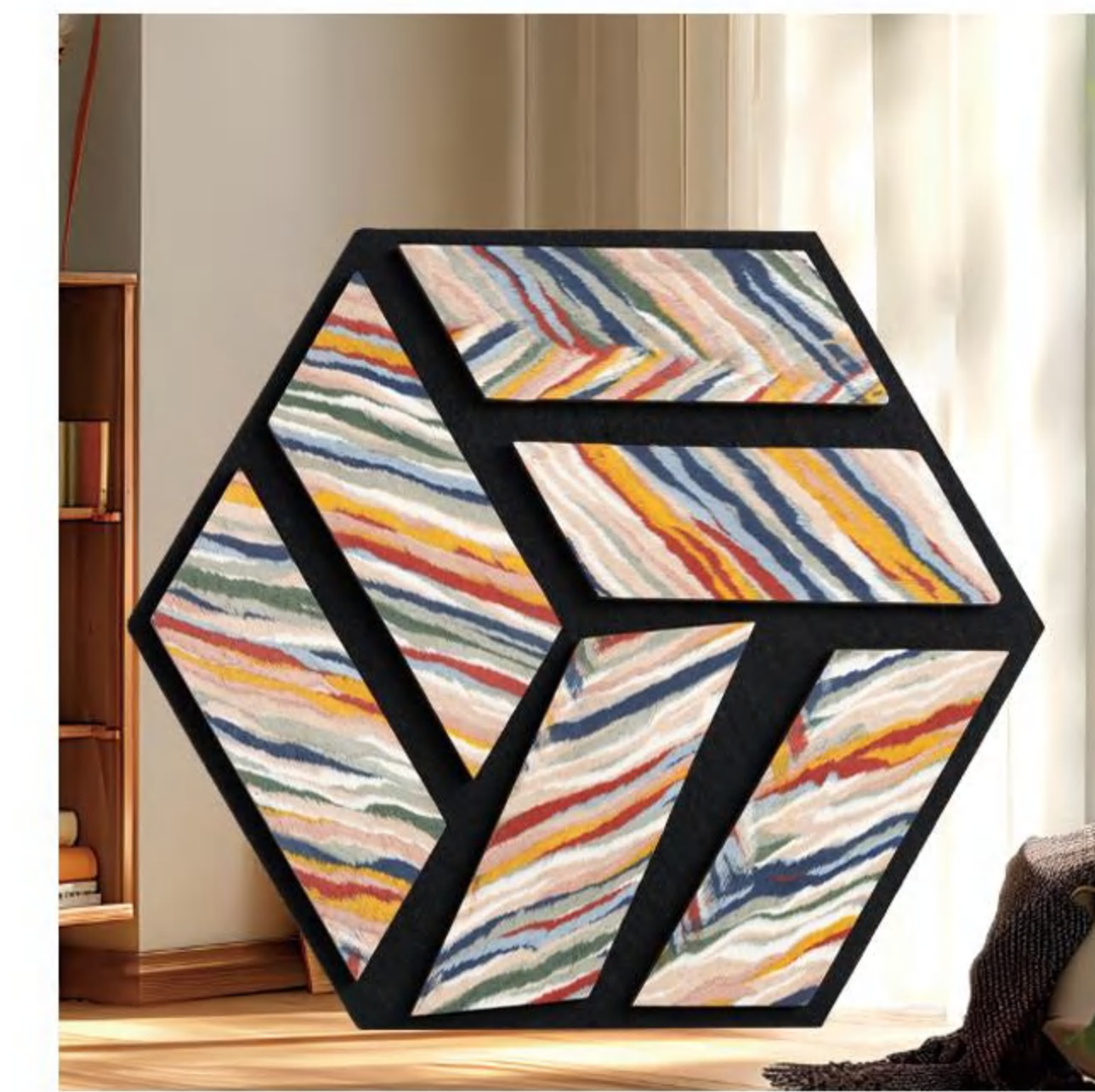
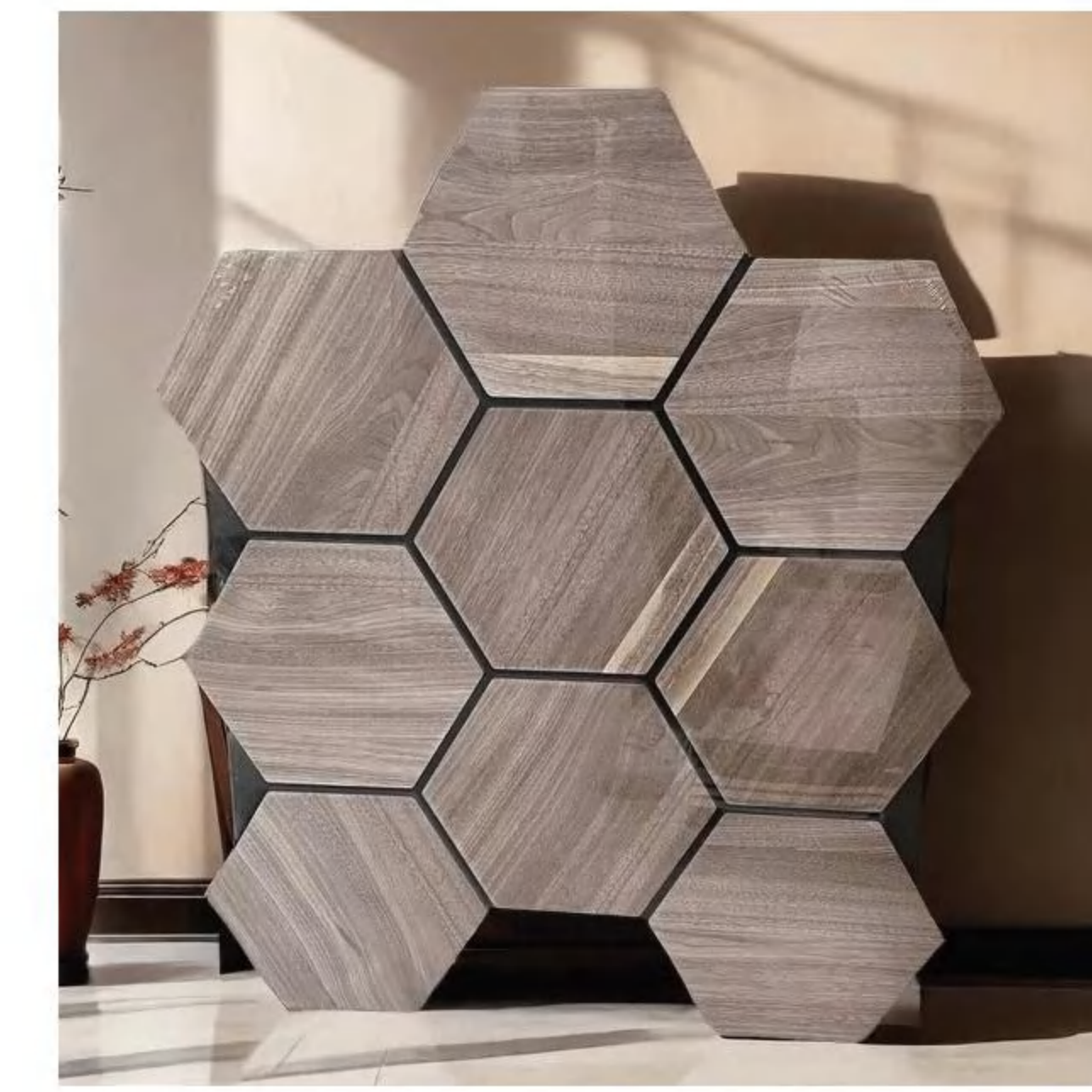

07 Slat Acoustic Panel

Installation Method

◦ Installation

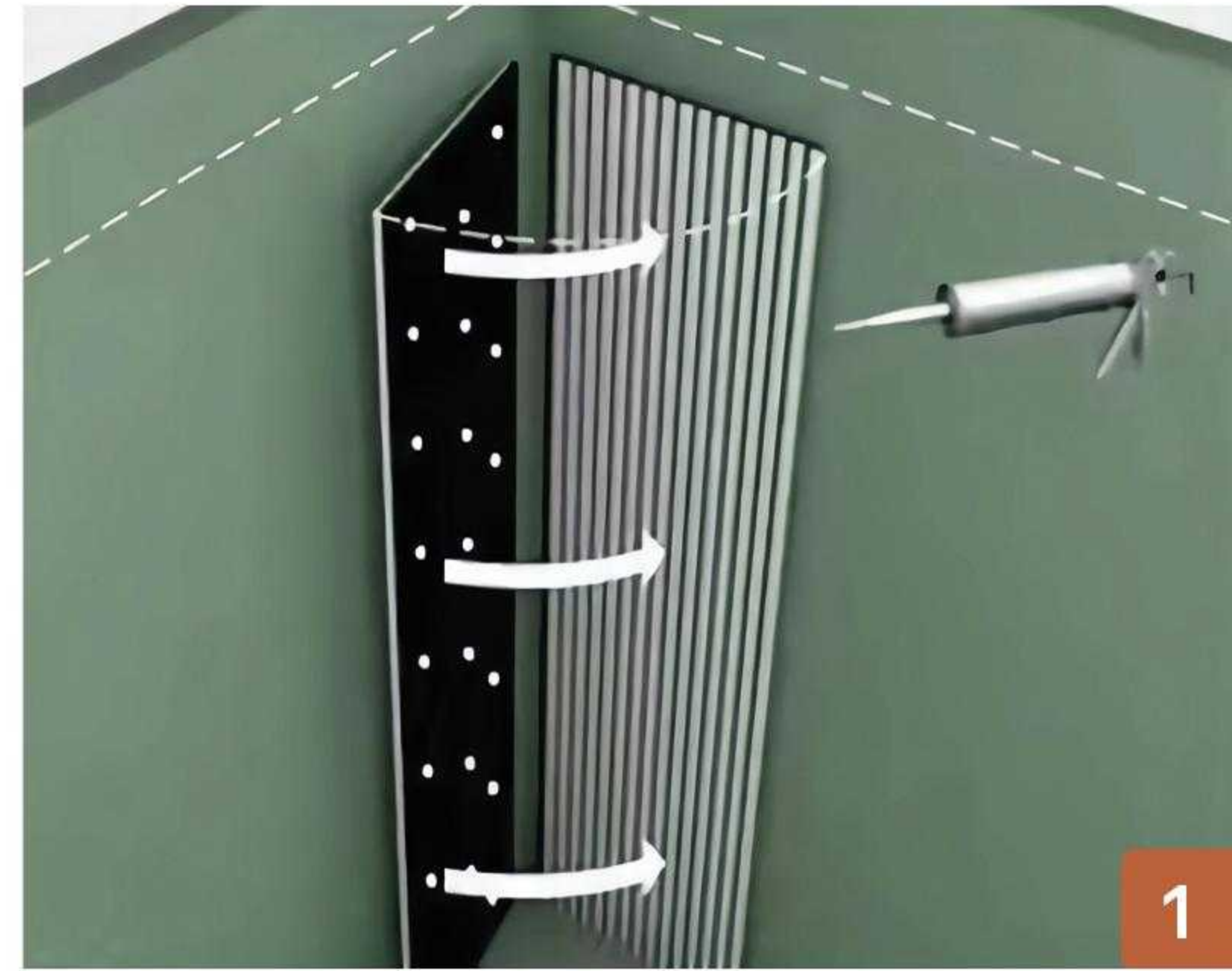

◦ Methods 1

Glue Installation

Directly use construction adhesive or structural adhesive to stick it to the wall.



◦ Methods 2

Screw Installation

Use black screws to attach the backing board to the wall through the polyester acoustic panel. It is recommended to use at least 9 screws per grille panel.



◦ Methods 3

Wooden Battens

Directly screw the grille panel into the wooden battens. For optimal sound absorption, use polyester fiber acoustic panels and leave space behind the panels for Rockwool. This combination will achieve better sound absorption.

08 PU Stone Panel

Hot-selling product series



08 PU Stone Panel

Hot-selling product series

Pu Stone refers to polyurethane stone, also known as artificial rock. It is an artificial stone made from materials such as polyurethane resin, fillers, and pigments through a series of processes.



HOLLOW BRICK

Thickness: 15-30mm
600mm*1200mm*35mm

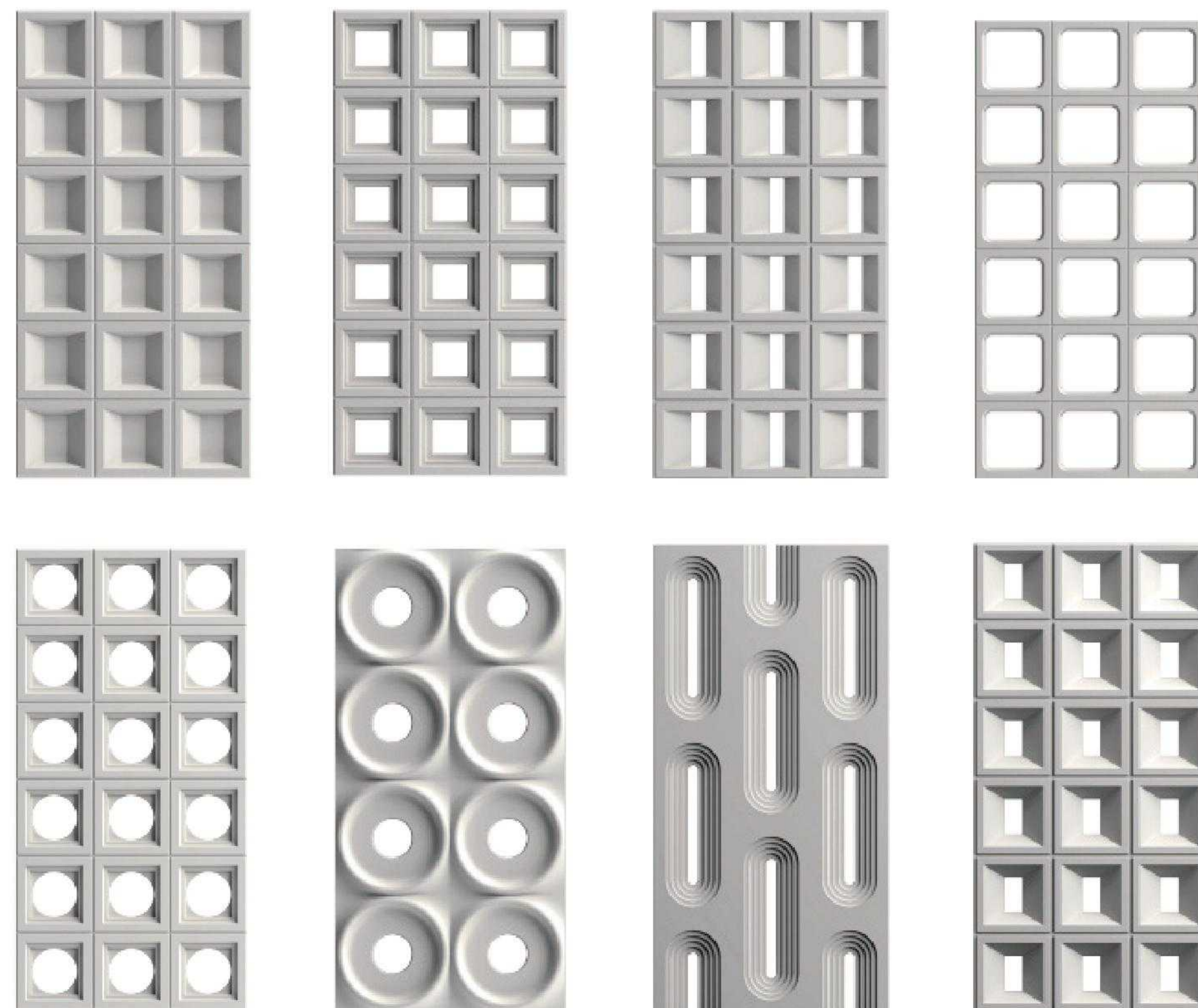

08 PU Stone Panel

Hot-selling product series



PU MOUNTAIN ROCKS

Thickness: 10-80mm
600mm*1200mm*70mm



08 PU Stone Panel
Hot-selling product series



PU BIG SLABS

Thickness: 35mm
600mm*1200mm*35mm

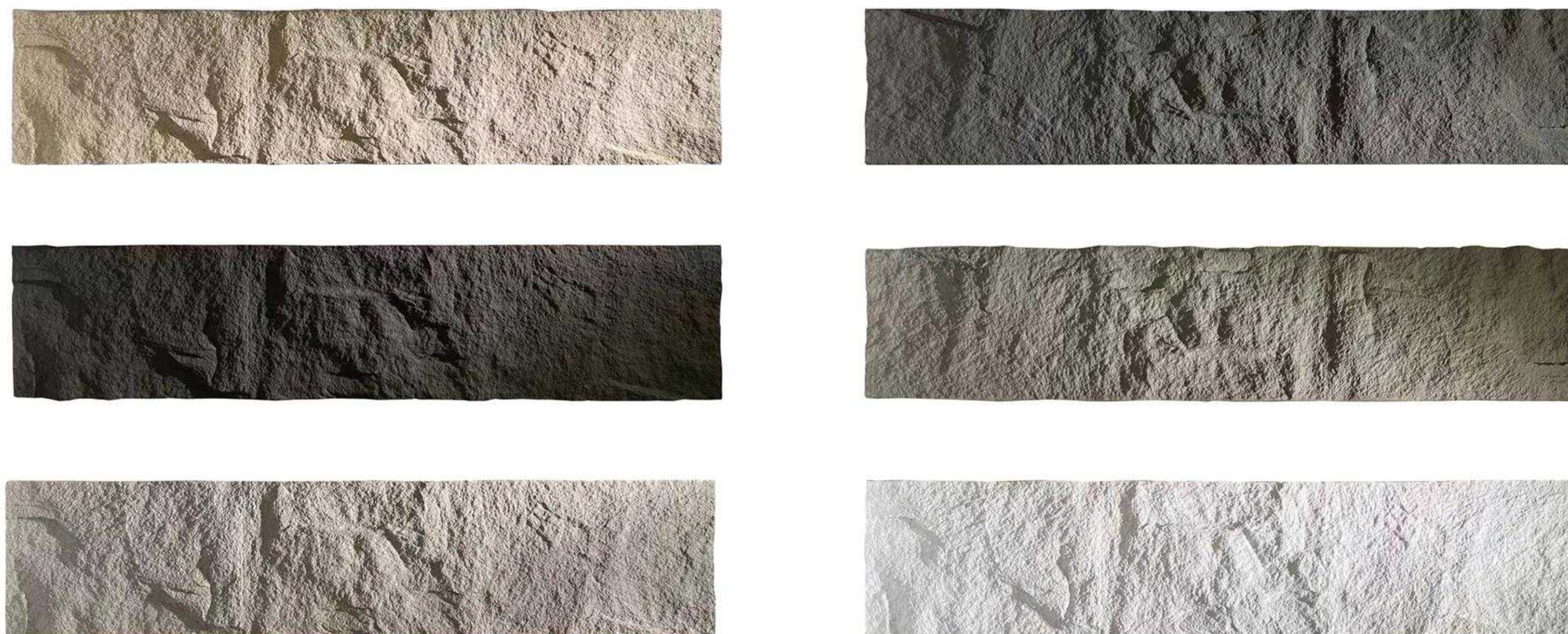

08
Hot-selling product series

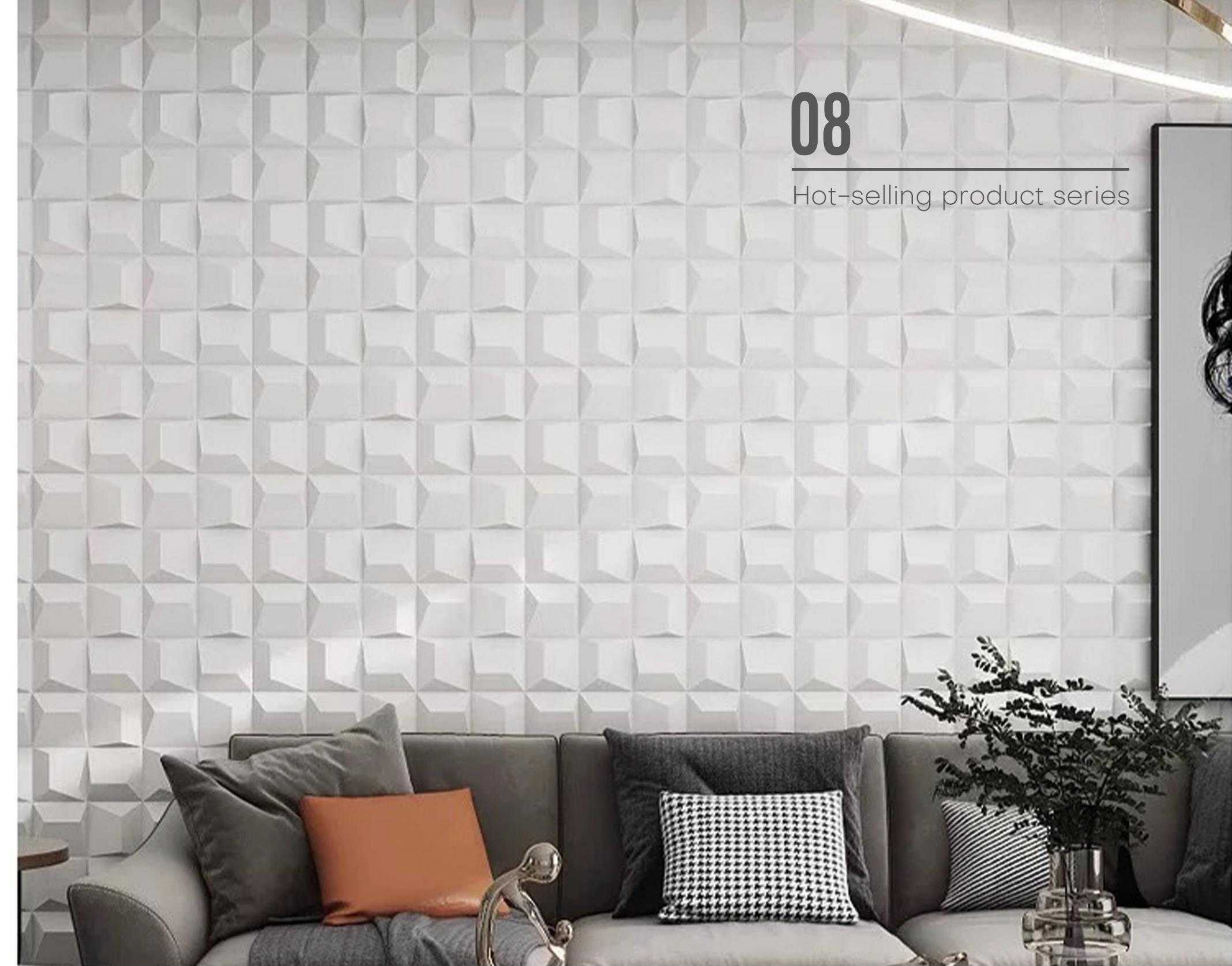

PU GEOMETRY SERIES

Thickness: 10-80mm
600mm*1200mm*22mm



600*1200*22mm



600*1200*22mm

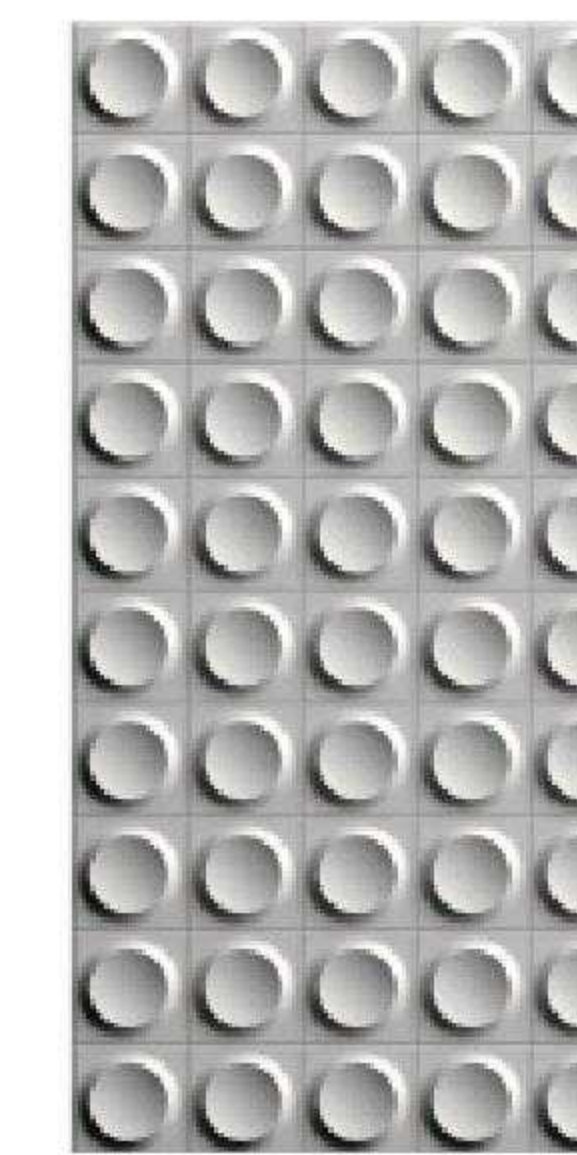

600*1200*22mm

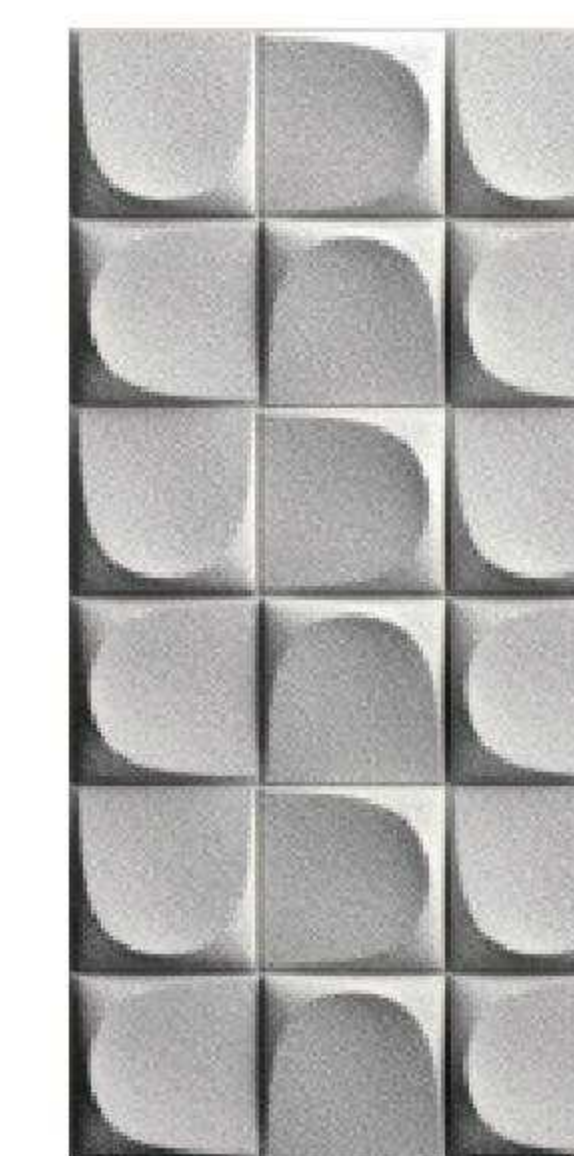

600*1200*35mm



600*1200*22mm

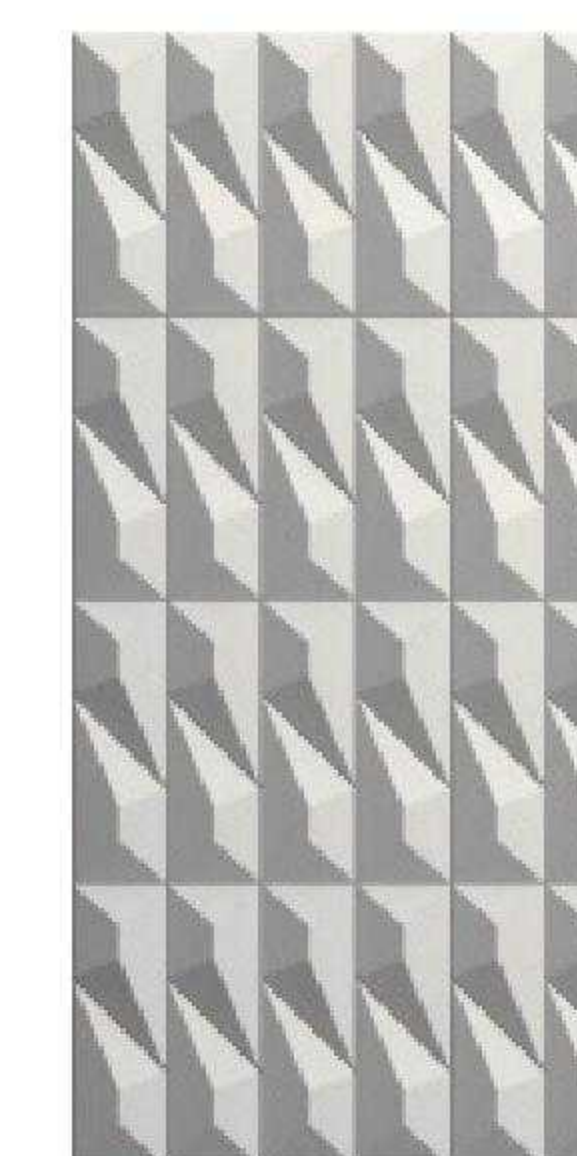

600*1200*22mm

08 PU Stone Panel
Hot-selling product series



STACKED PEAK STONE

Thickness: 10-80mm
600mm*1200mm*50mm



MOUNTAIN ROCK

Thickness: 10-80mm
600mm*1200mm*50mm



08 PU Stone Panel
Hot-selling product series



PU STONE SKIN

Thickness: 35mm
600mm*1200mm*35mm



PU Shale Stone



PU Stone Skin



PU Mushroom Stone

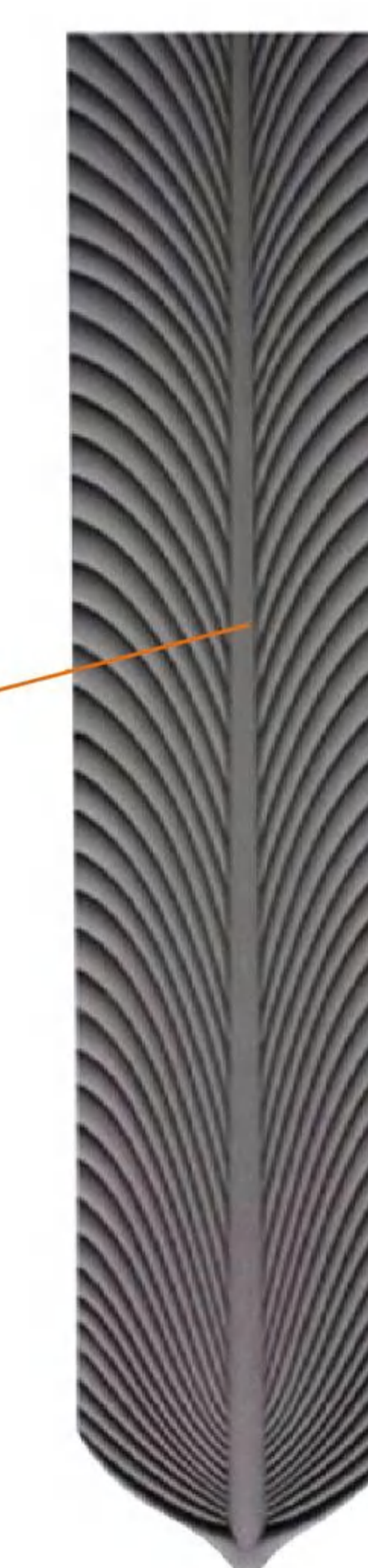
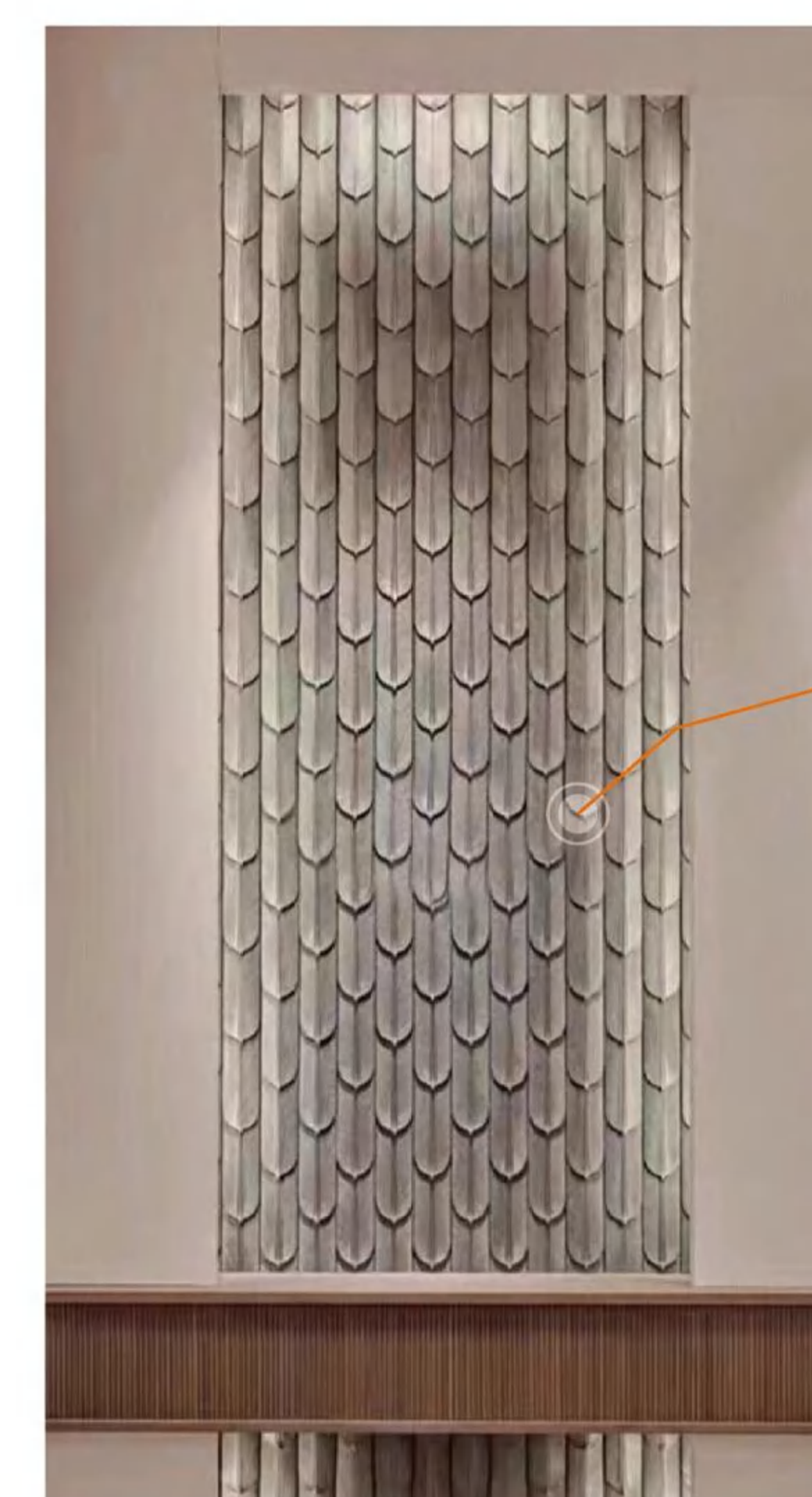

PU FEATHER STONE

Thickness: 20-50mm
900mm*200mm*40mm

08 PU Stone Panel

Installation Method



◦ Step 1

Cutting PU Stone Panels

Based on the measurements, use a saw to cut the PU stone panels to fit the dimensions of the installation area.



◦ Step 2

Applying Adhesive

Evenly apply an appropriate amount of specialized adhesive to the back of the PU stone panels.



◦ Step 3

Installing PU Stone Panels

Ensure the installation surface is clean, flat, and dry. Carefully place the PU stone panels with adhesive onto the marked positions. Press the panels firmly to ensure they adhere tightly to the installation surface.



◦ Step 4

Nailing for Reinforcement

Use a nail gun to further secure the PU stone panels.

09 Outdoor Wall Panel

Hot-selling product series

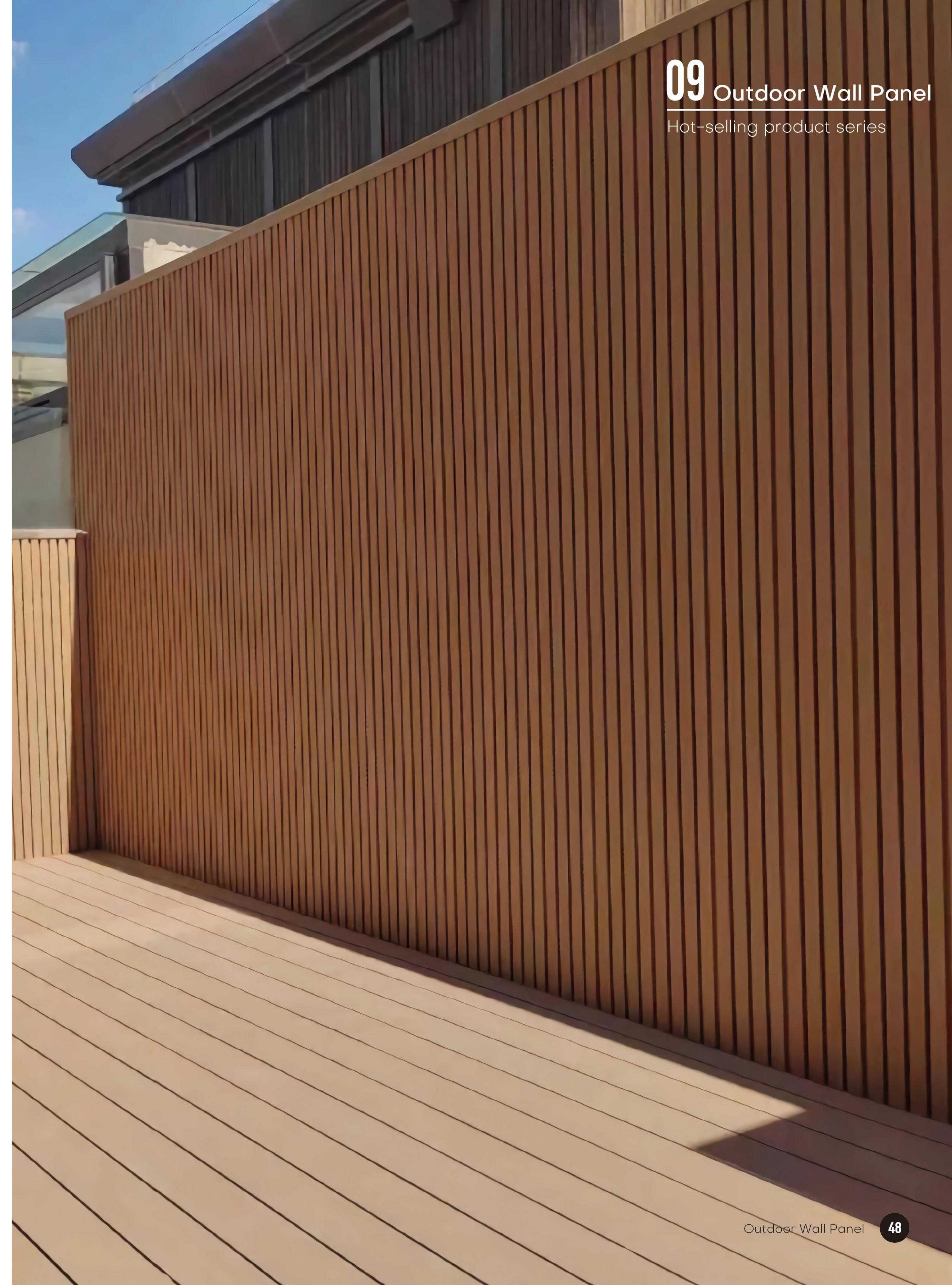



Sanding



Light Wood Grain



3d embossed

WPC Classic Wall Panel



CSP21926A

W 219mm
H 26mm

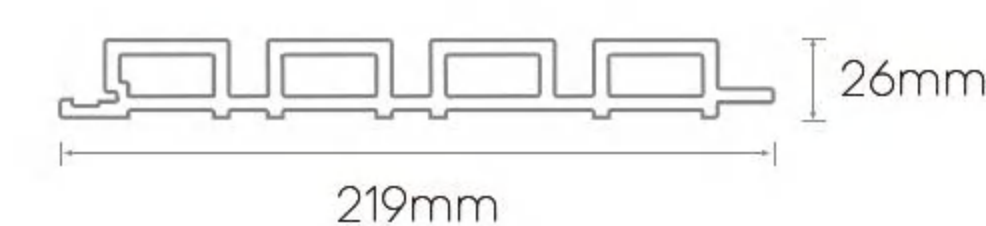

CSP14821A

W 148mm
H 21mm

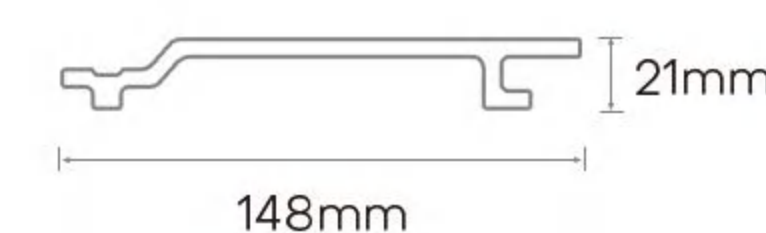

CSP15621A

W 156mm
H 21mm



Wood Grain



Sanding

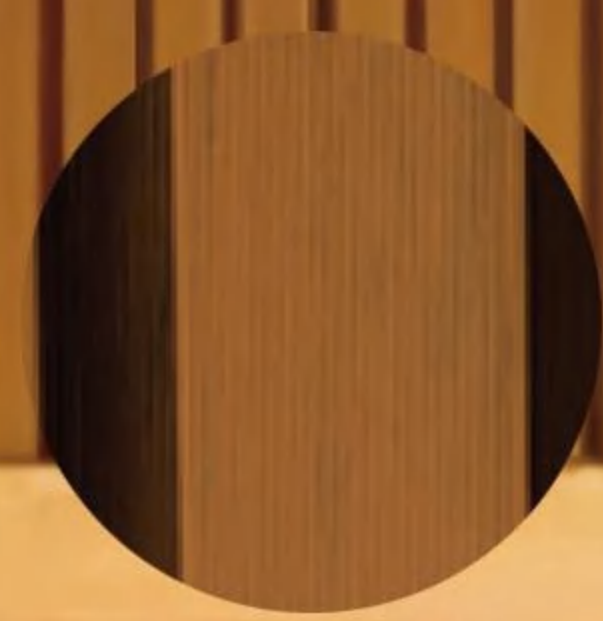

Straight Line

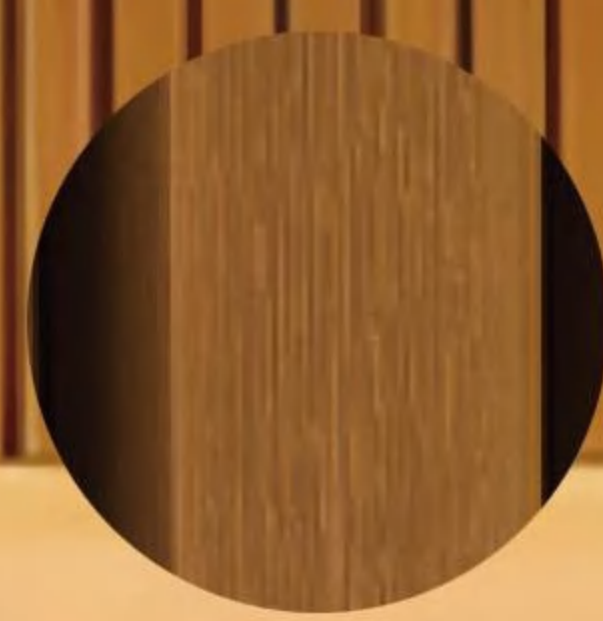

Embossed

Co-extrusion Wall Panel



CSP21926B

W 219mm
H 26mm



CSP21926BH

W 219mm
H 26mm



CSP15621B

W 156mm
H 21mm

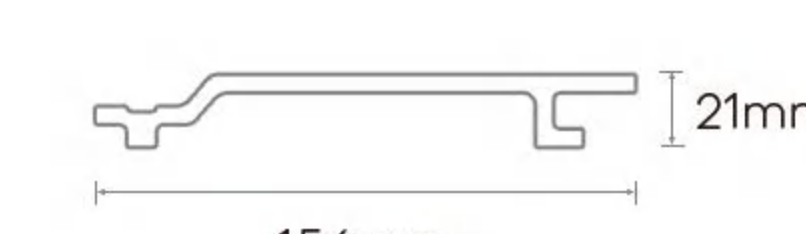

09 Outdoor Wall Panel

Installation Method

Accessories



PJJX-1

PJFB-2

PJFB-3

Installation



Step 1

Fix the studs to the wall.



Step 2

Secure the product to the studs.



Step 3

Arrange the products in a front-to-back order.



Step 4

Installation is complete.

WPC Classic Timber Tube



Co-extrusion Timber Tube



Fence Post

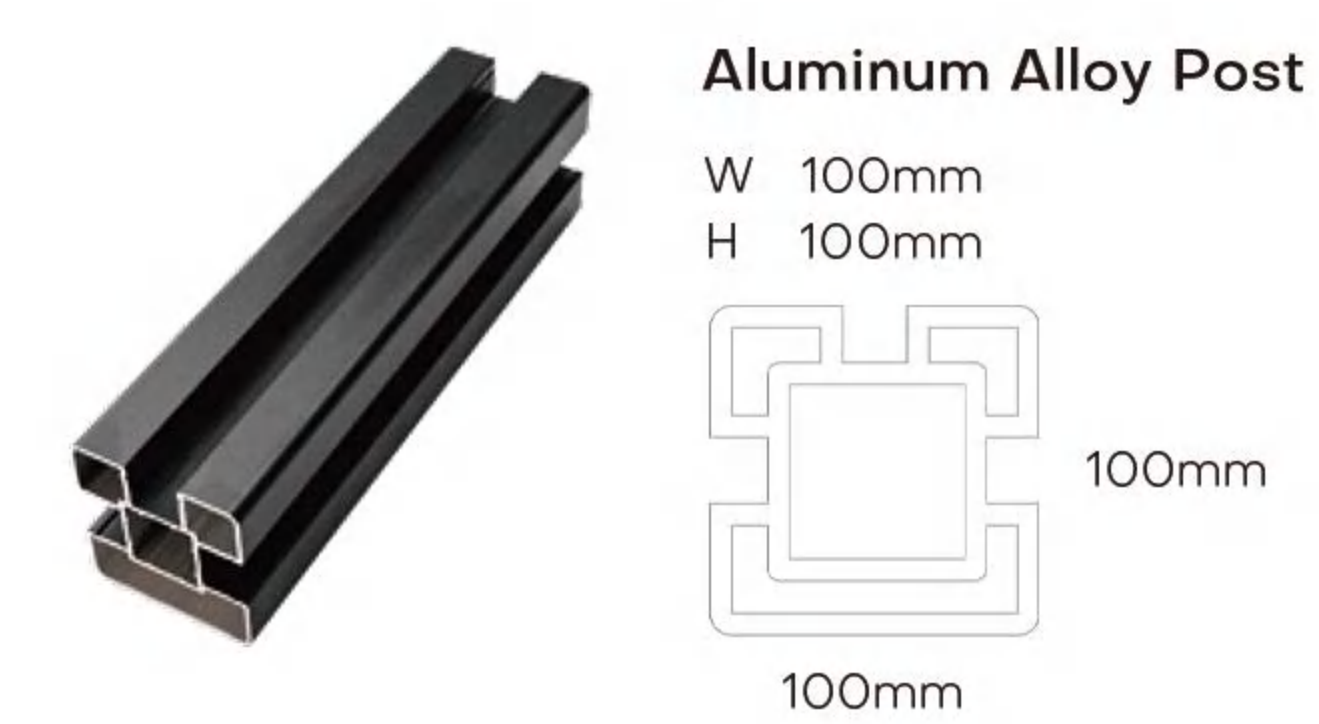

10 Outdoor Decking

Hot-selling product series



10 Outdoor Decking

Hot-selling product series

WPC decking stands for wood plastic composite decking. It is also called composite decking, or WPC flooring. Environmentally Friendly, Durable, Extremely Low-Maintenance, Scratch-Resistant, Anti-Slip, Waterproof, Fireproof, and Long-Lasting.

WPC Classic Decking

CSD14025AS

W 140mm
H 25mm
L 2900mm

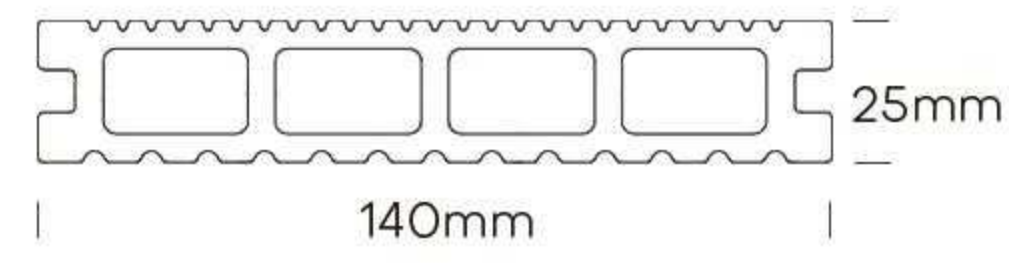

CSD14025AR

W 140mm
H 25mm
L 2900mm

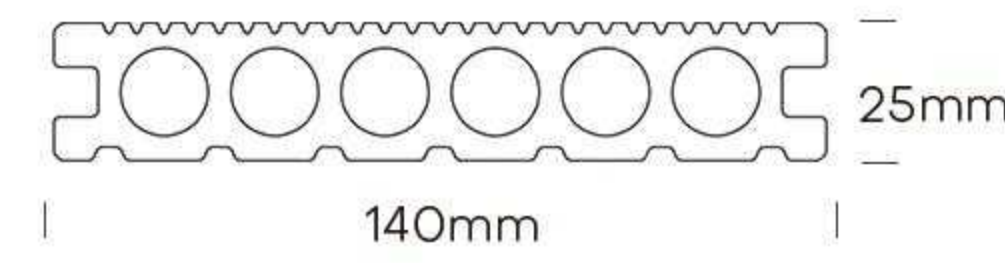
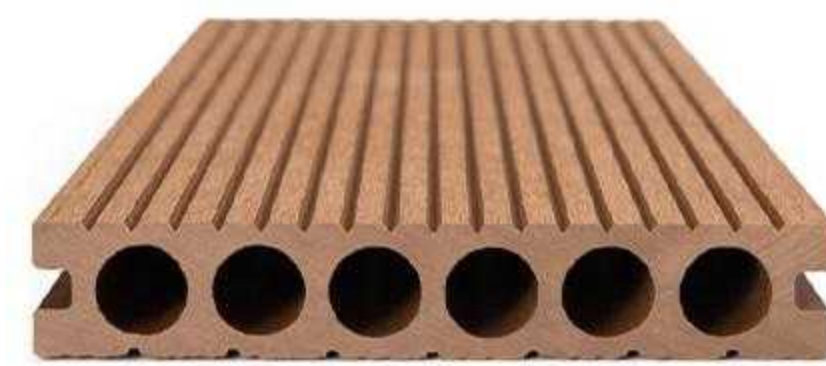

CSD14025A

W 140mm/150mm
H 25mm
L 2900mm

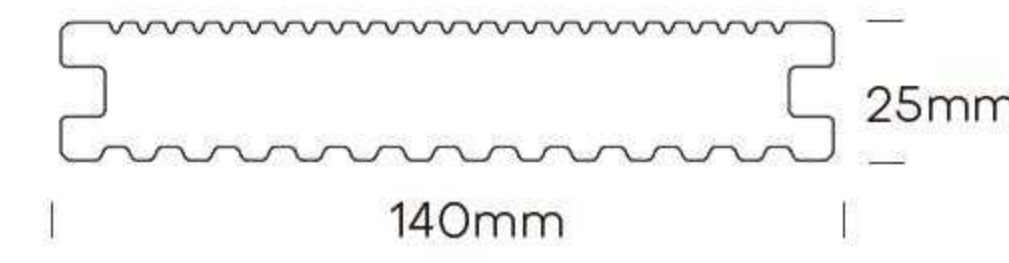

WPC Co-extrusion Decking

CSD13823B

W 138mm
H 23mm
L 2900mm

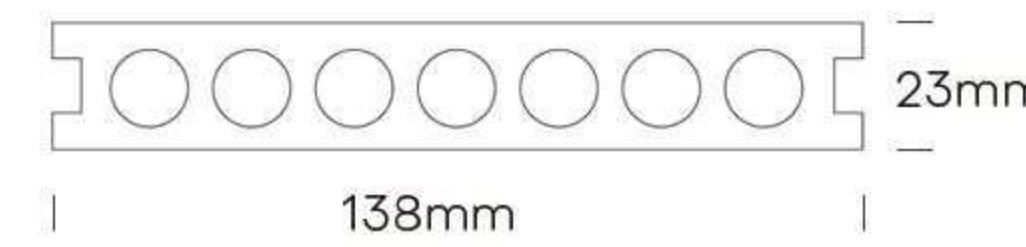

CSD14023B

W 140mm
H 23mm
L 2900mm



WPC 3D Embossed Decking

CSD14025AS-3D

W 140mm
H 25mm
L 2900mm

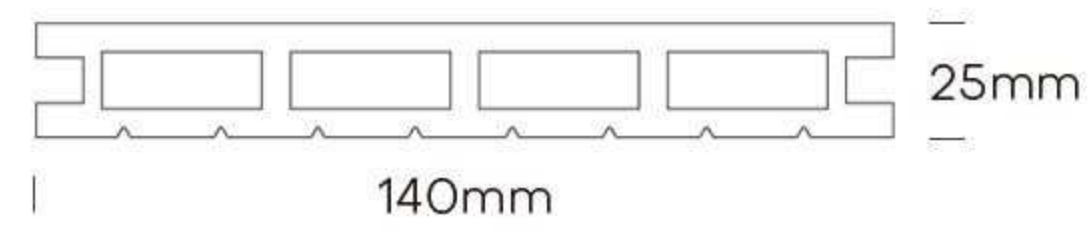

CSD14025AR-3D

W 140mm
H 25mm
L 2900mm

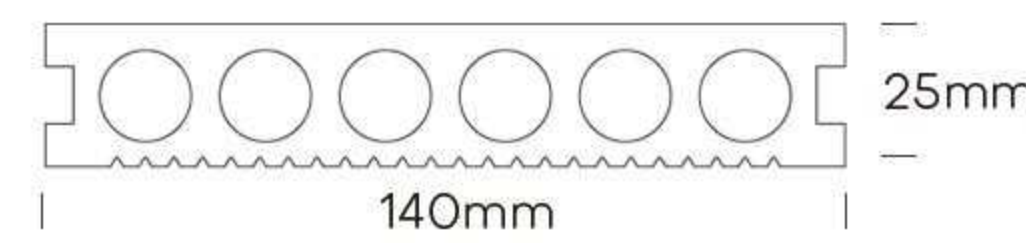

First Generation Color Option



WPC Co-extrusion Decking Color Option

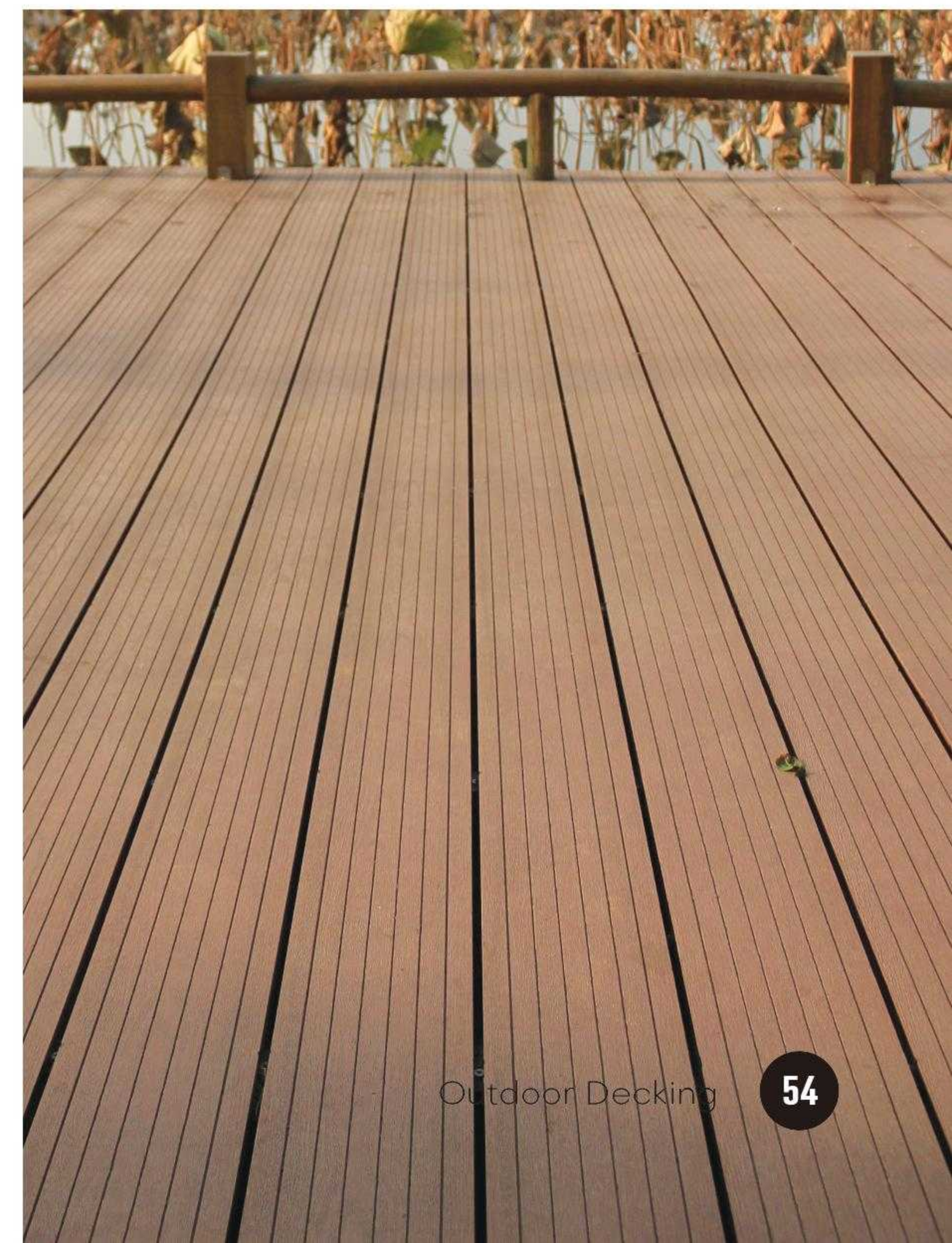
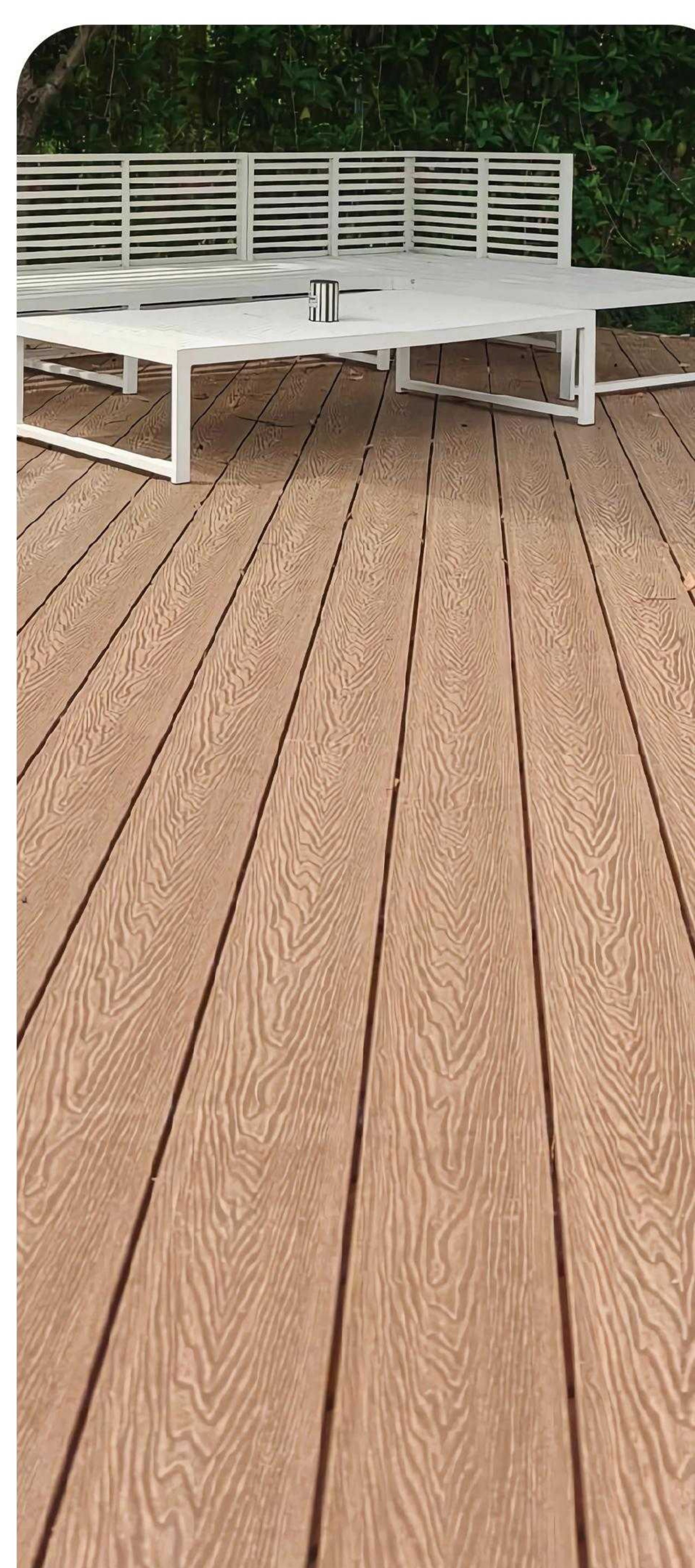

10 Outdoor Decking

Installation Method

◦ Accessories



WPC Keel



A-1



Plastic buckle



Galvanized clip

◦ Installation

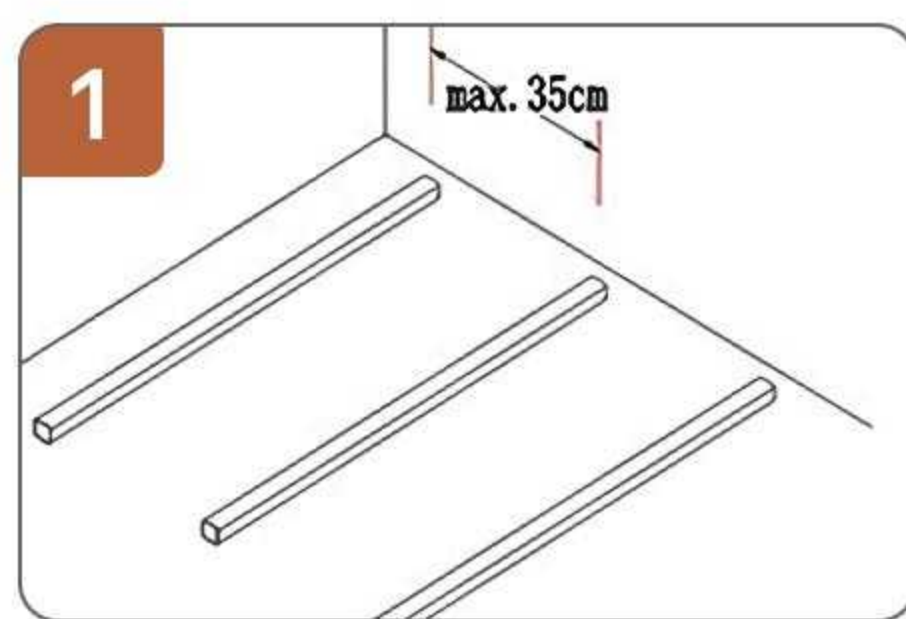

1. Install the joists, ensuring that the distance between two joists does not exceed 35 cm.

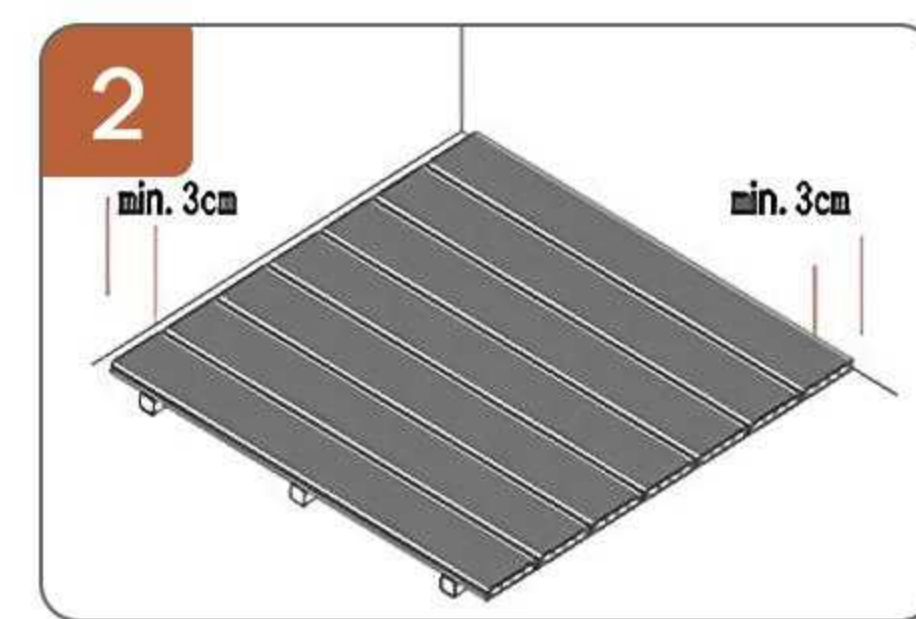

2. Leave a 3 cm gap between the decking and the building.

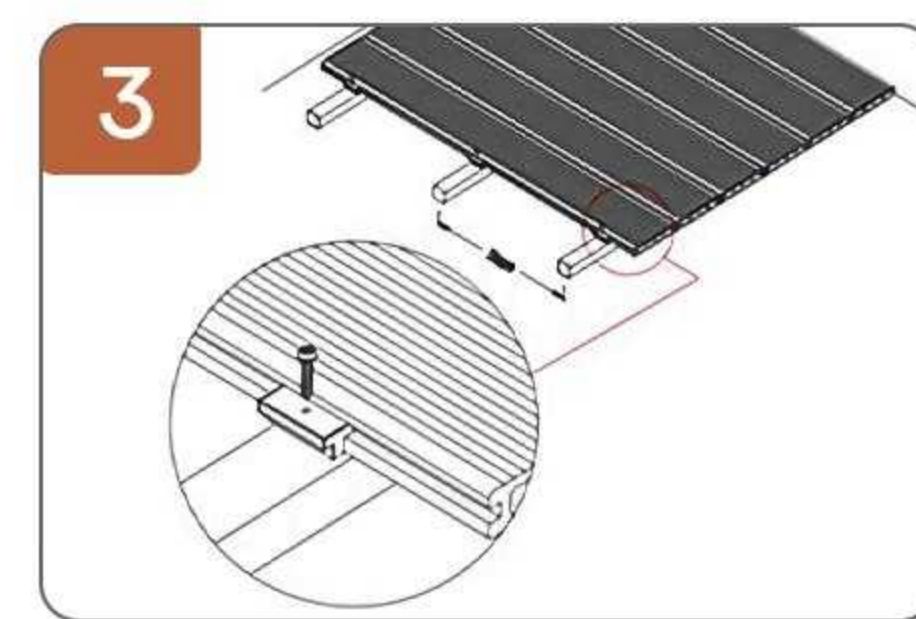
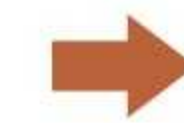

3. Secure the decking to the joists using metal fasteners.

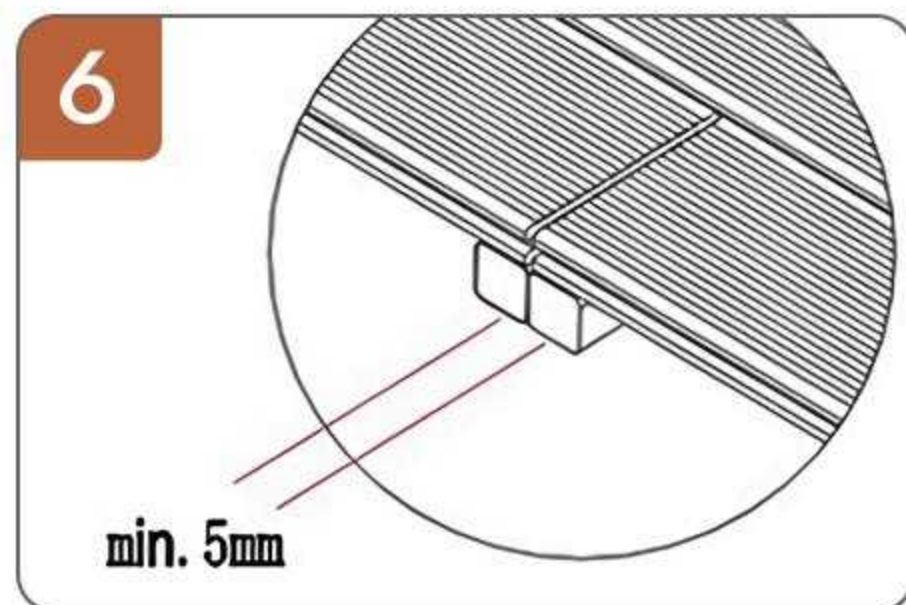

6. Ensure a gap of at least 5 mm between two decking boards.

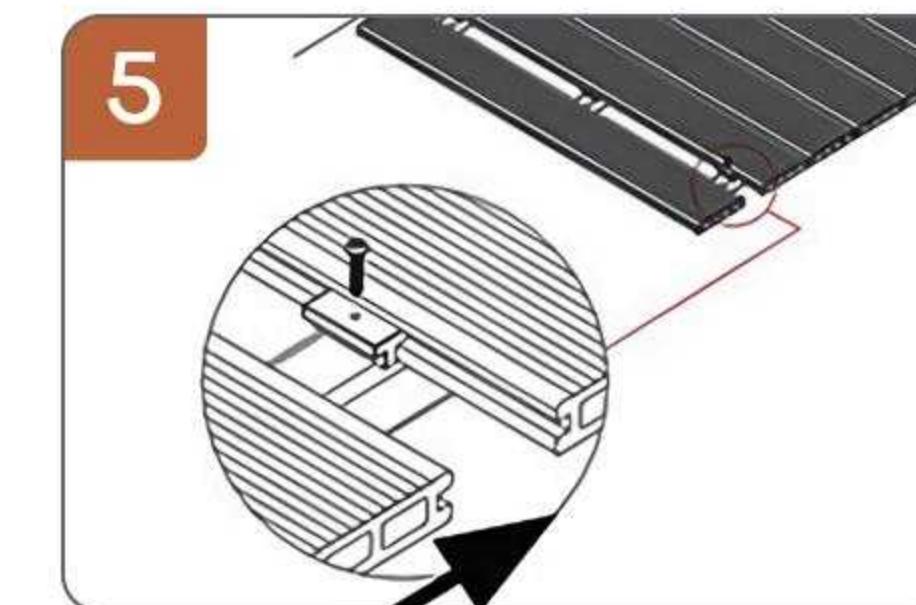

5. Connect and secure two decking boards to the joists using metal clips.

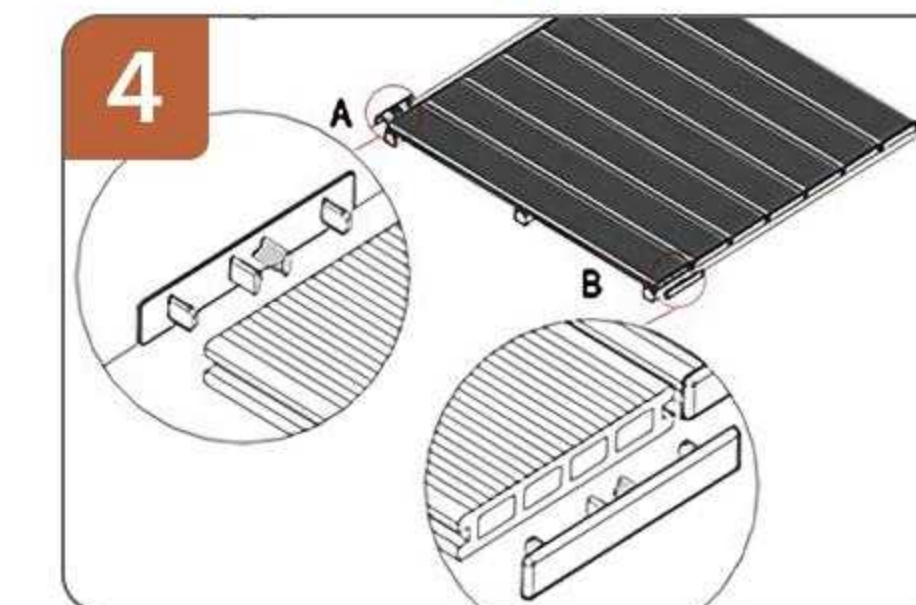

4. Seal the ends of the hollow decking boards.

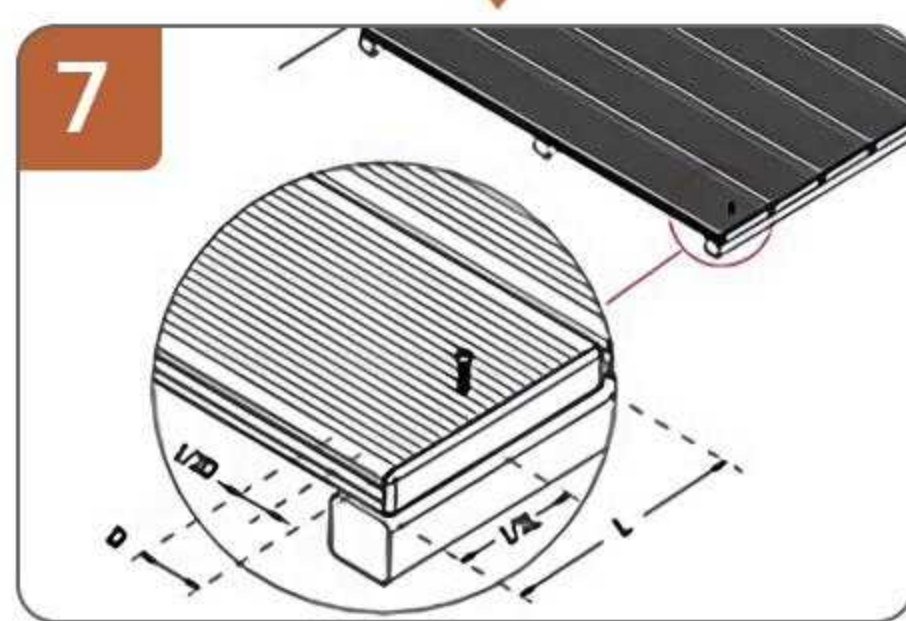

7. Fix the first and last decking boards to the surface or side using screws.

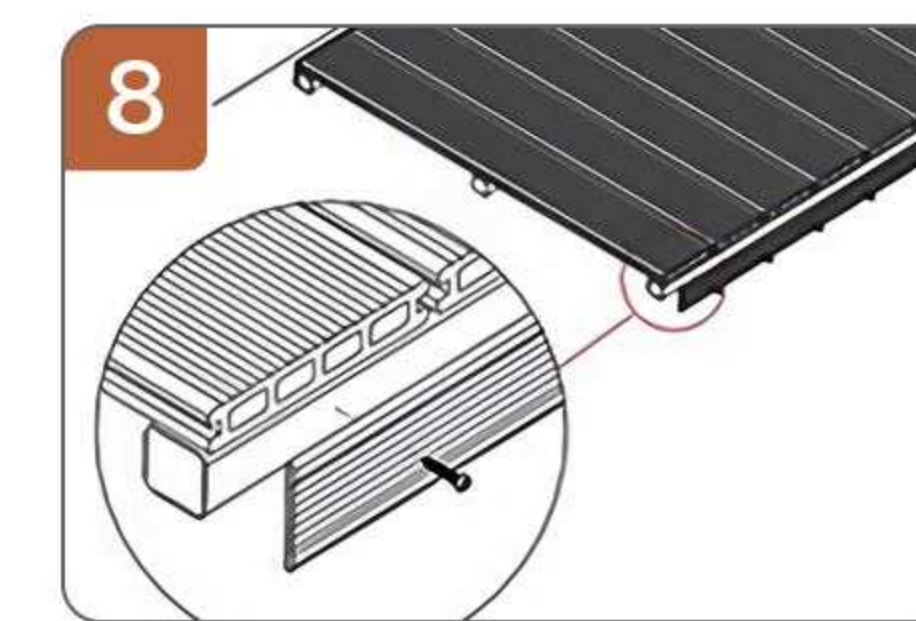
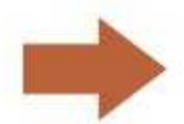

8. Install side fascia boards to finish.

AesthEdge

WE KEEP MOVING
FORWARD



www.aesthedge.com

THANK YOU.