

**AesthEdge**

[www.aesthedge.com](http://www.aesthedge.com)

**AesthEdge**



+8618953955575



[angela@aesthedge.com](mailto:angela@aesthedge.com)



[www.aesthedge.com](http://www.aesthedge.com)



Rm1103, A10Building, Lushang Center, Guangzhou Road,  
Lanshan District, Linyi City, Shandong Province, China

**HOT SELLING PRODUCTS  
CATALOGUE**





# AesthEdge

## Contents

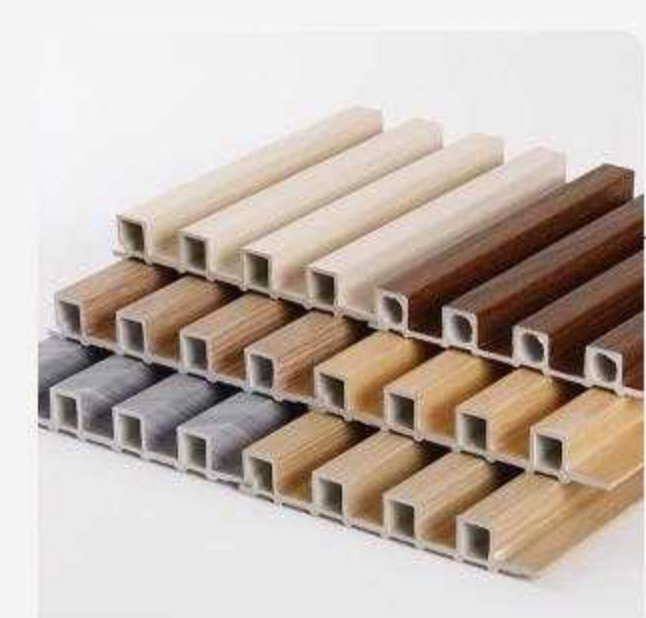

01

WPC Wall Panel

03-9



02

WPC Ceiling

10-12

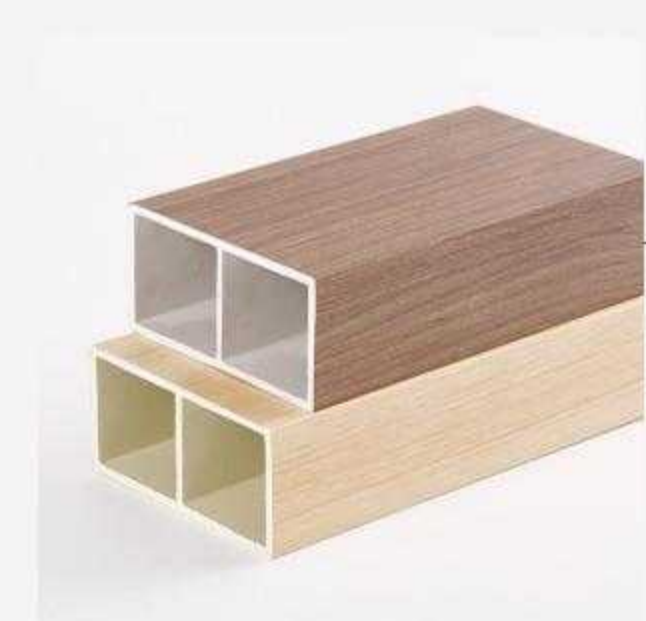

03

WPC Timber Tube

13-15



04

Bamboo Charcoal  
Wood Veneer

16-23



05

PVC Marble Sheet

24-31



07

Slat Acoustic Panel

36-39



09

Composite Cladding

48-51



06

PS Wall Panel

32-35



08

PU Stone Panel

40-47



10

Composite Decking

52-56



## AesthEdge Presentation

AesthEdge specializes in designing, manufacturing, and distributing innovative, eco-friendly decor coverings and wall protection solutions. Our main products include WPC Panels, PVC Marble Sheets, Bamboo Charcoal Wood Veneers, PS Wall Panels, Slat Acoustic Panels, PU Stone Panels, Composite Cladding, Composite Decking, and related accessories.



**SINCE 2005**

19 years exported to more than 60+countries



**60,000**

Covering a land-area of about 60,000 square meters



**35+**

A 35 person sales team and quick response



Home



Facility



Hotel



Office



Sport Area



Factory



Public Housing



School



Retail Store



Transport

## CREATING COMFORTABLE

## NATURAL AESTHETICS

Since the establishment, AesthEdge has adhered to the principles of prioritizing customers, maintaining a strong reputation, focusing on quality, and delivering exceptional service. We continually develop new materials, innovate designs, and enhance our quality management system. This enables us to provide comprehensive solutions and offer OEM and ODM services to our customers.

## WE CARE /WE ACT

Our Commitments for a Sustainable future



Using sustainable materials



Carbonfootprint  
-20 % kg



Recyclable

[www.aesthedge.com](http://www.aesthedge.com)



# 01 WPC Wall Panel

Hot-selling product series

The WPC Wall Panel is mainly a kind of wall decoration board made of wood-plastic material. Because the cross section is like the WPCWall Panel, it is called the WPC Wall Panel.

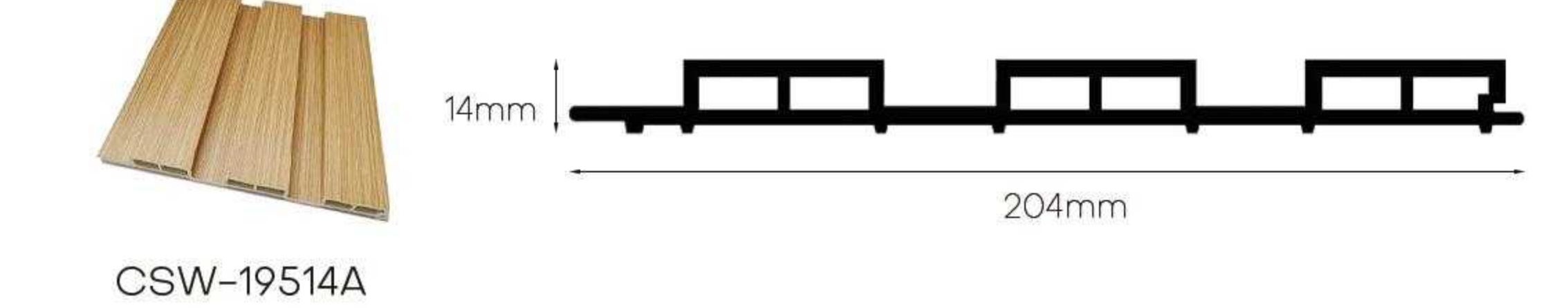
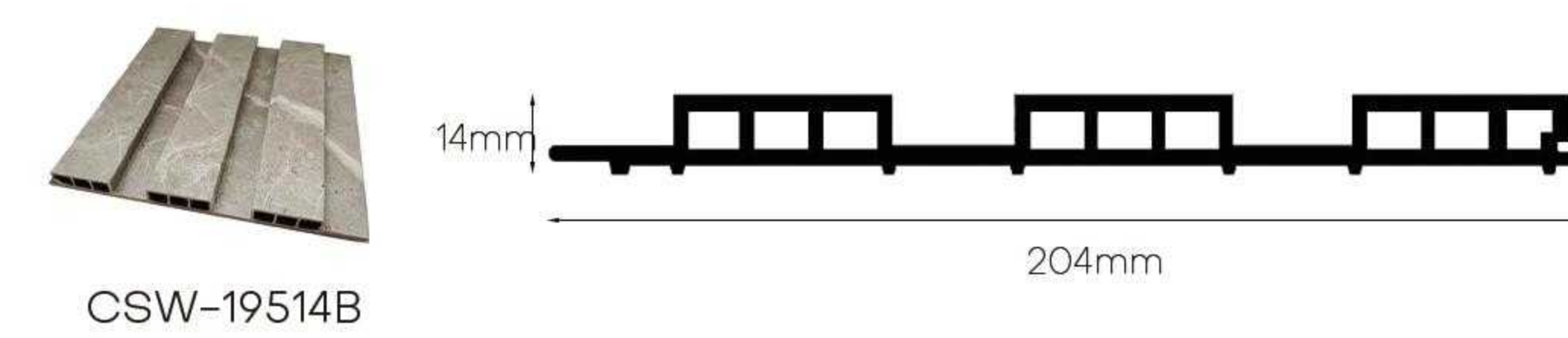
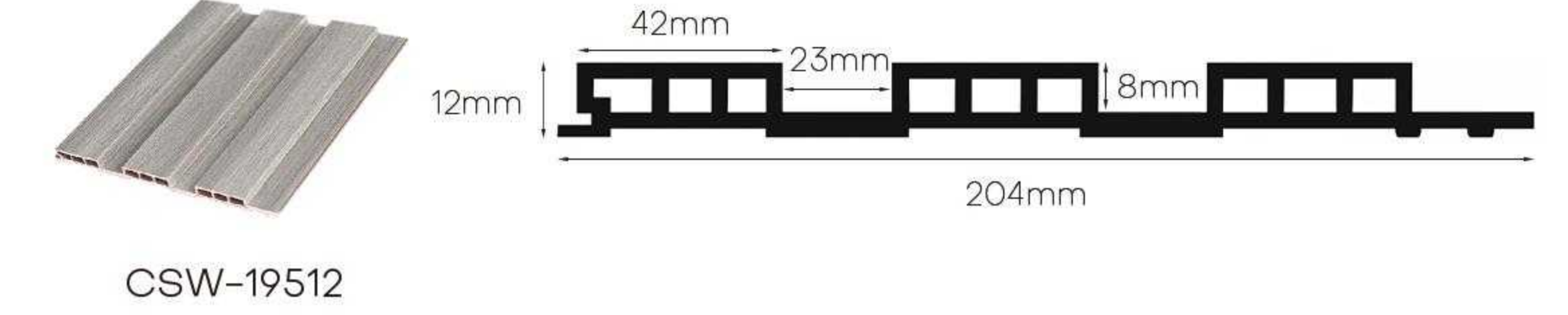
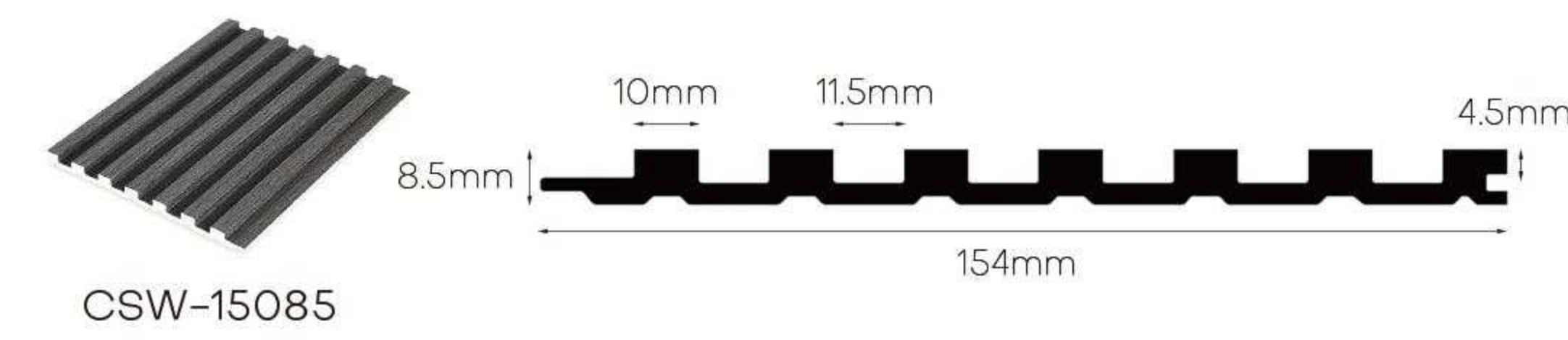
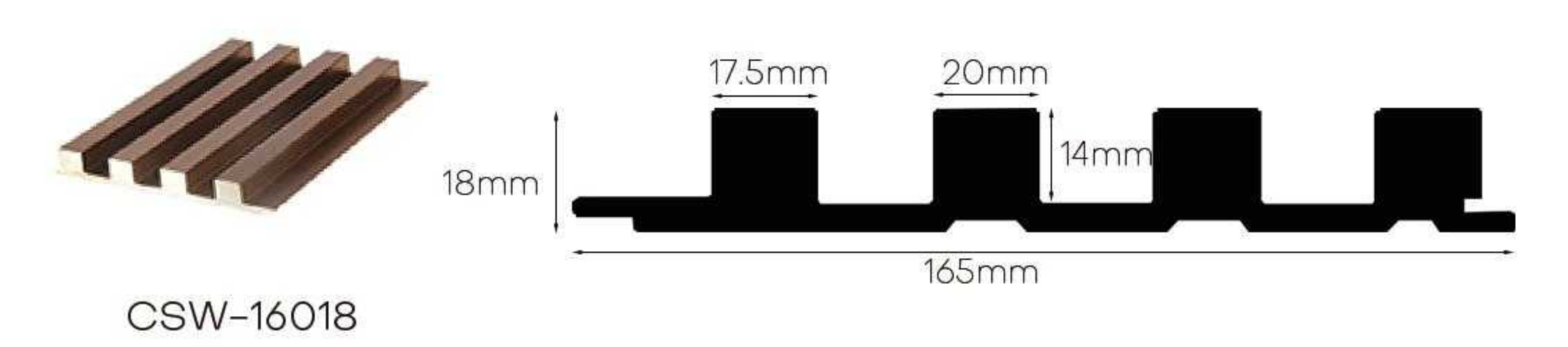
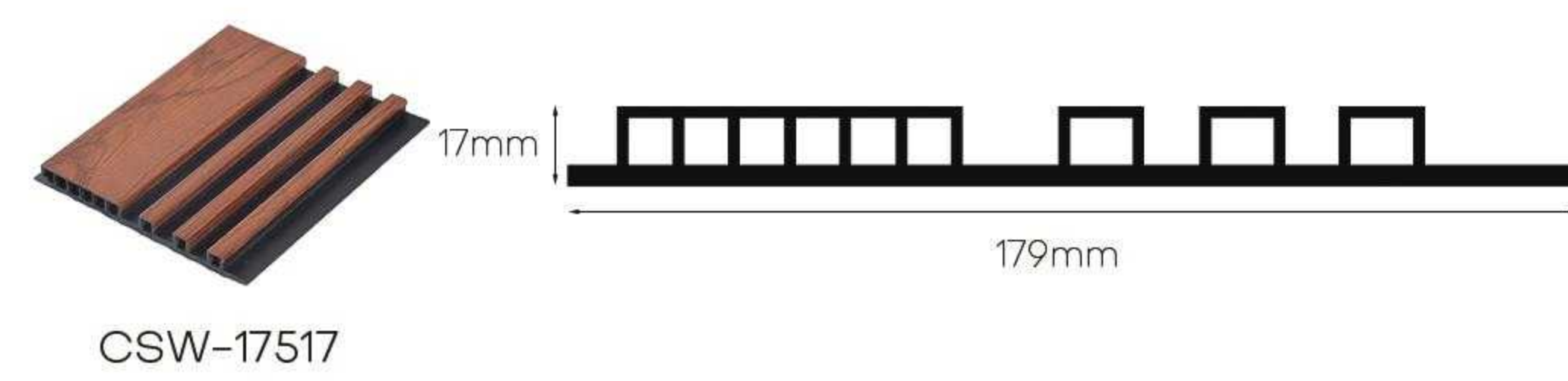
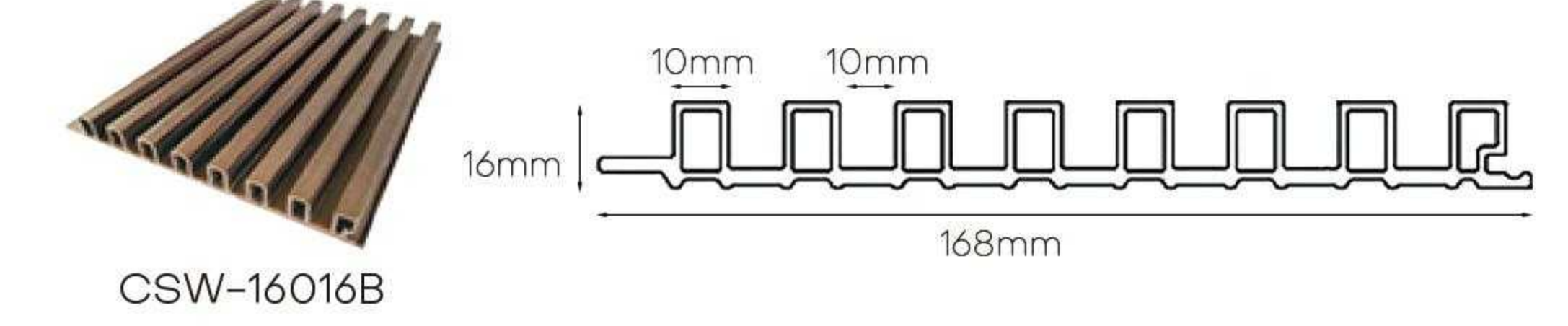
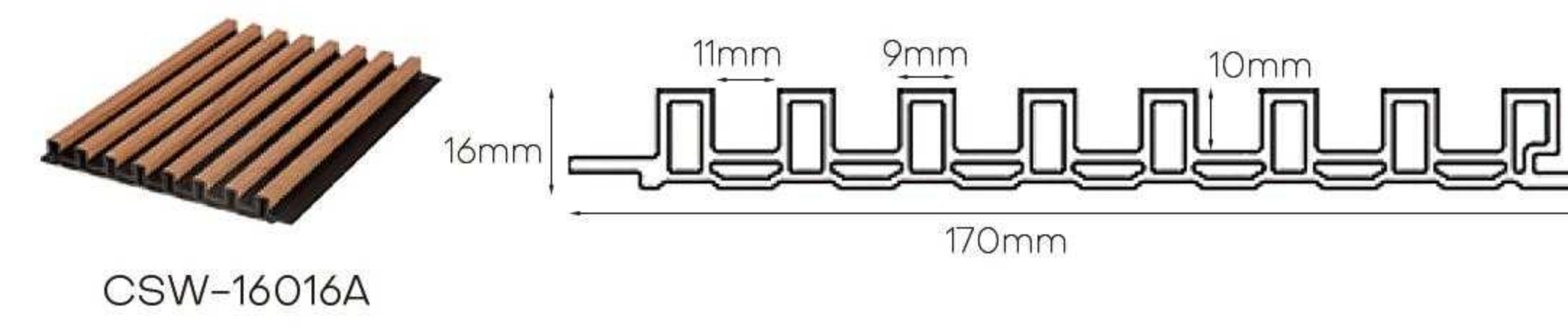
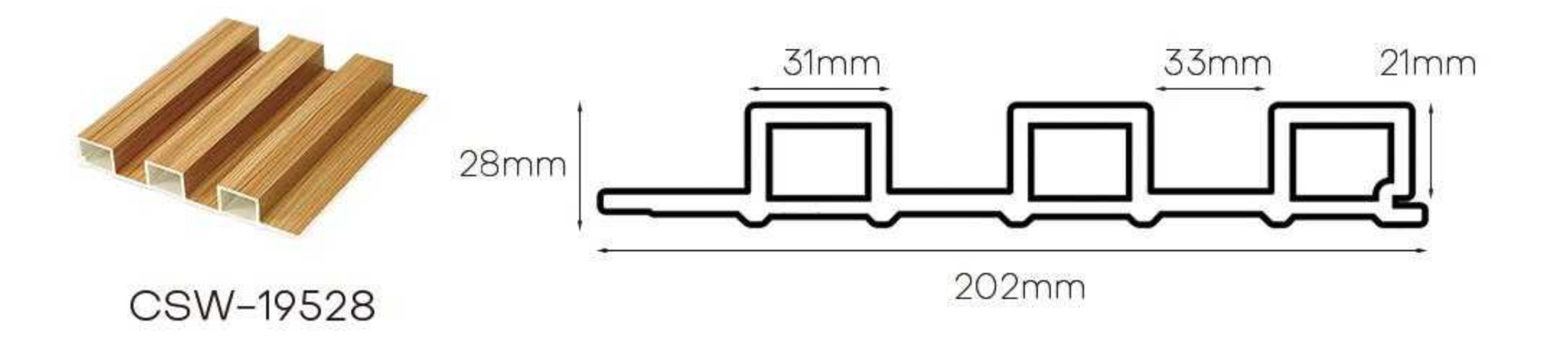
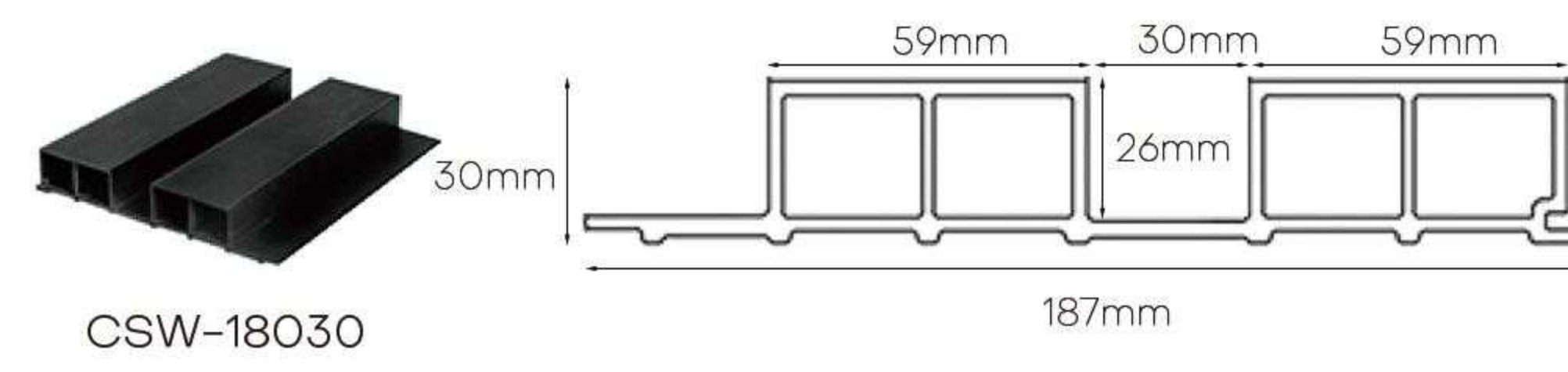
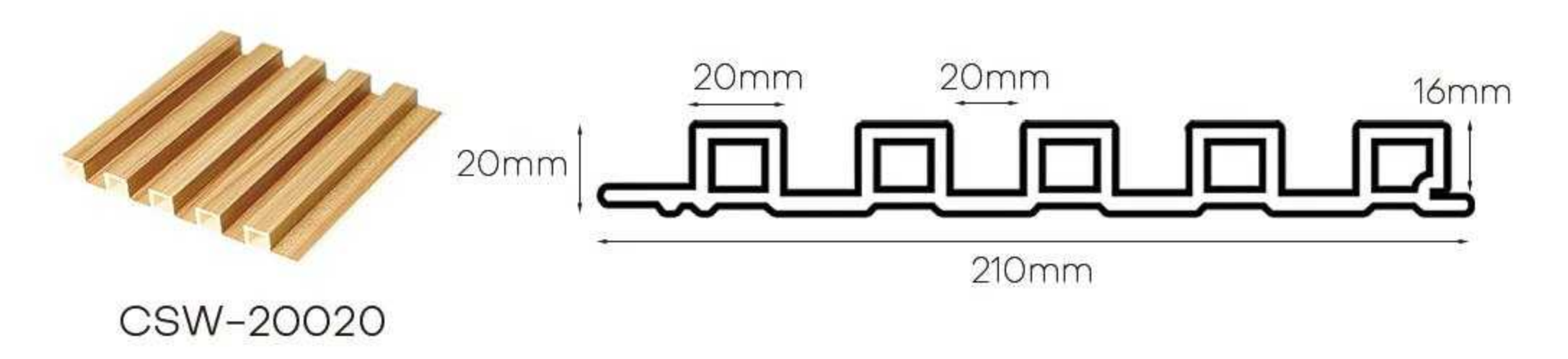
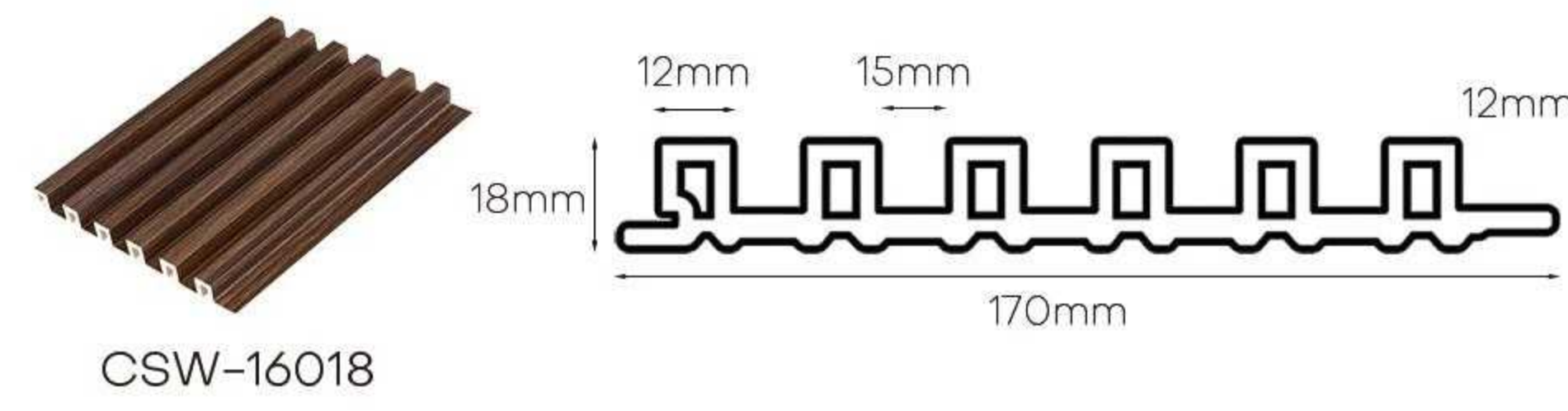
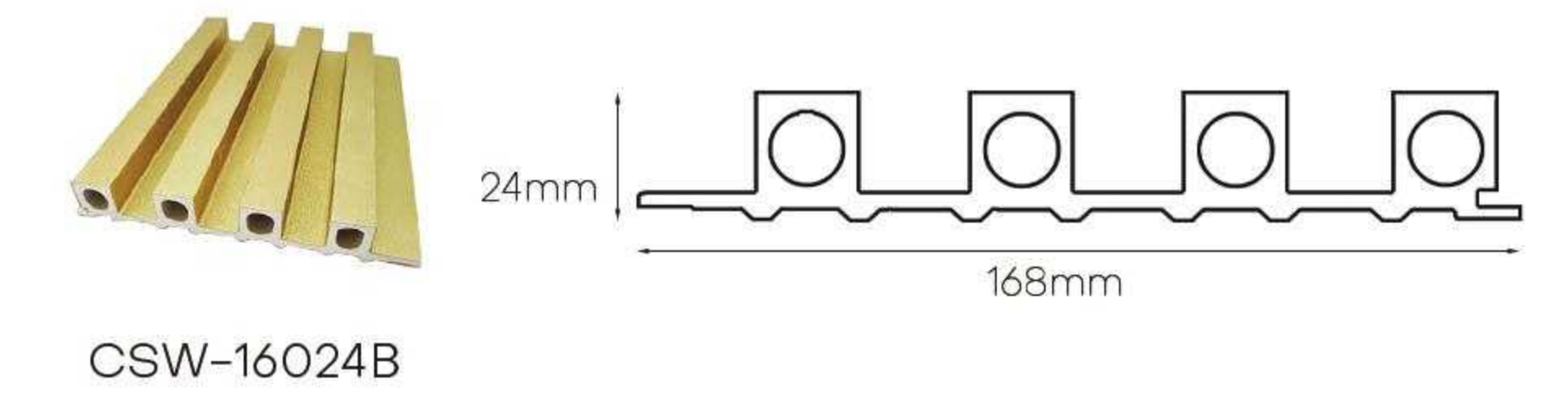
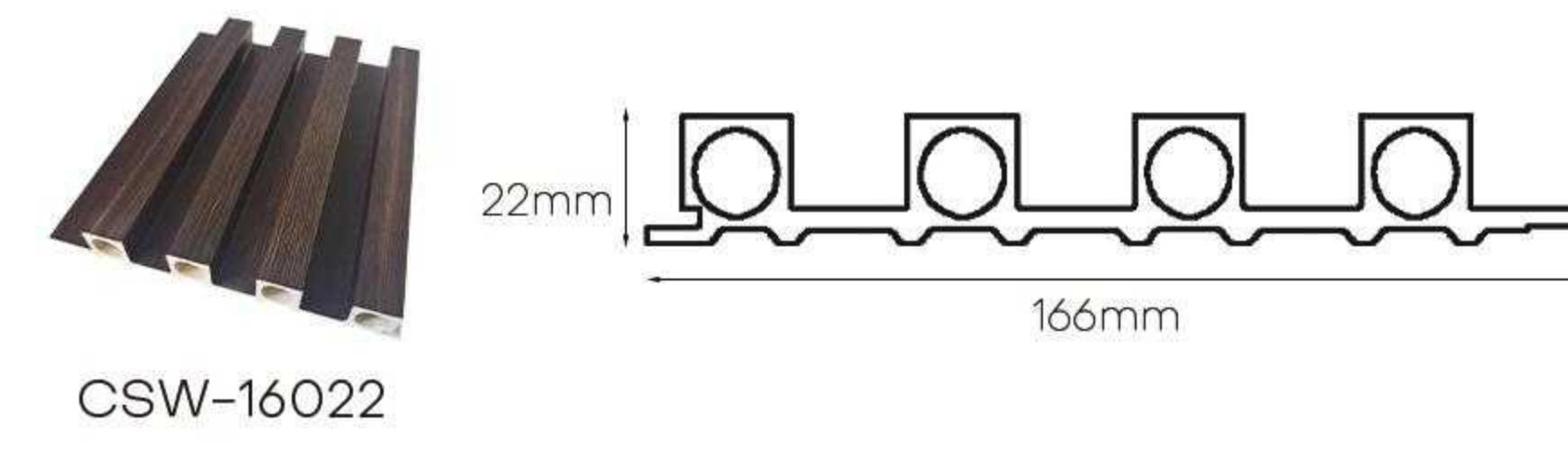
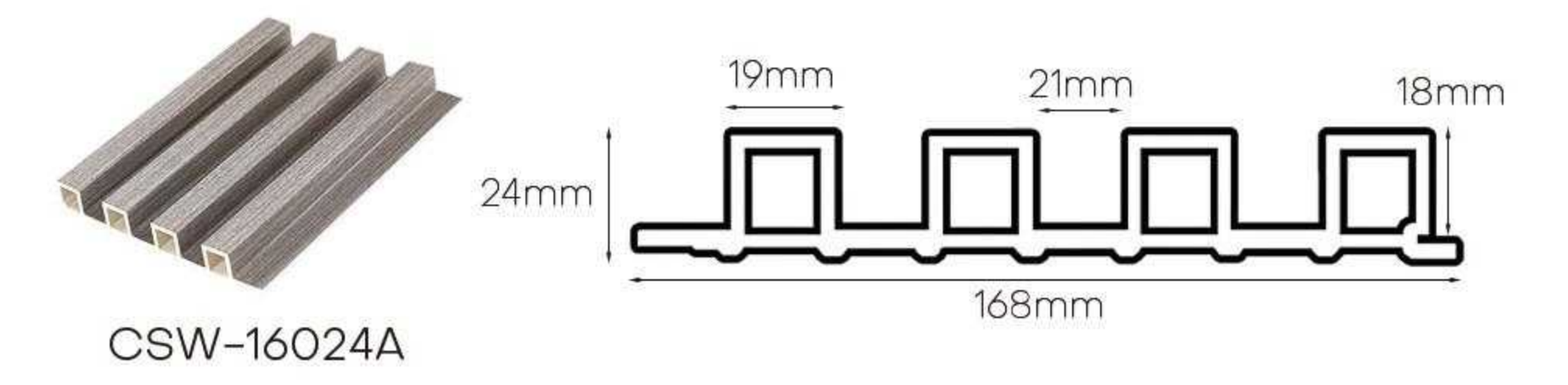
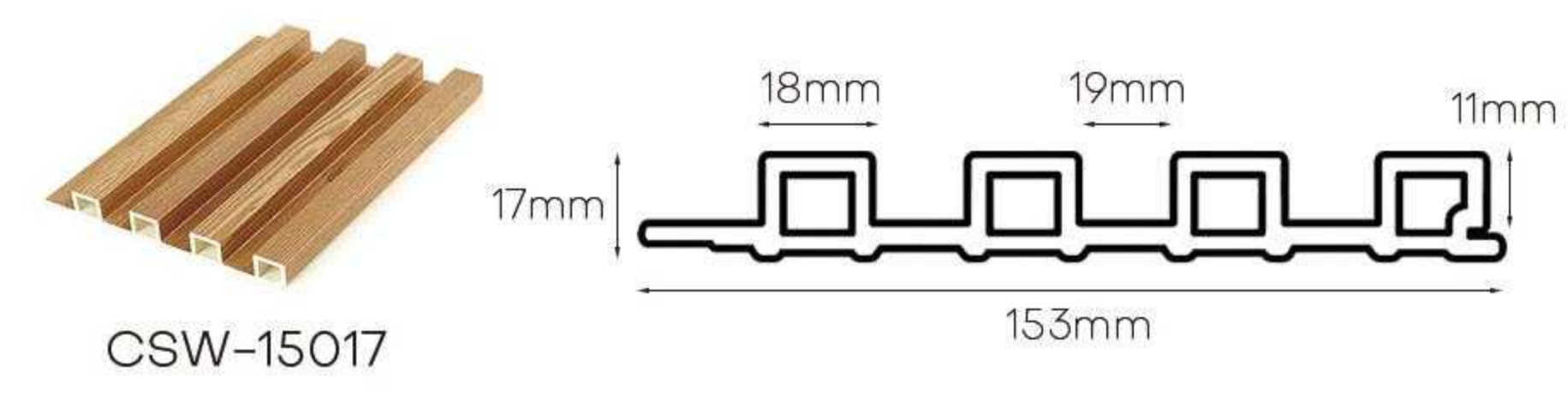
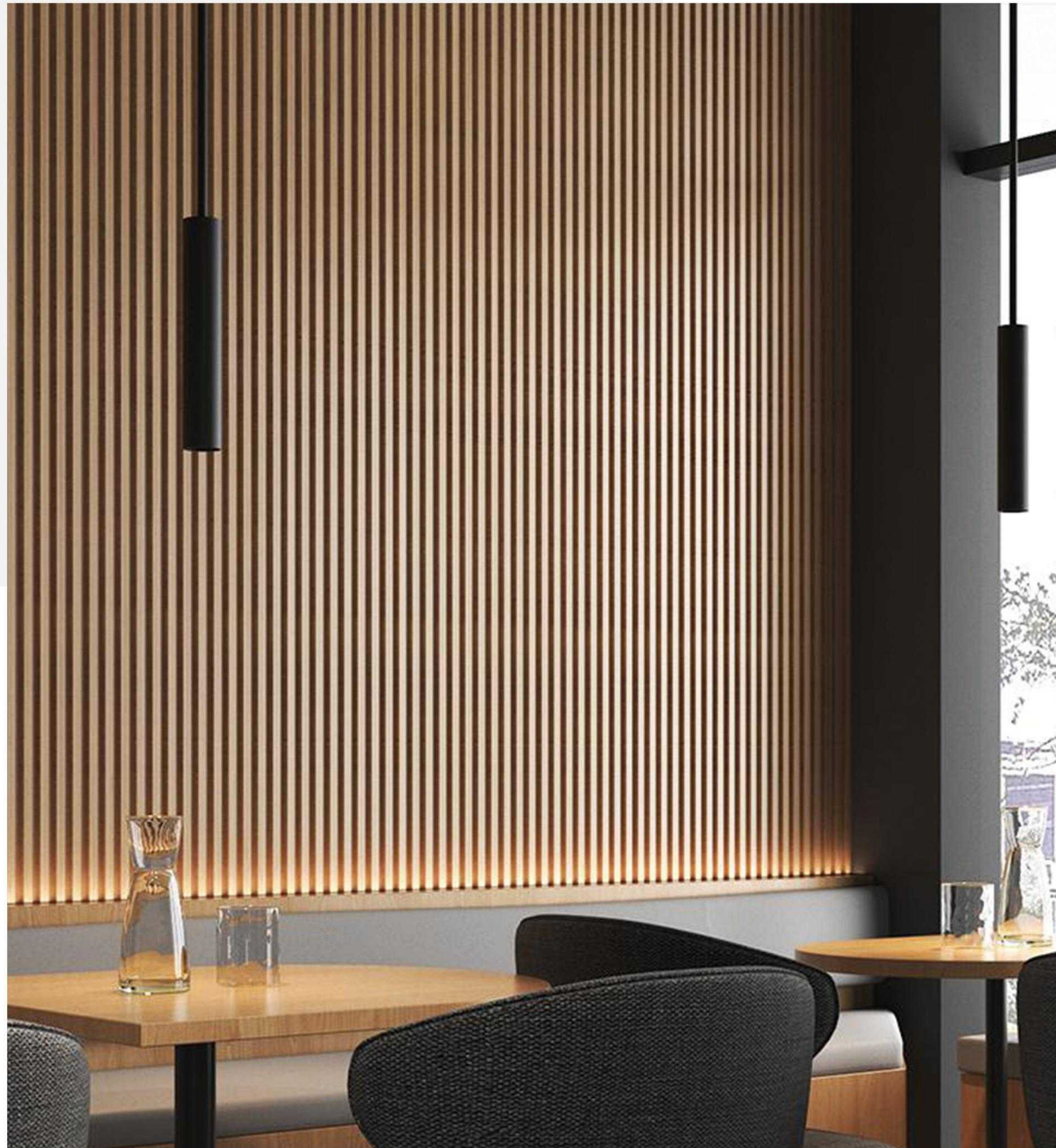



01 WPC Wall Panel  
Hot-selling product series

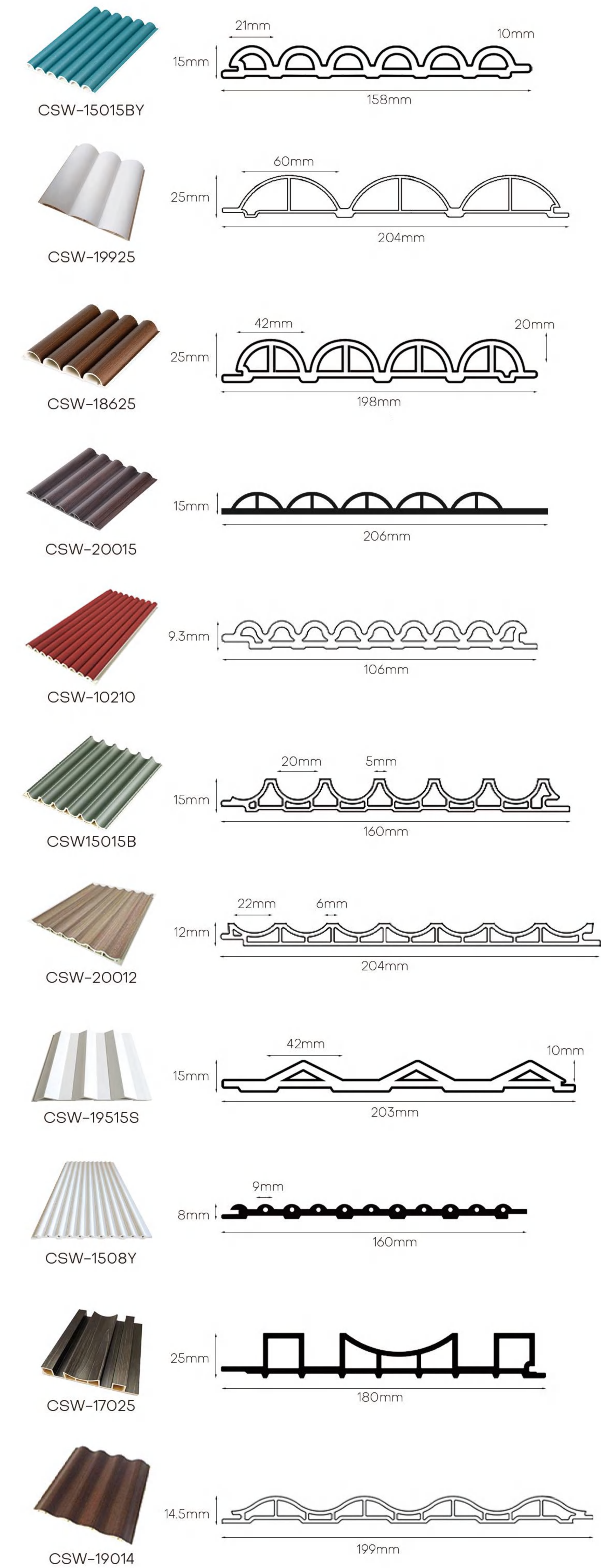



# 01 WPC Wall Panel

Hot-selling product series

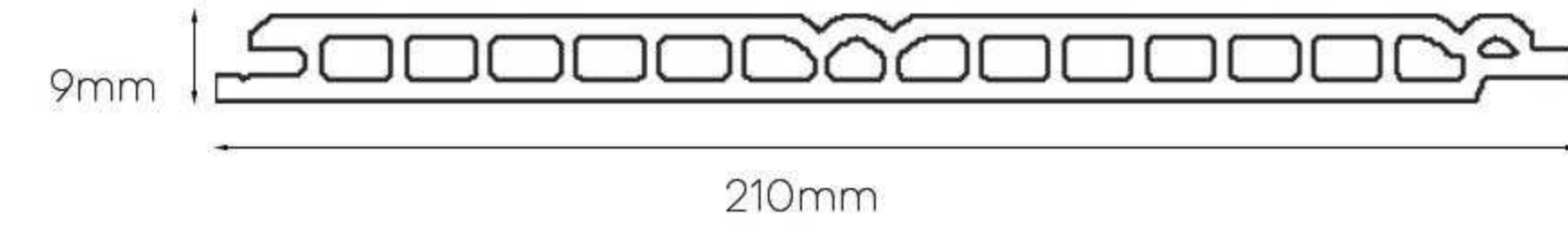
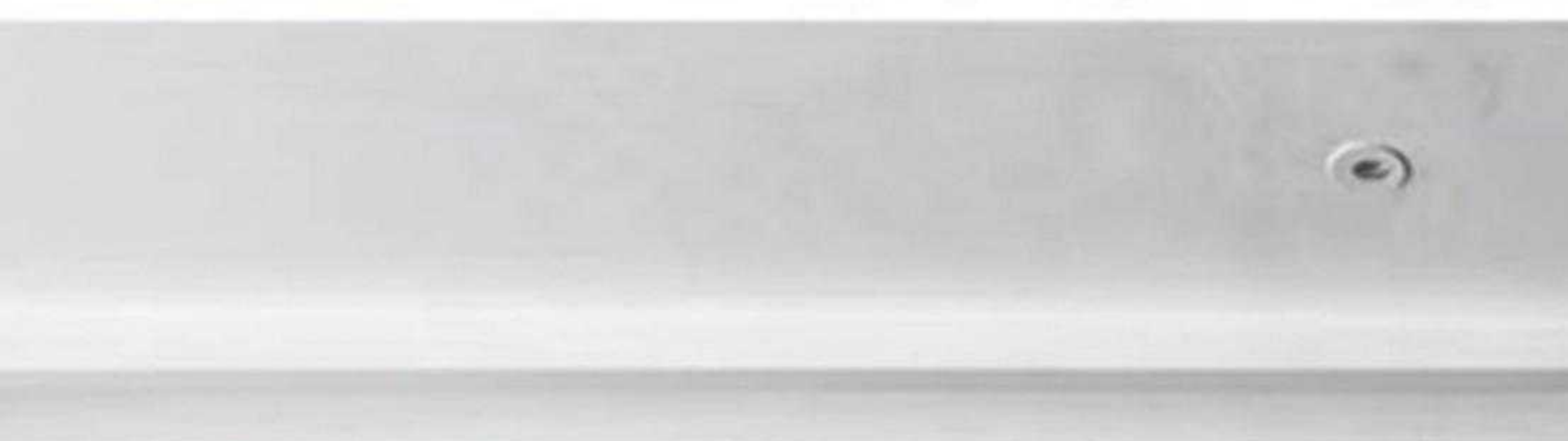

CSW-21009

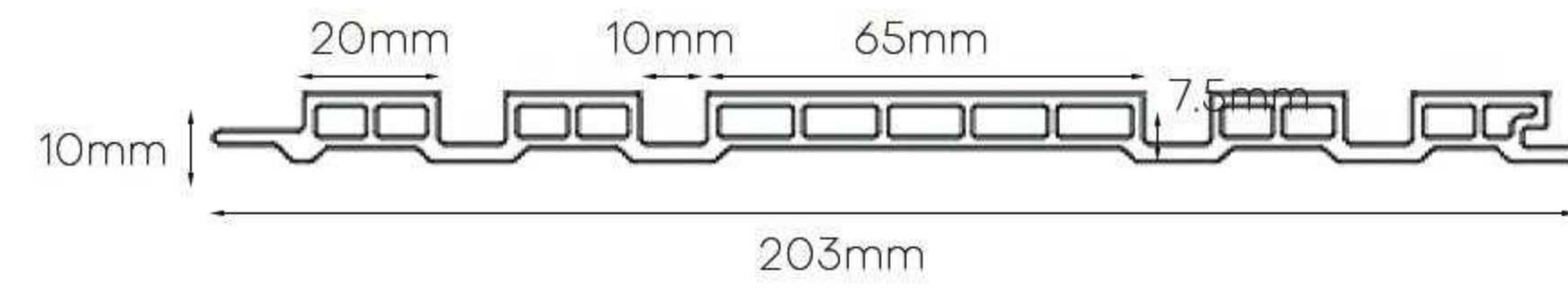

CSW-19610

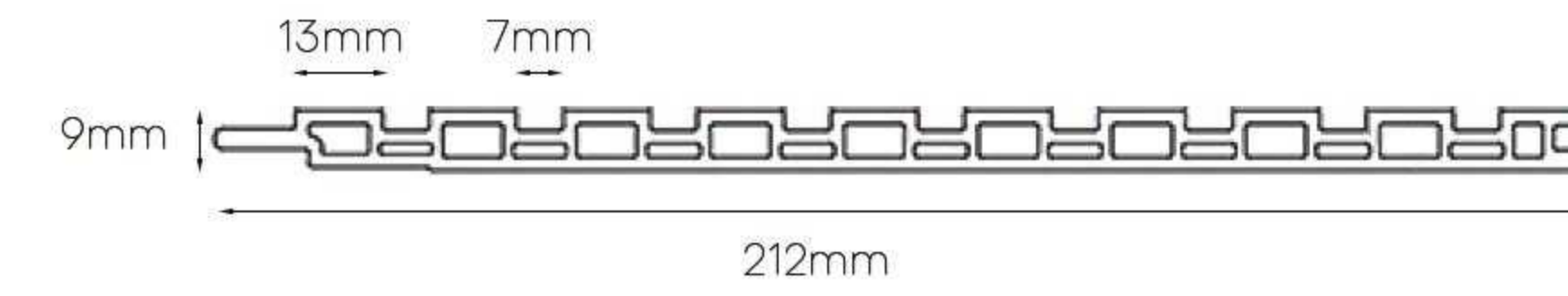

CSW-2059

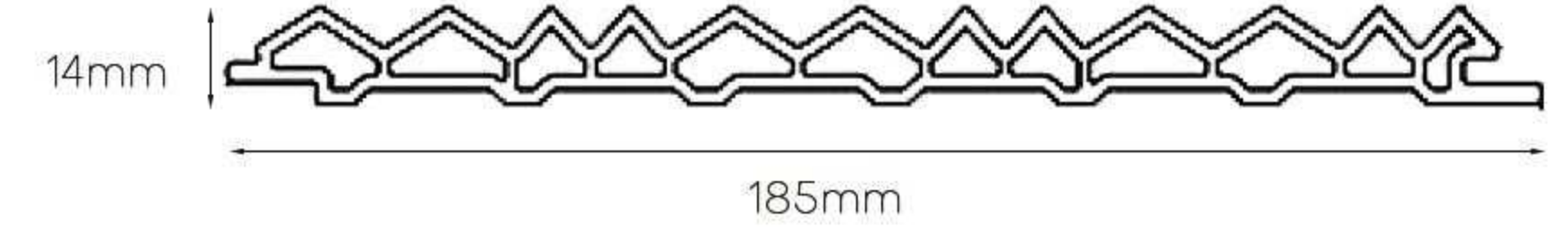

CSW-18014

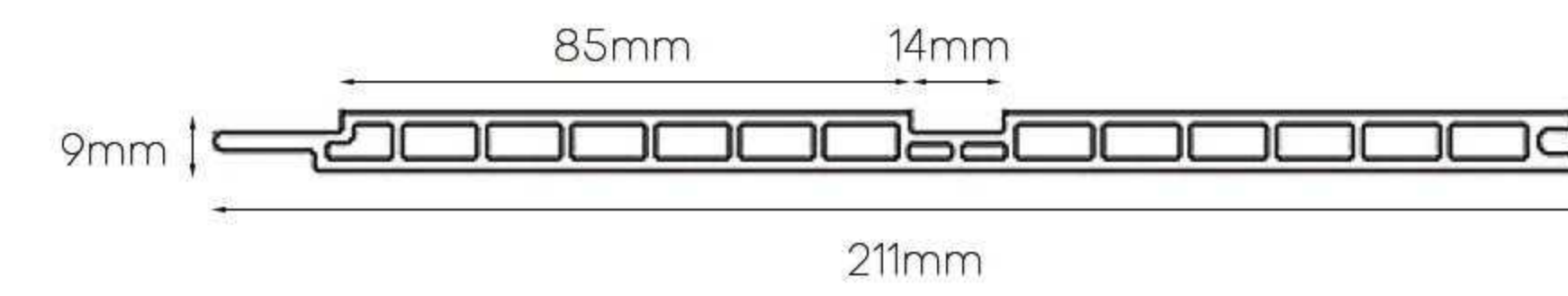

CSW-20010

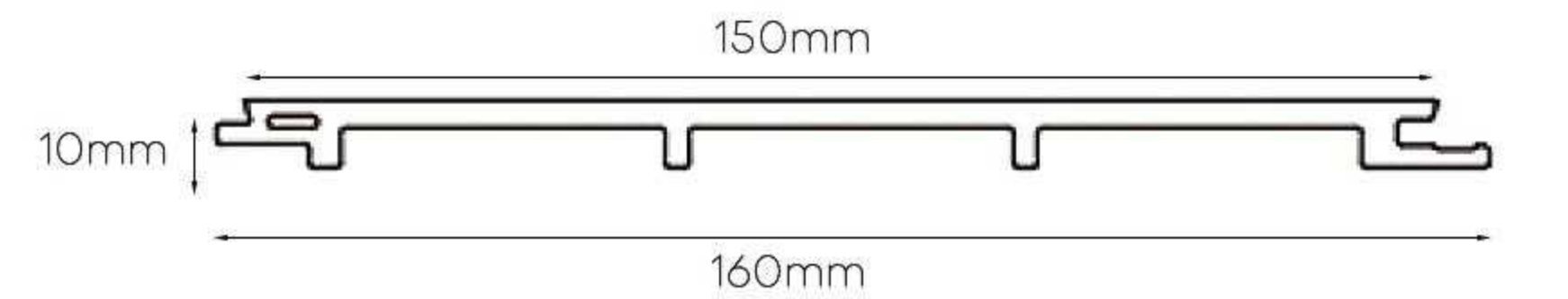

CSW-15010A

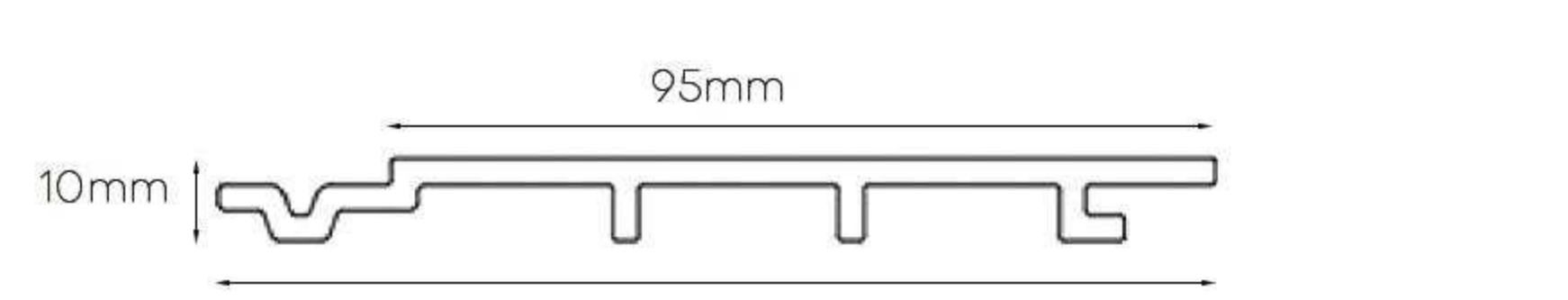

CSW-10210

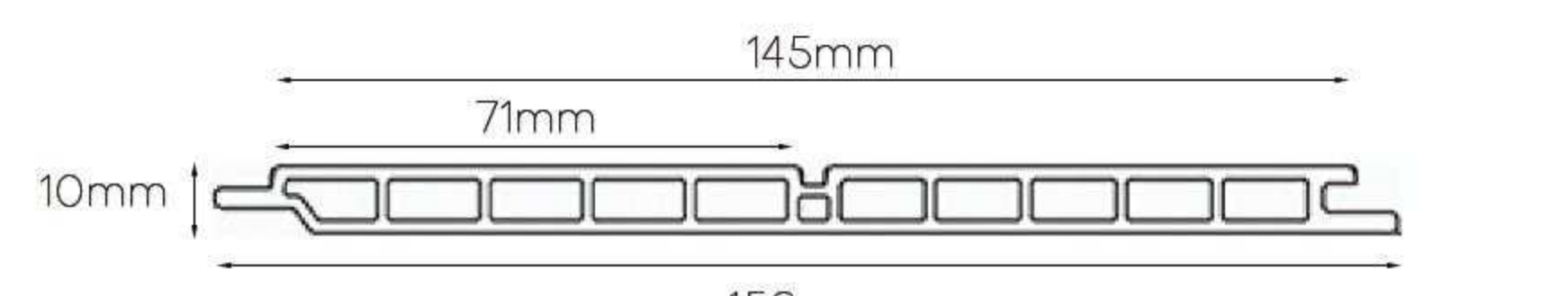

CSW-15010B

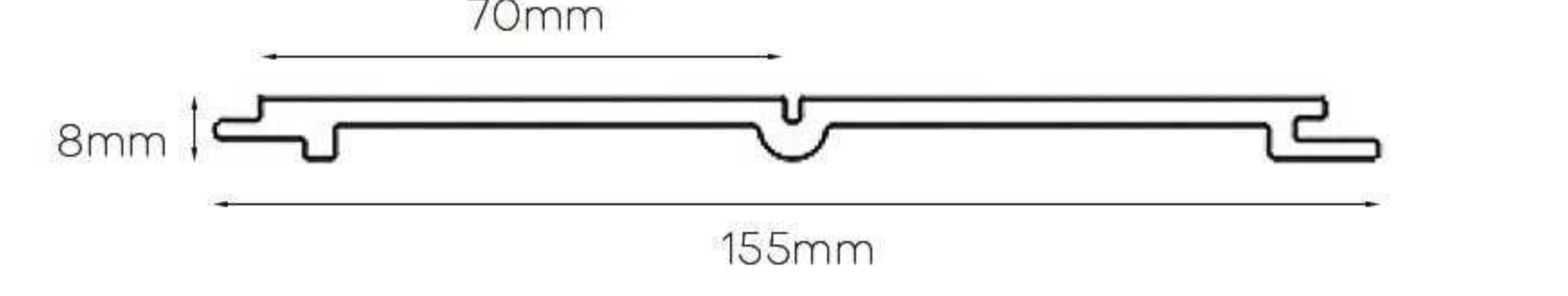

CSW-D75

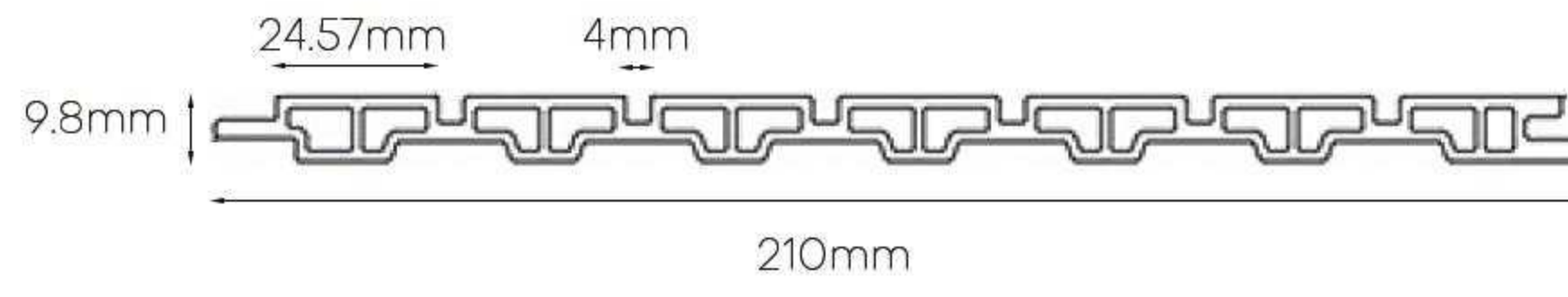

CSW-20010

# 01 WPC Wall Panel

Accessories





# 01 WPC Wall Panel

Installation Method

## • Methods 1



It is better to drive the nail diagonally into the hard surface.  
The nail gun can be covered with another board that plugs in  
It doesn't affect the aesthetics.

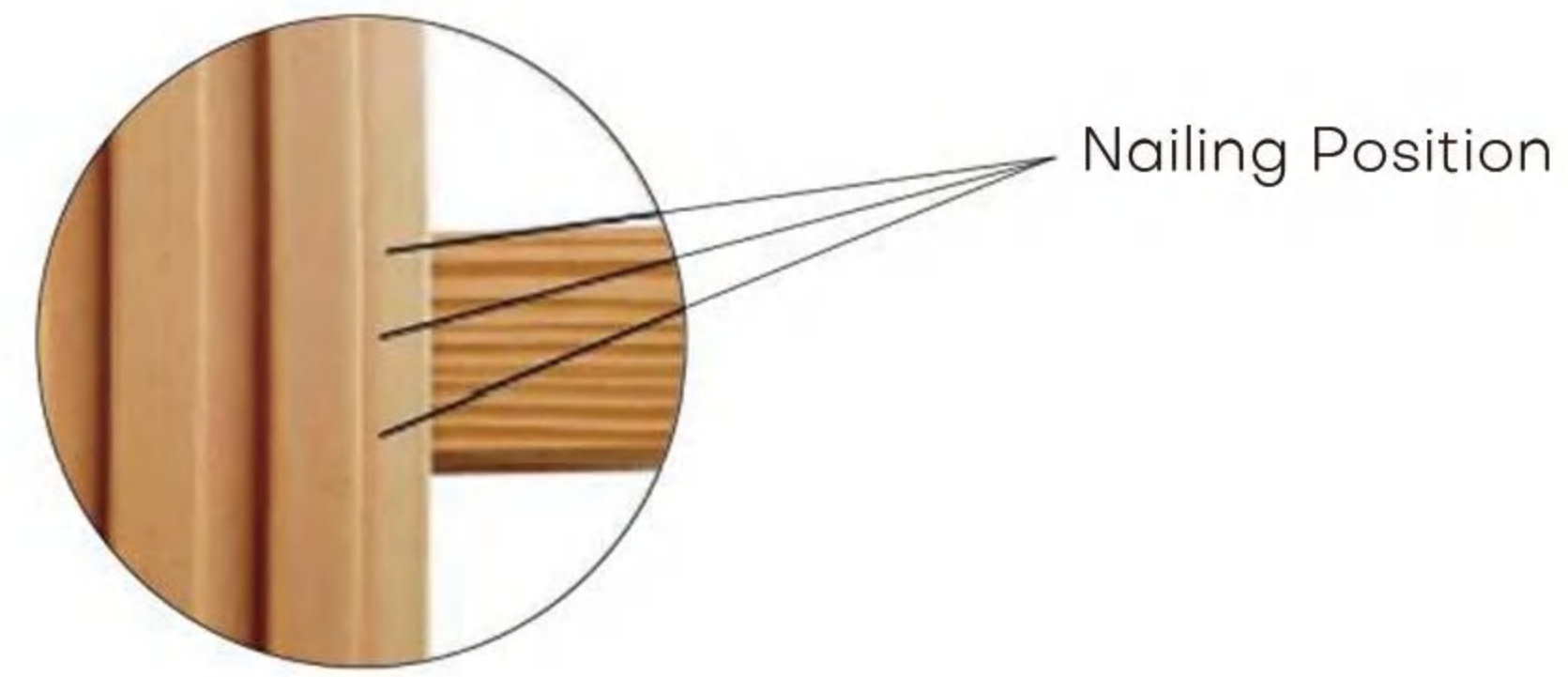

## • Methods 2

Insert the fastener into the bottom edge of the wall panel  
Fixed to the blank wall  
This method applies to the wall with smooth surface wall with a flat surface

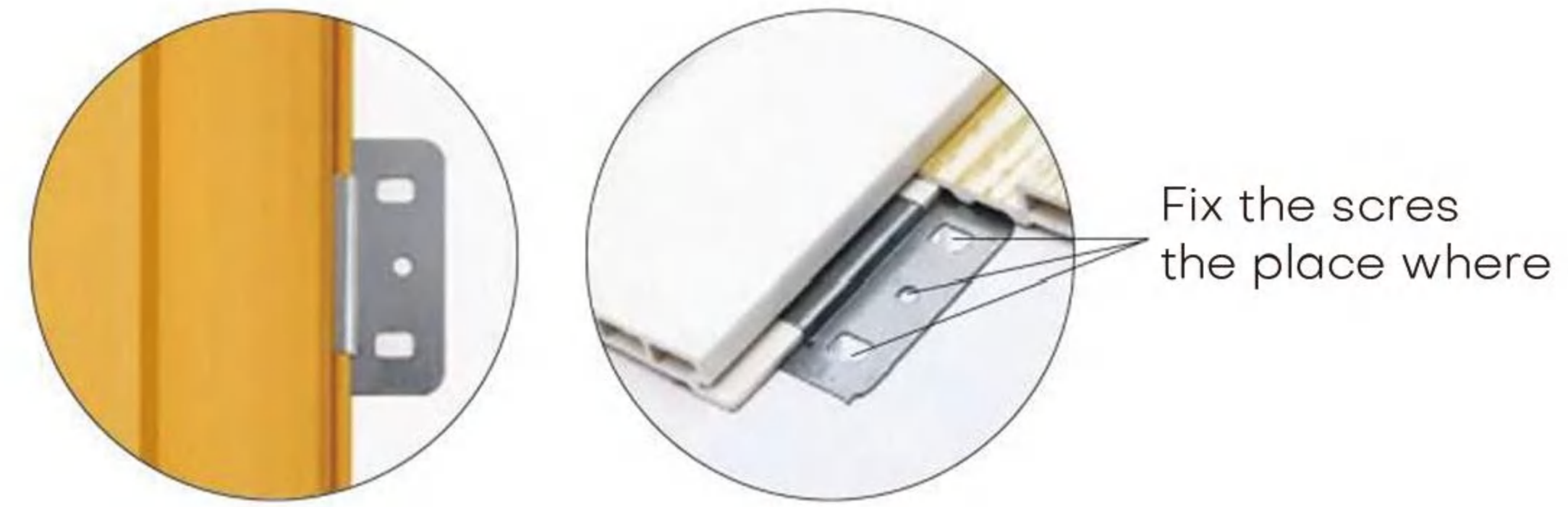

## • Methods 3



Self-trapping screws for stainless steel fasteners  
Fasten to the wooden keel  
This method installs all plates  
It can be disassembled and reused

# 02 WPC Ceiling

Hot-selling product series

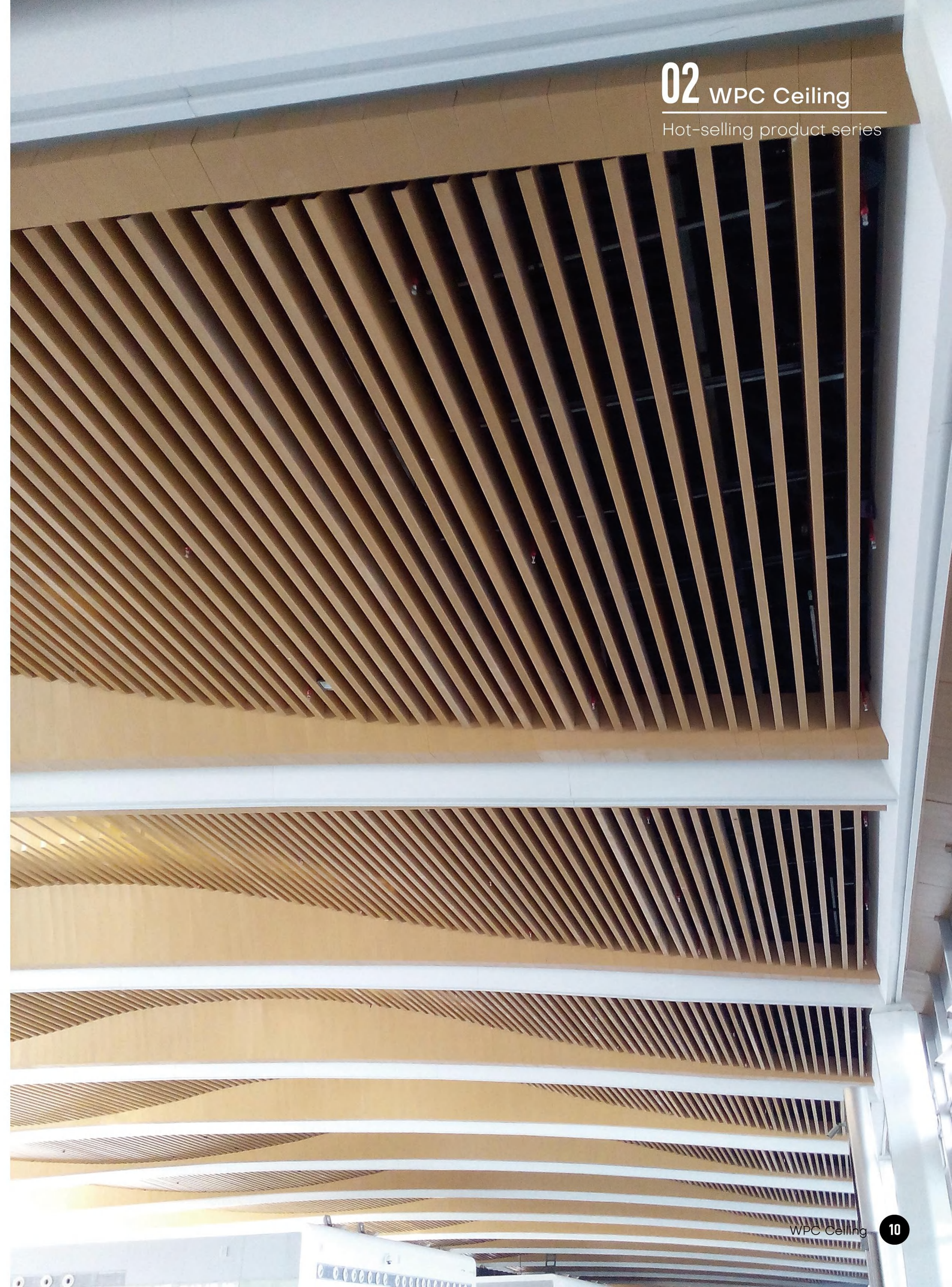



The ecological wood ceiling is a type of ecological wood product, essentially artificial wood. It is a kind of "greener wood plastic composite material," which is a mixture of resin, wood fiber material, and polymer material in specific proportions. Compared to logs, ecological wood has good stability, retains the physical characteristics of solid wood, and is waterproof, anti-corrosive, and provides heat insulation. Modifiers such as light and thermal stability, UV resistance, and low-temperature impact resistance are added during the production of ecological wood, giving it strong weather resistance and UV protection.

**CSW2550**  
 W 25mm  
 H 50mm  
 L 2900mm



**CSW4025**  
 W 40mm  
 H 25mm  
 L 2900mm



**CSW4045**  
 W 40mm  
 H 45mm  
 L 2900mm

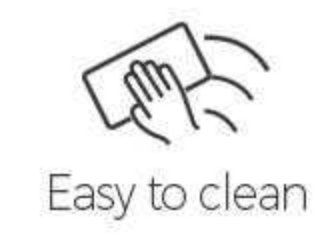

**CSW4060**  
 W 40mm  
 H 60mm  
 L 2900mm



**CSW5060**  
 W 50mm  
 H 60mm  
 L 2900mm

**CSW4075**  
 W 40mm  
 H 75mm  
 L 2900mm

**CSW5075**  
 W 50mm  
 H 75mm  
 L 2900mm

**CSW4080**  
 W 40mm  
 H 80mm  
 L 2900mm

**CSW5090**  
 W 50mm  
 H 90mm  
 L 2900mm

**CSW40100**  
 W 40mm  
 H 100mm  
 L 2900mm

**CSW50100**  
 W 50mm  
 H 100mm  
 L 2900mm

## Accessories



Keel



Hanger

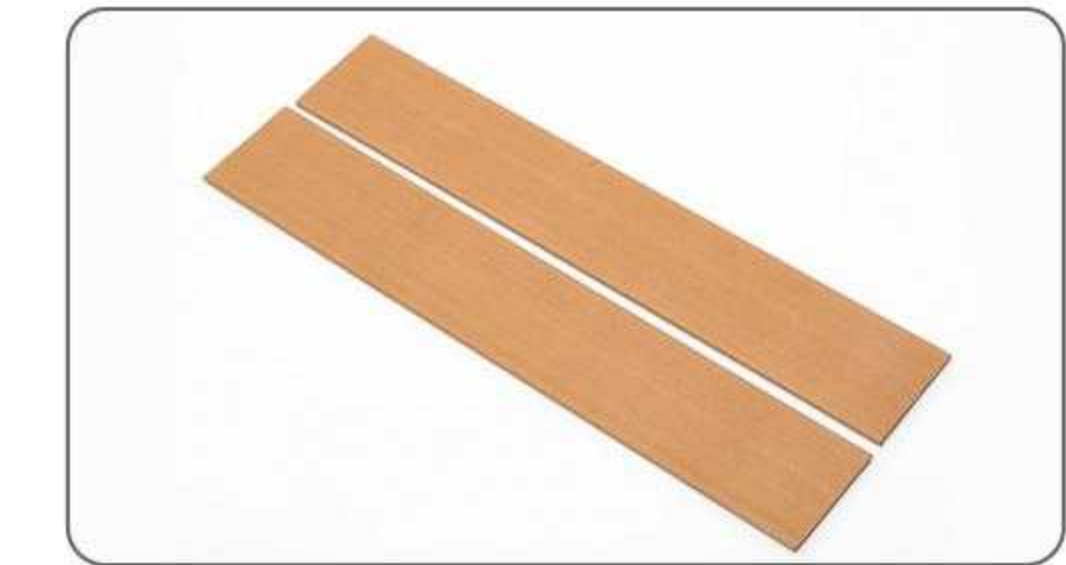

Shutter

## Installation structure

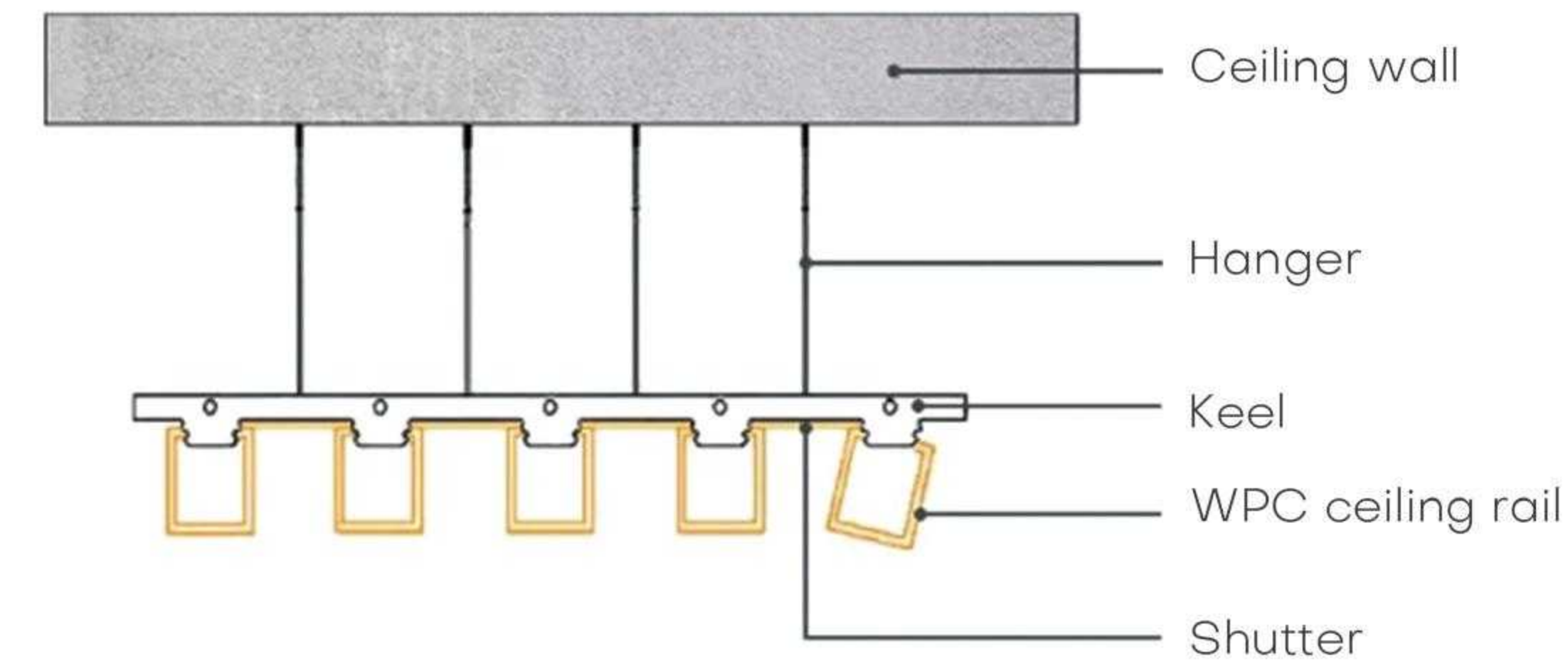

## Installation

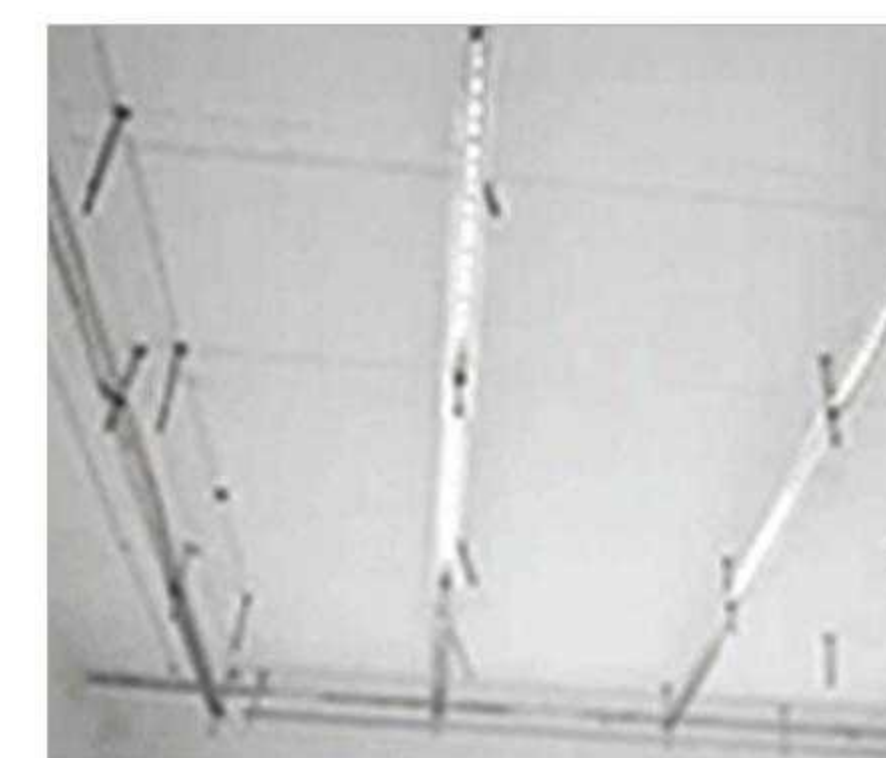

Positioning and punching



Install hangers



Fixed keel



Install the ceiling on the keel



# 03 WPC Timber Tube

Hot-selling product series

WPC (Wood Plastic Composite) timber tubes are composite materials made from a blend of wood fibers or wood flour and thermoplastics, typically polyethylene, polypropylene, or PVC. This combination results in a product that mimics the appearance of natural wood while providing the benefits of plastic, such as enhanced durability and resistance to environmental factors.



### CSW4025

W 40mm  
H 25mm  
L 2900mm

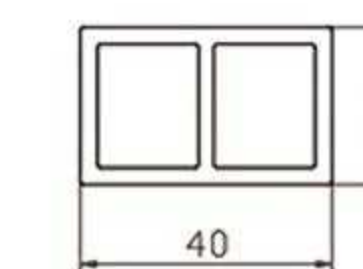
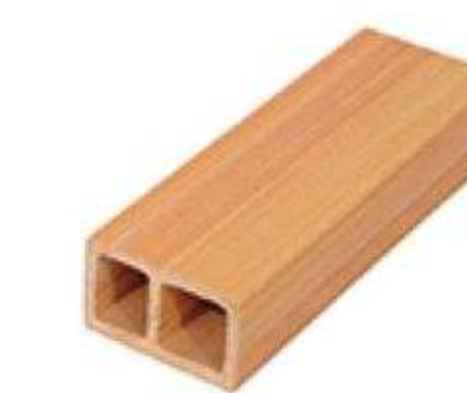

### CSW7550

W 75mm  
H 50mm  
L 2900mm

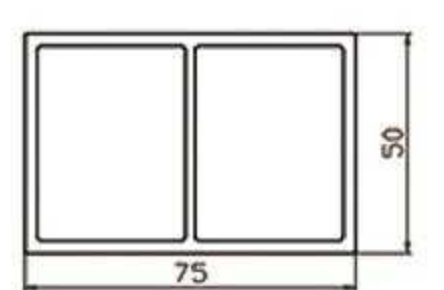

### CSW5025

W 50mm  
H 25mm  
L 2900mm

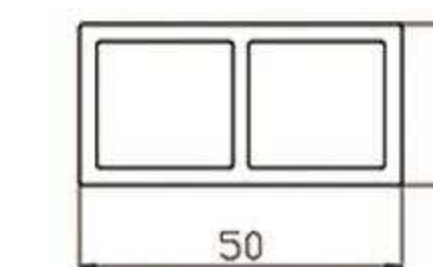

### CSW10050

W 100mm  
H 50mm  
L 2900mm

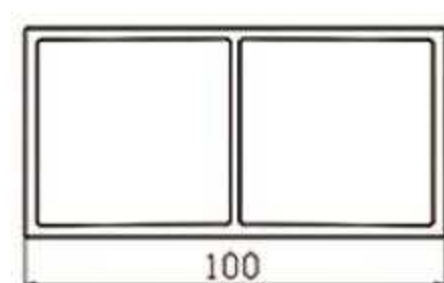

### CSW5040

W 50mm  
H 40mm  
L 2900mm

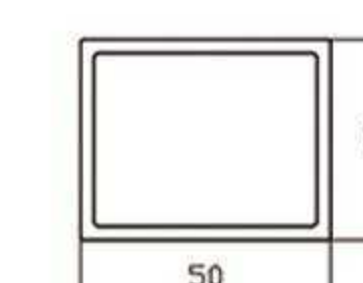

### CSW10050

W 100mm  
H 50mm  
L 2900mm

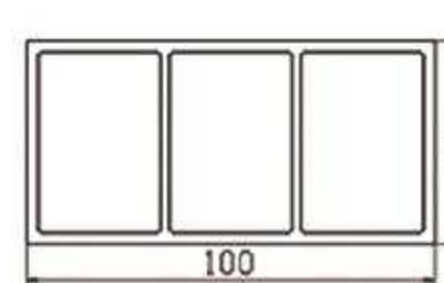

### CSW5050

W 50mm  
H 50mm  
L 2900mm

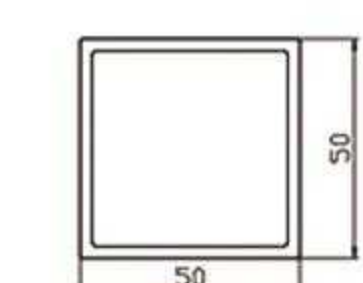

### CSW100100

W 100mm  
H 100mm  
L 2900mm

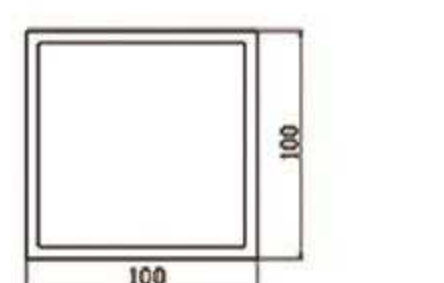

### CSW6525

W 65mm  
H 25mm  
L 2900mm

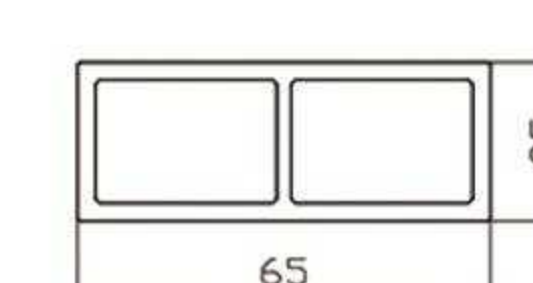

### CSW15050

W 150mm  
H 50mm  
L 2900mm

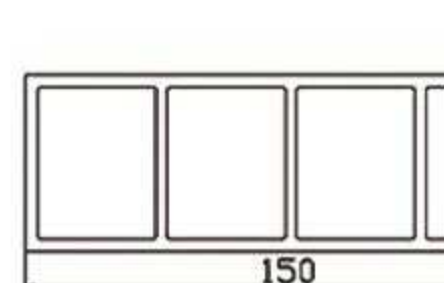



# 03 WPC Timber Tube

Installation Method

## Installation



1.Clean both ends of WPC timber tube and put glue in.

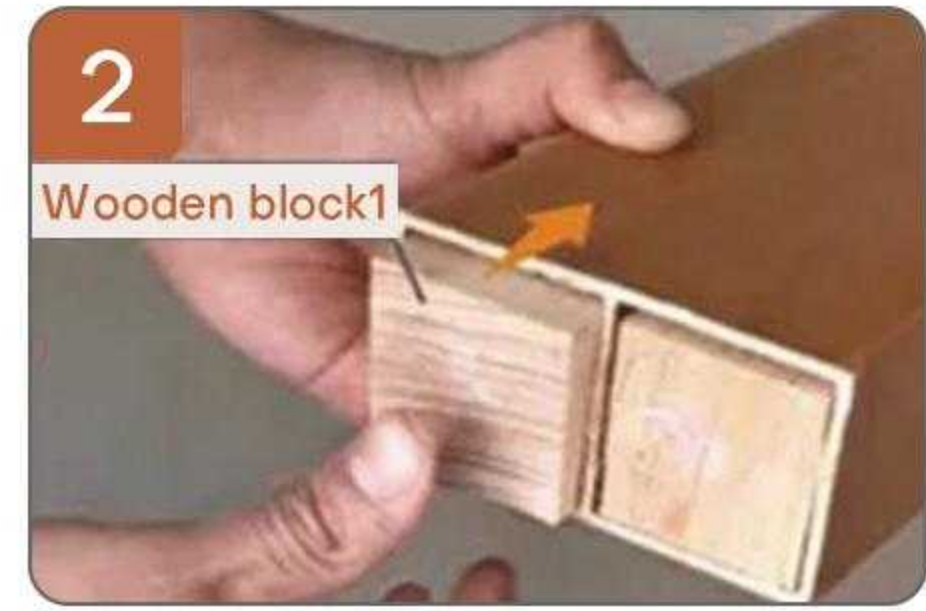
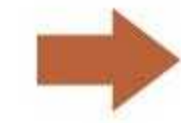

2.Insert the wooden block 1 which is 5cm in both ends of WPC timber tube.

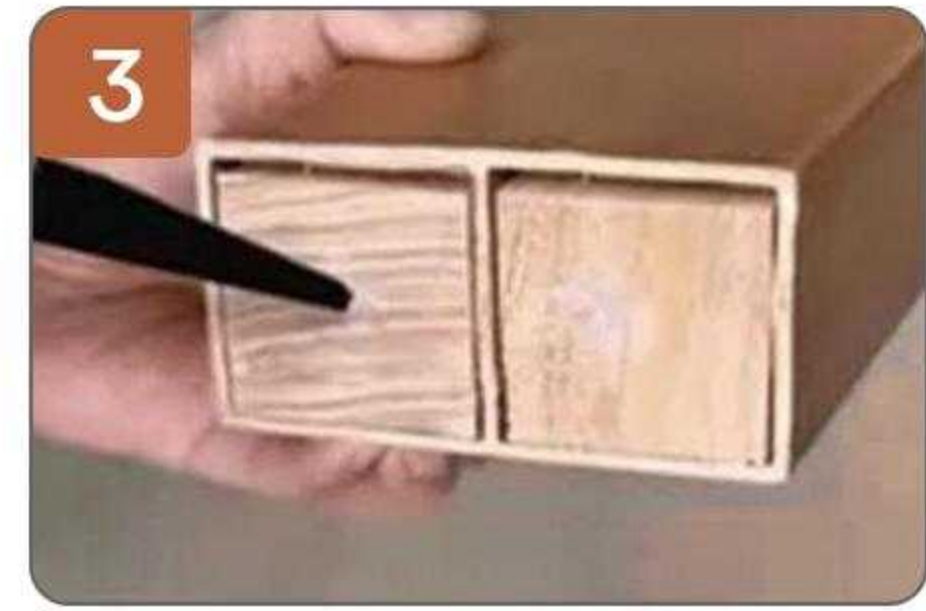

3.Put glue on both ends of the wooden block 1 for WPC timber tube.



4.Fix wooden block 2 on position of the ceiling floor by glue, and then put the WPC square tube on the position of wooden block 2, then finish.

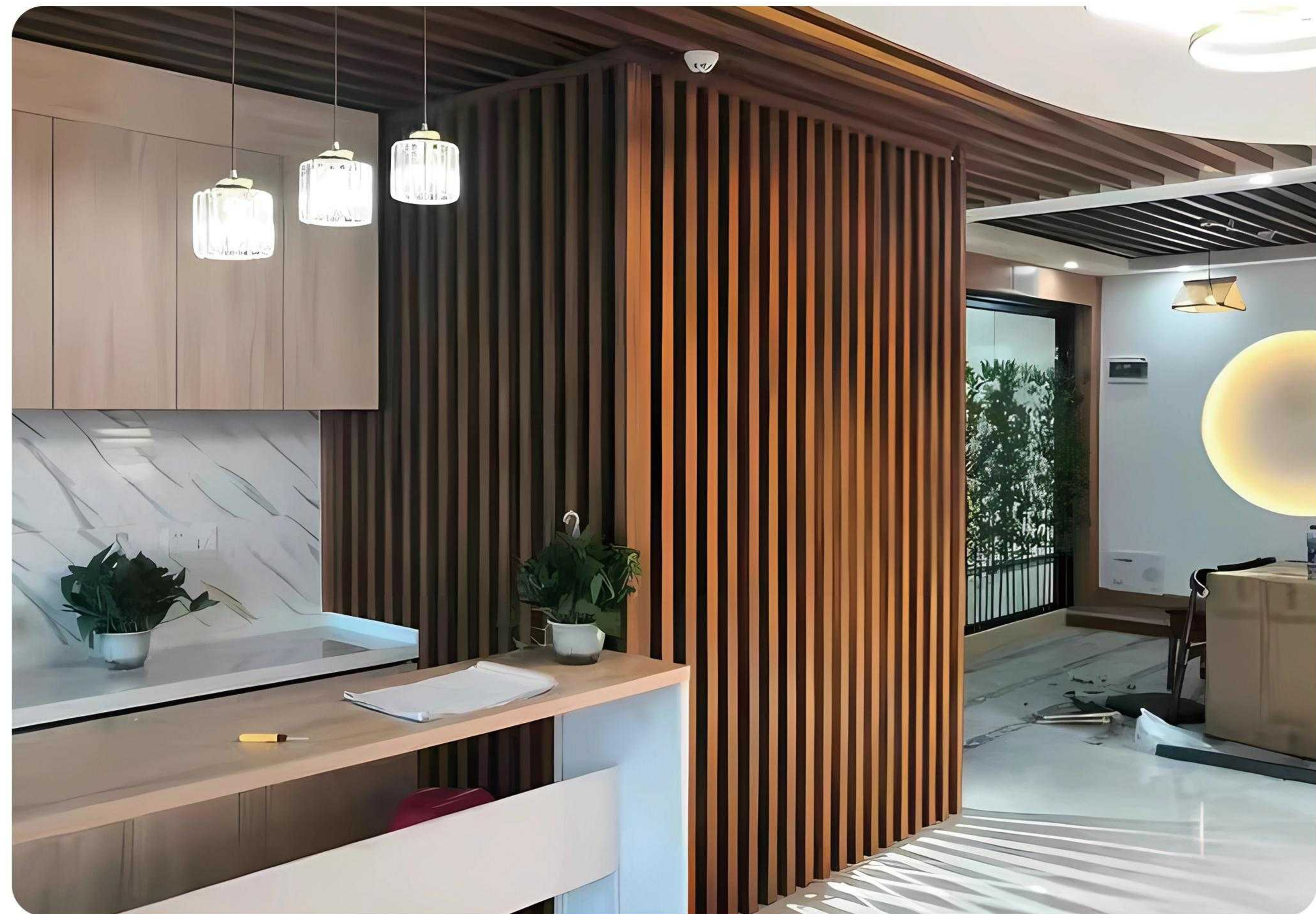

# 04 Bamboo Charcoal Wood Veneer

Hot-selling product series





# 04 Bamboo Charcoal Wood Veneer

Hot-selling product series

Bamboo Charcoal Wood Veneer is made of polyvinyl chloride resin, combined with wood powder and special additives, then extruded. It is a waterproof, lightweight, expanded rigid plastic board suitable for various applications, including kitchen and bathroom cabinets, interior decoration, booths, advertising signs and displays, prototypes, and more.

Due to its high workability, Bamboo Charcoal Wood Veneer can be easily processed by sawing, CNC cutting, printing, sanding, routing, painting, laminating, and other methods.



## Splicing method



Flat Seam Channel U-shaped Channel Double Female Channel

## Bendable and chamferable

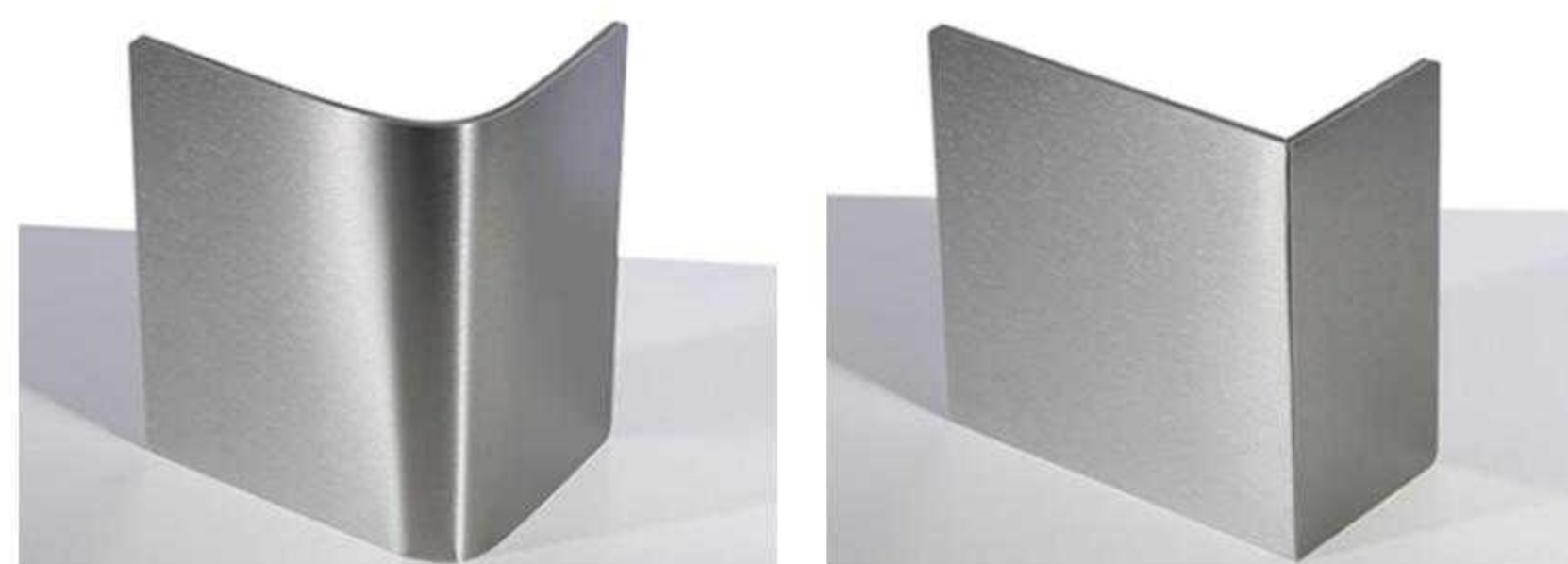

## Matching lines

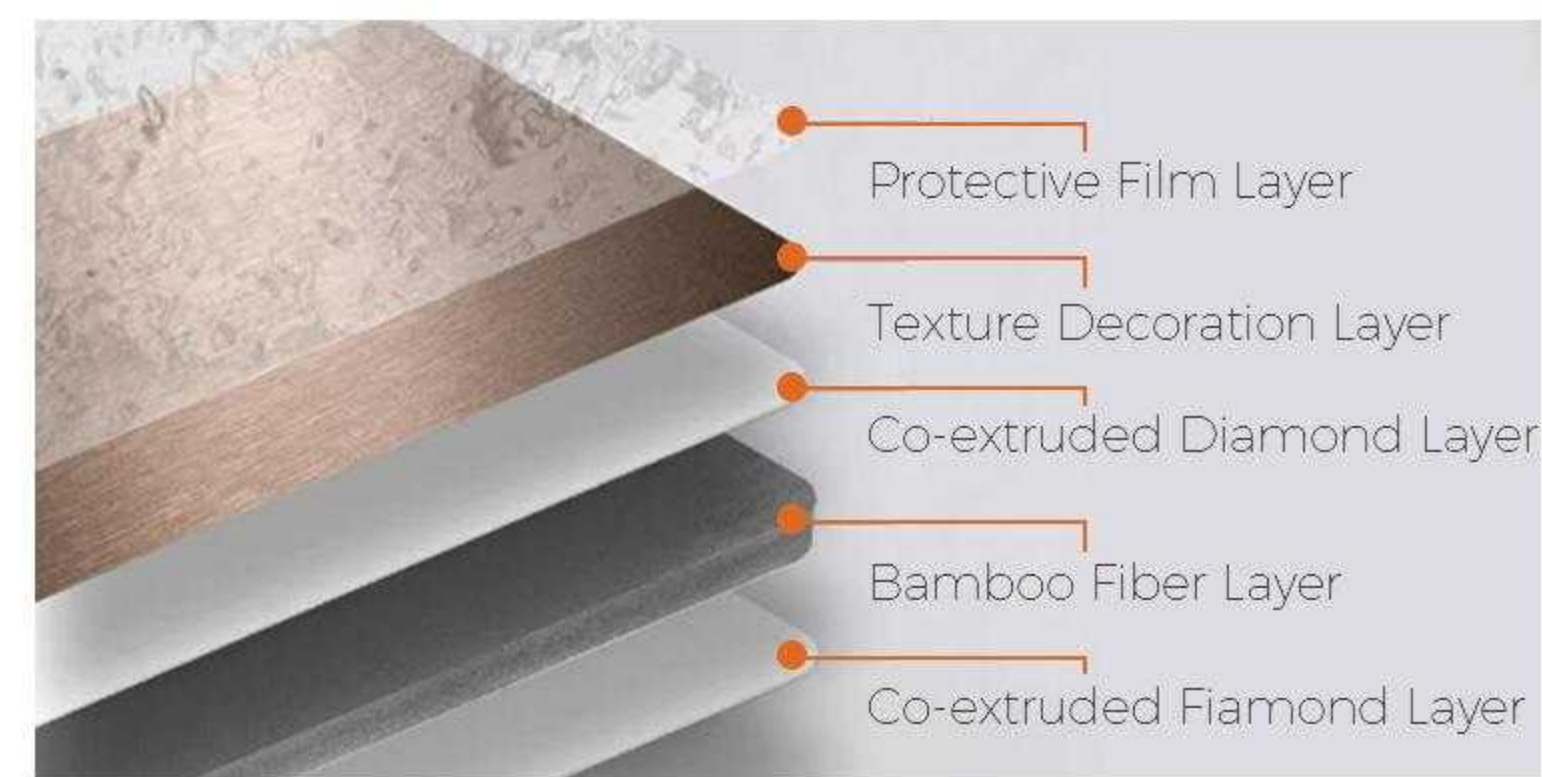
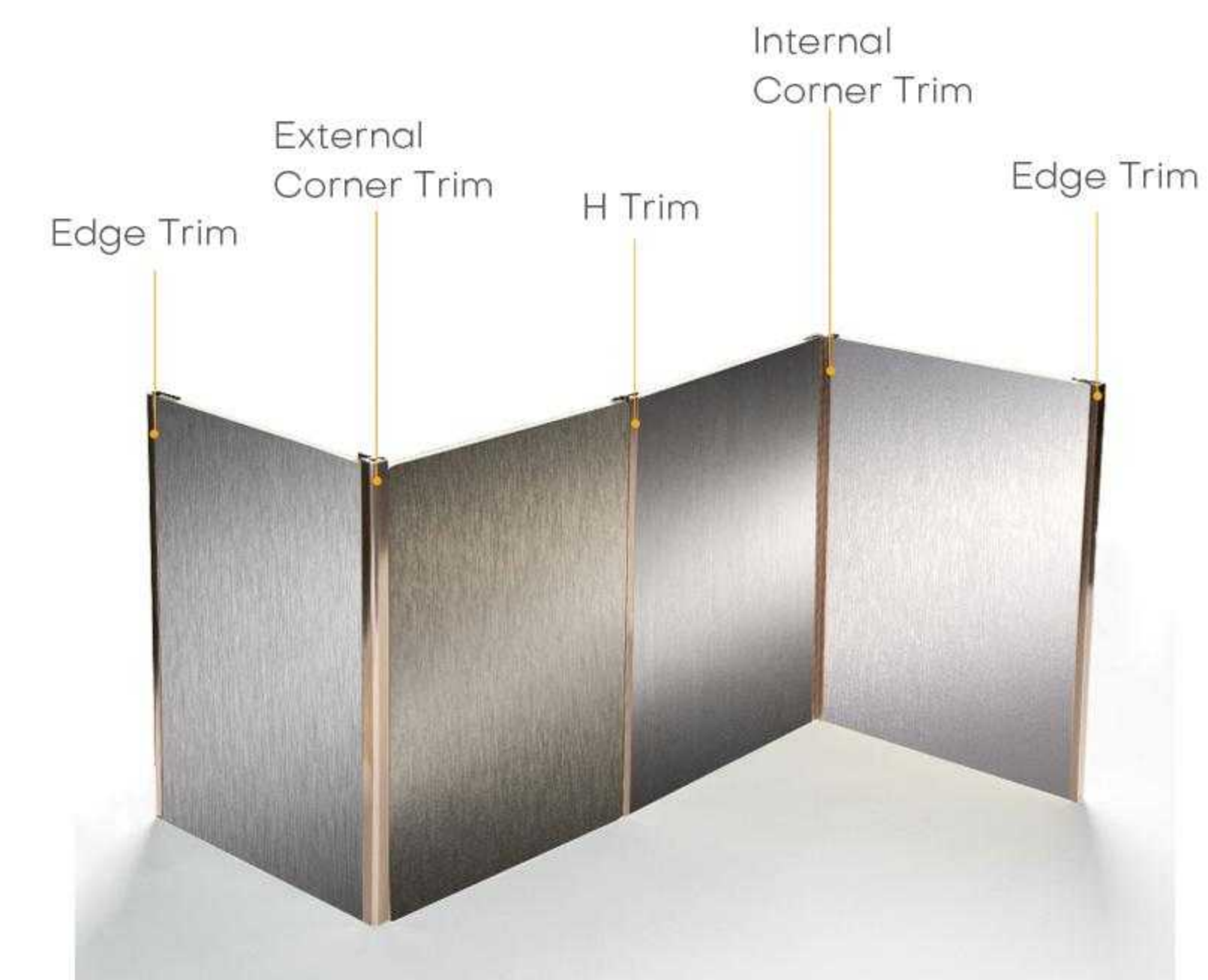

Material	Wood plastic composite
Thickness	5/8mm
Size	1220*2440mm(4*8feet),customized
Processing Service	Cutting,Curving,Packing,etc.
Density	0.5-0.9tons/m <sup>3</sup>
Colour	Wooden Color
Applications	Living room, bedroom, restaurant, hotel, entertainment venue, resort, etc. Indoor wall, ceiling.

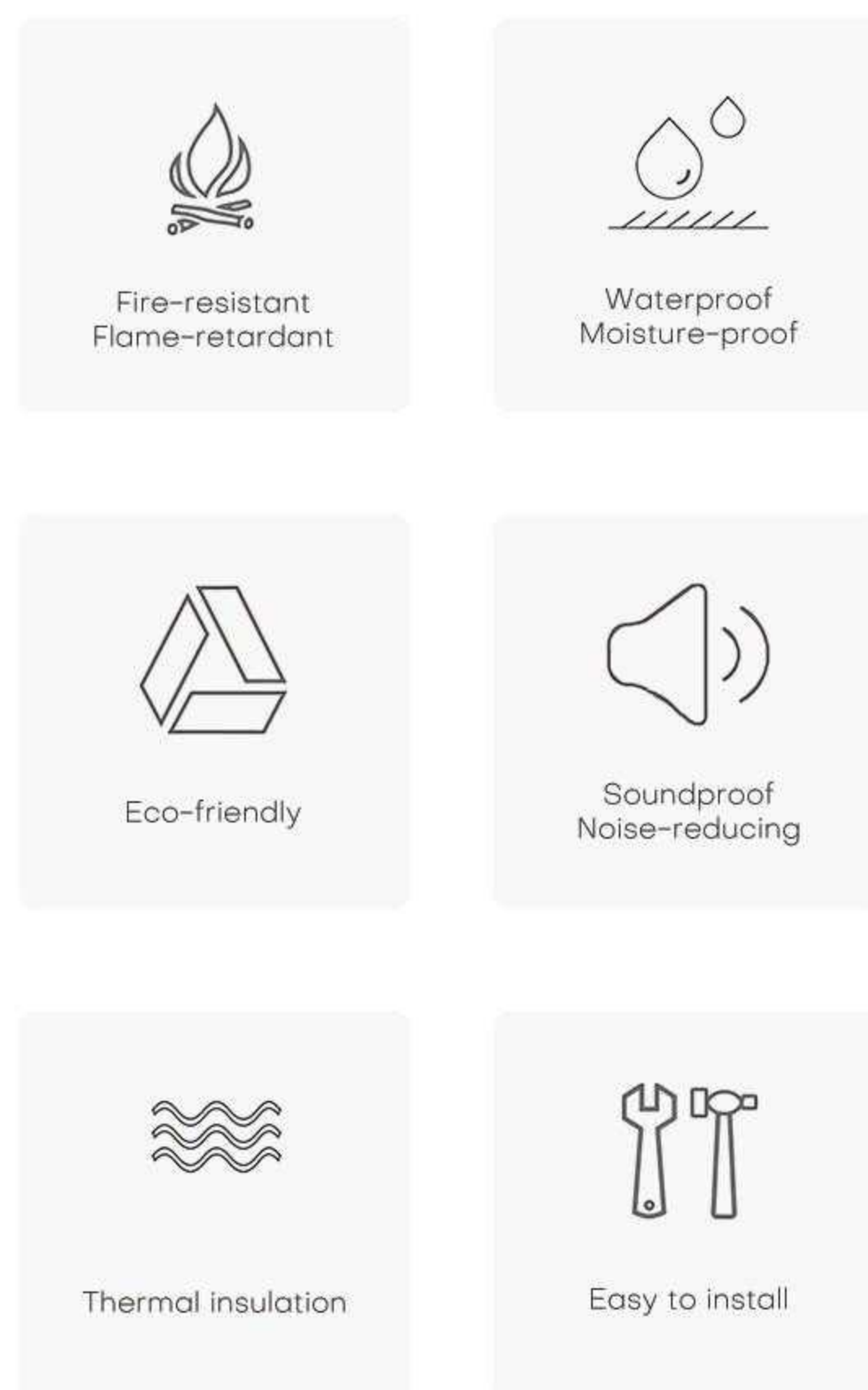

PVC Film



L-001 L-002 L-003 L-004



L-005 L-006 L-007 L-008

Continuous PET Pattern



H-001



H-002

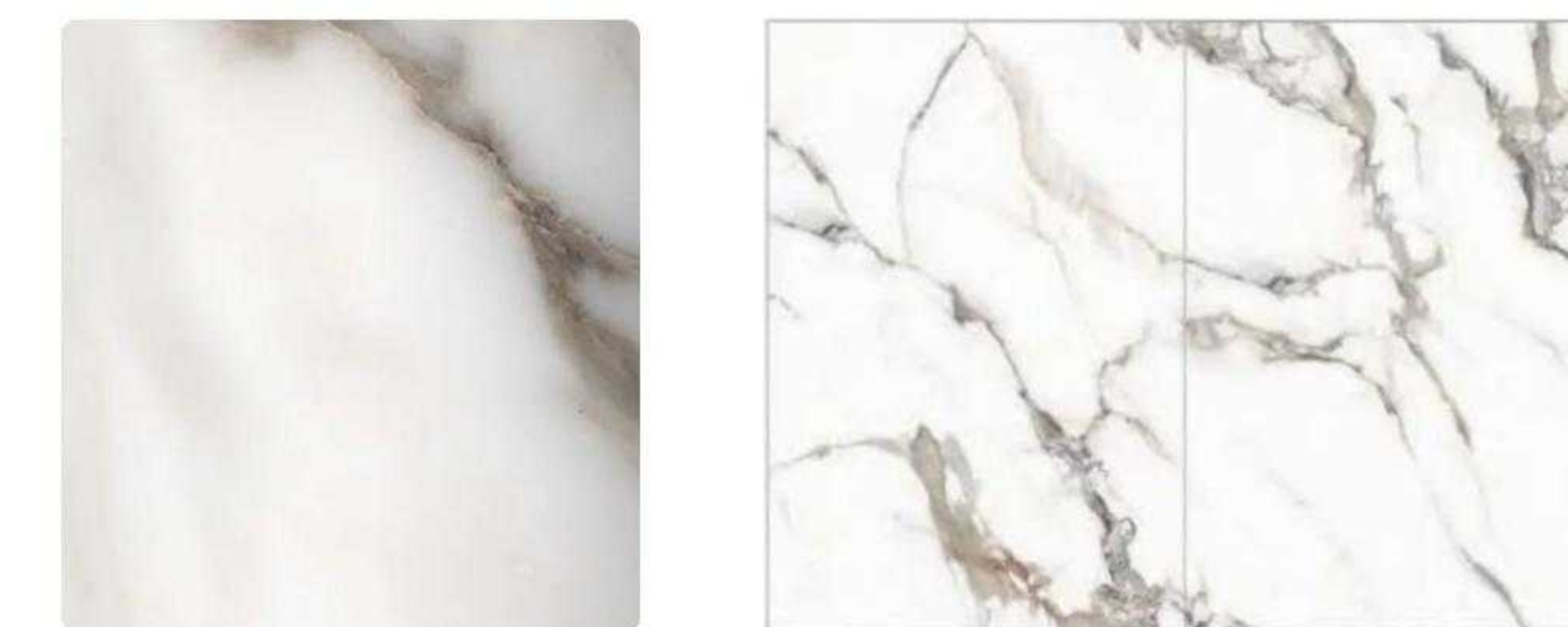

H-003



H-004



# 04 Bamboo Charcoal Wood Veneer

Hot-selling product series

Skin Feel

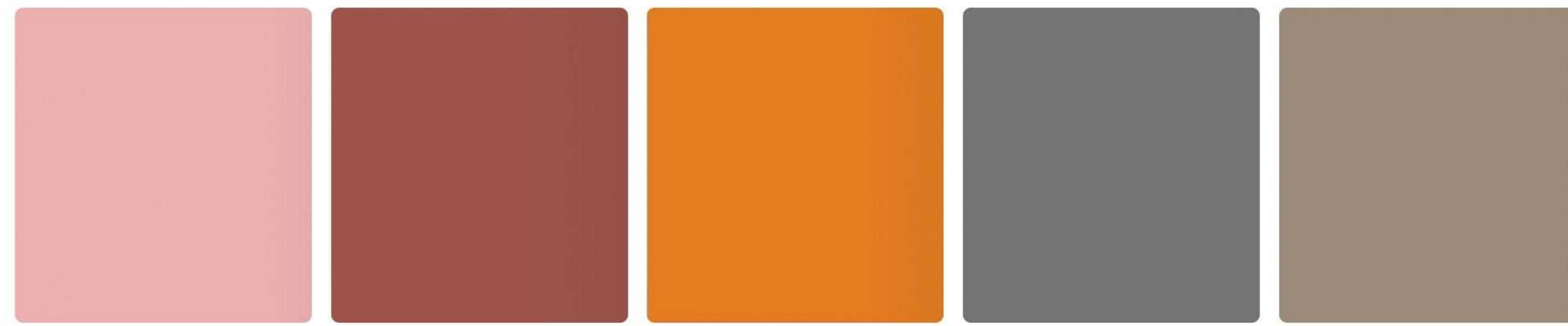

S-001      S-002      S-003      S-004      H-101

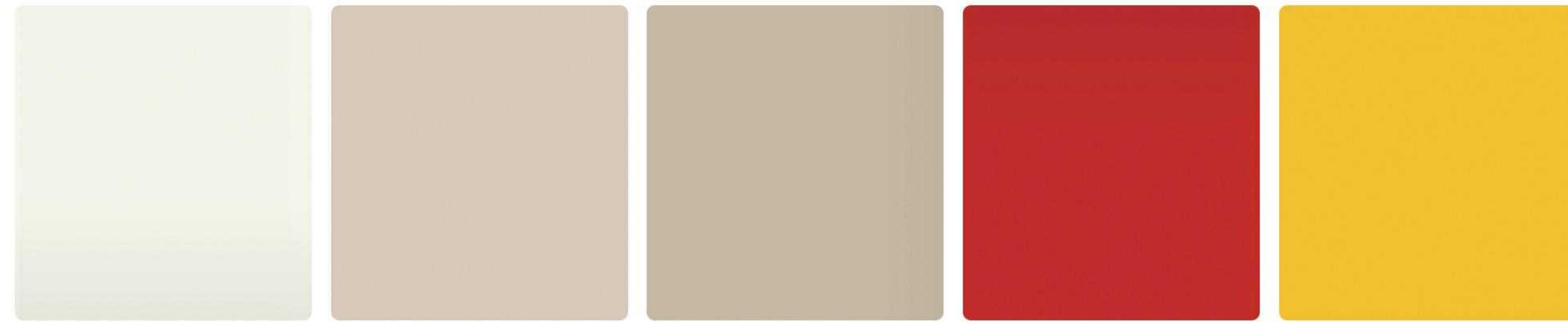

H-102      H-103      H-104      H-105      H-106

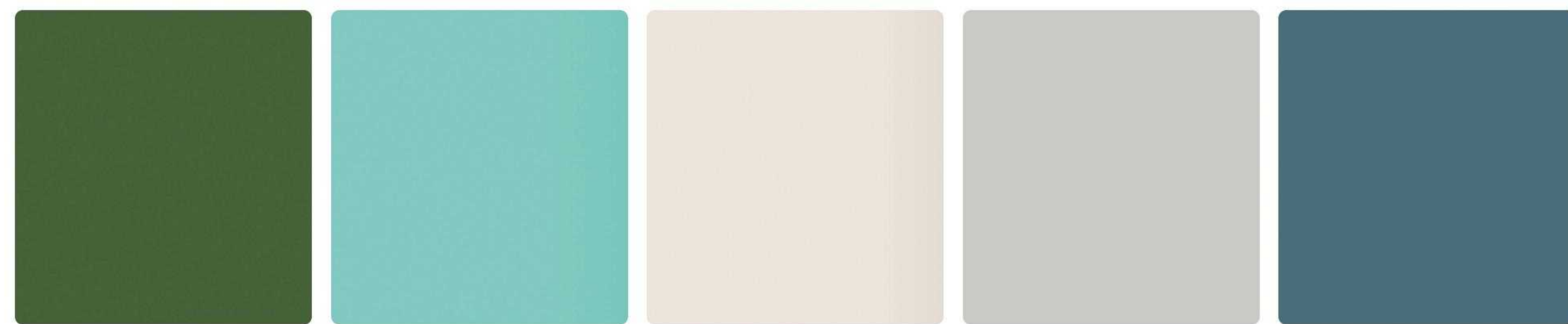

H-107      H-108      R-001      R-002      R-003

Baby's Breath

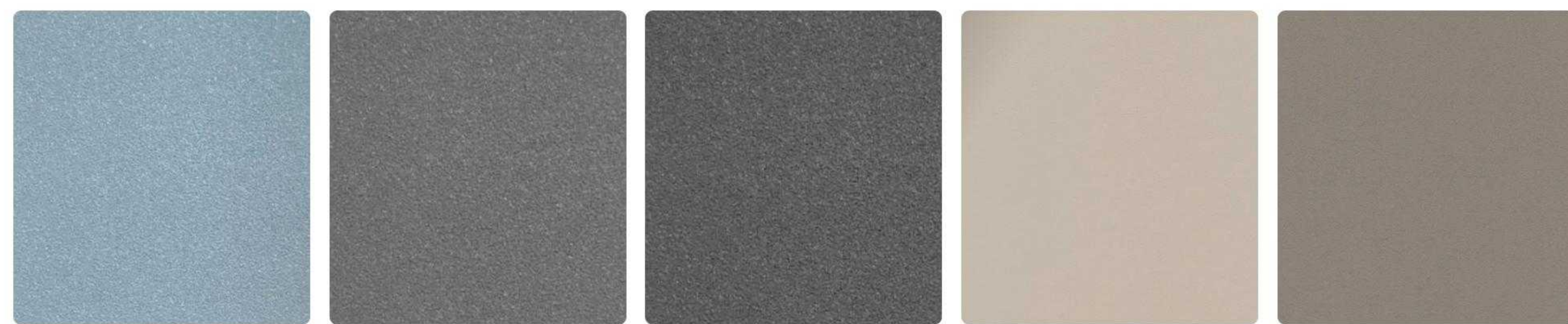

S-101      S-102      S-103      H-201      H-202



H-203      H-204      H-205      H-206      H-207

Metal Wire-Drawing

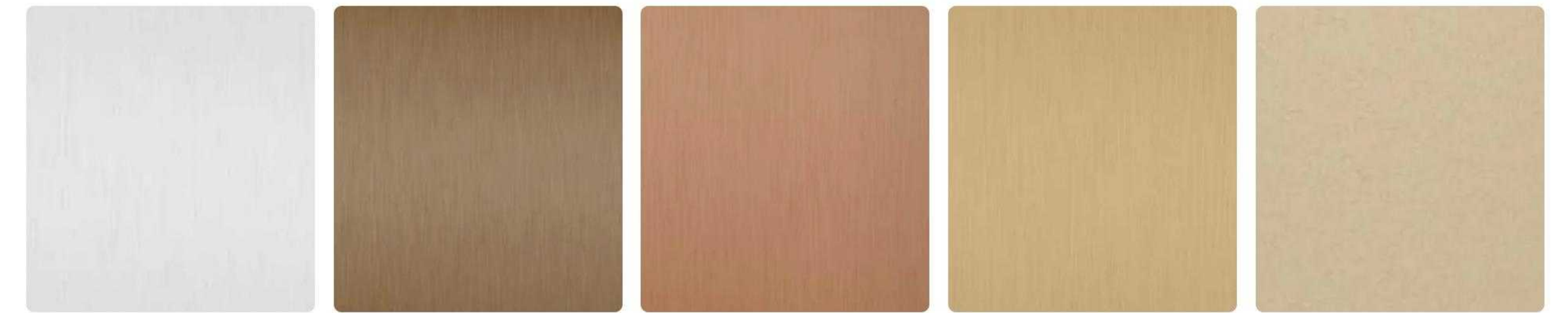

H-301      H-302      H-303      H-304      H-305



H-306      H-307      H-308      H-309      H-310

Mirror



S-201      S-202      S-203      S-204      S-205



S-206      S-207

Water Ripple





# 04 Bamboo Charcoal Wood Veneer

Hot-selling product series

Color Focus

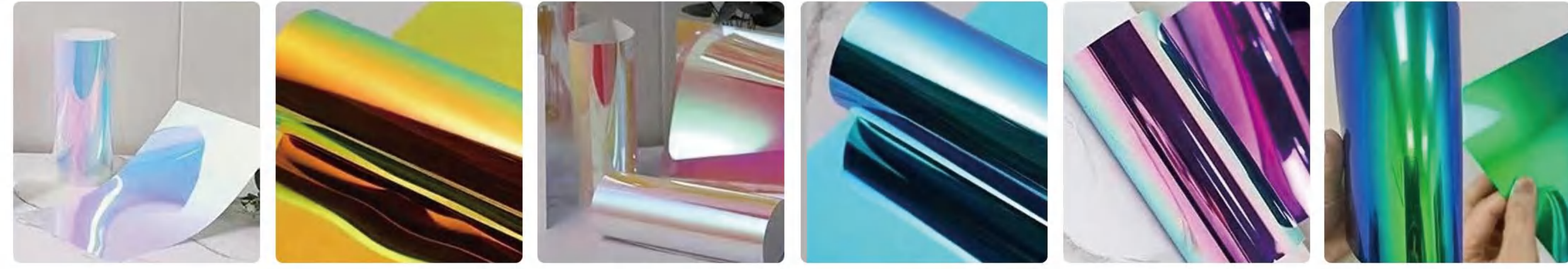

L-101 L-102 L-103 L-104 L-105 L-106

Laser

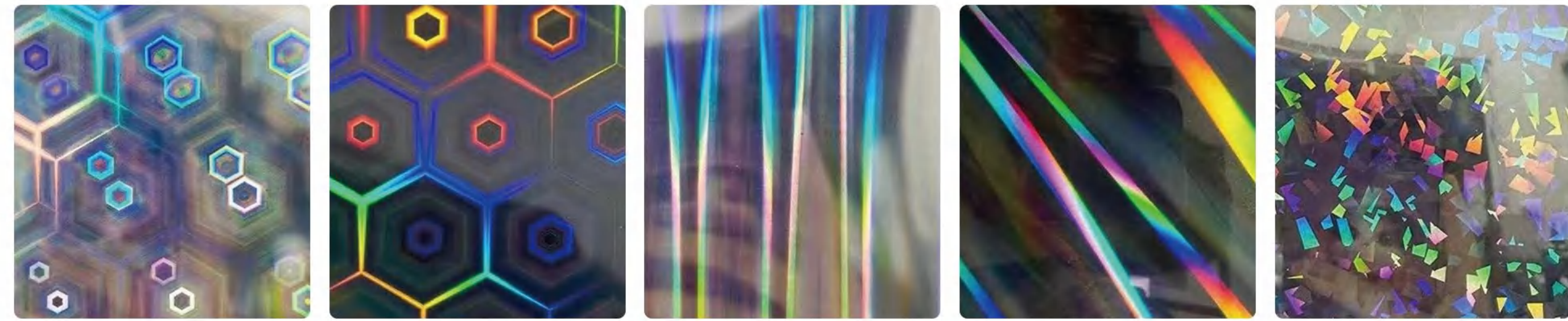

L-201 L-202 L-203 L-204 L-205

Mosaic

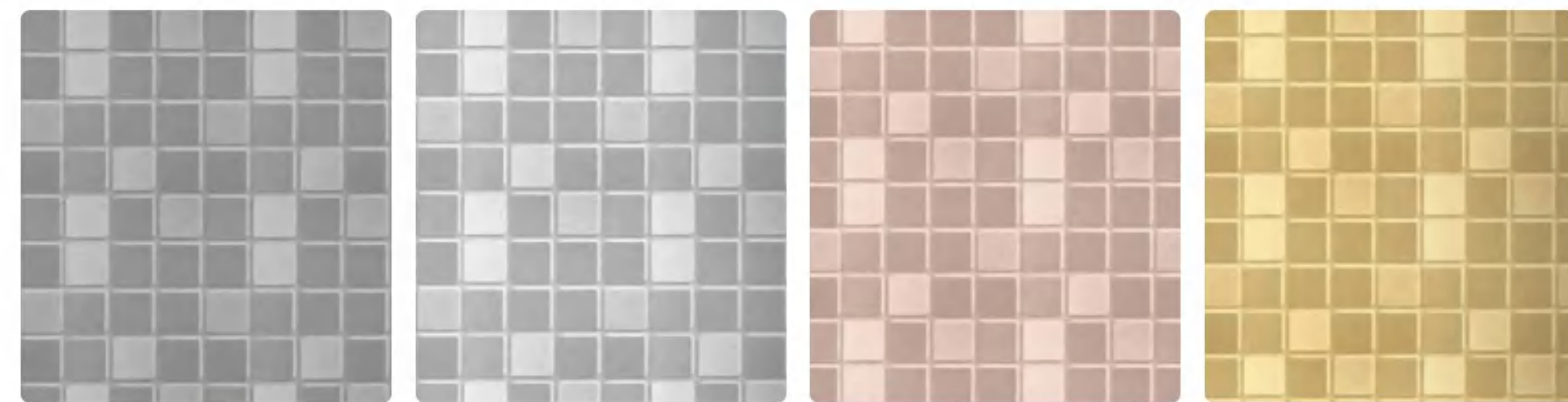

H-401 H-402 H-403 H-404

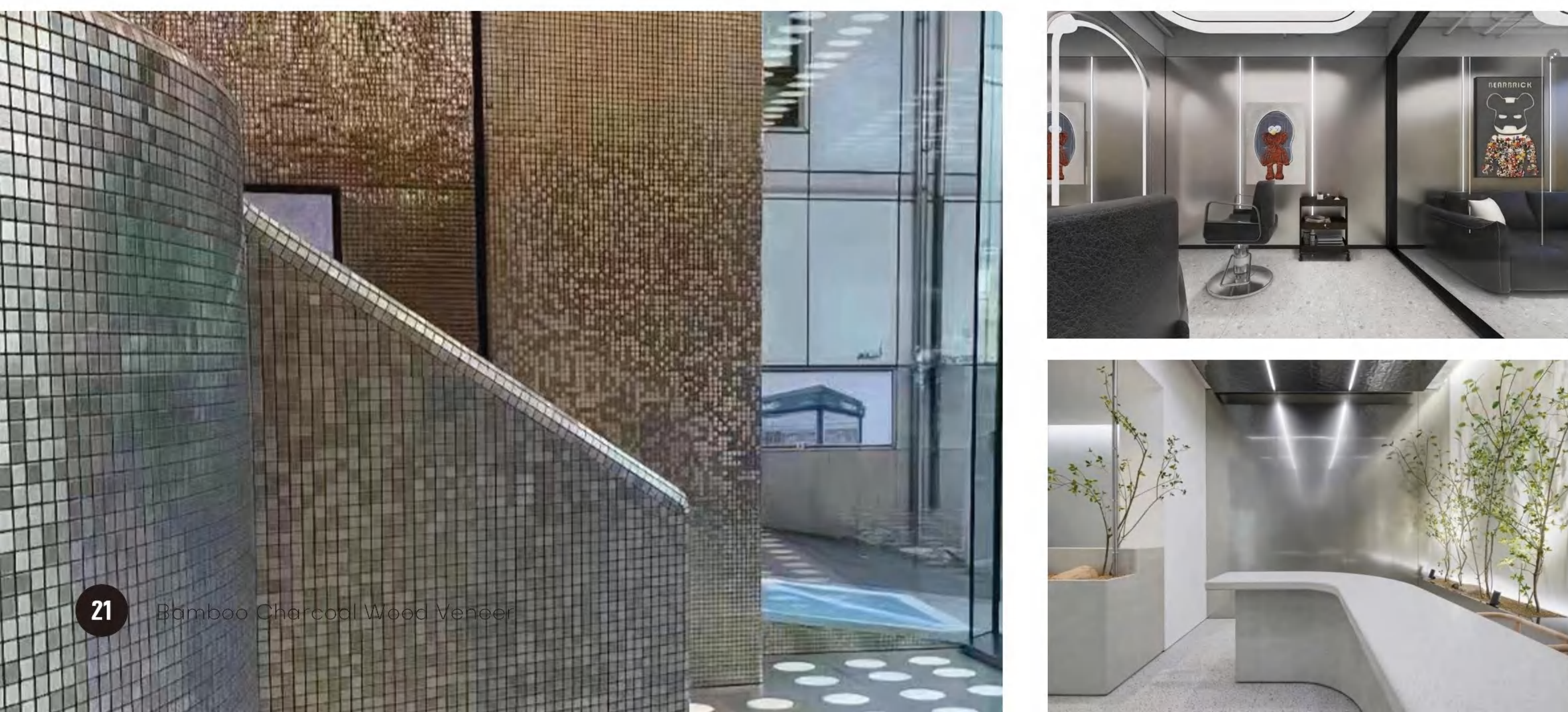

# 04 Bamboo Charcoal Wood Veneer

Hot-selling product series





# 04 Bamboo Charcoal Wood Veneer

Installation Method

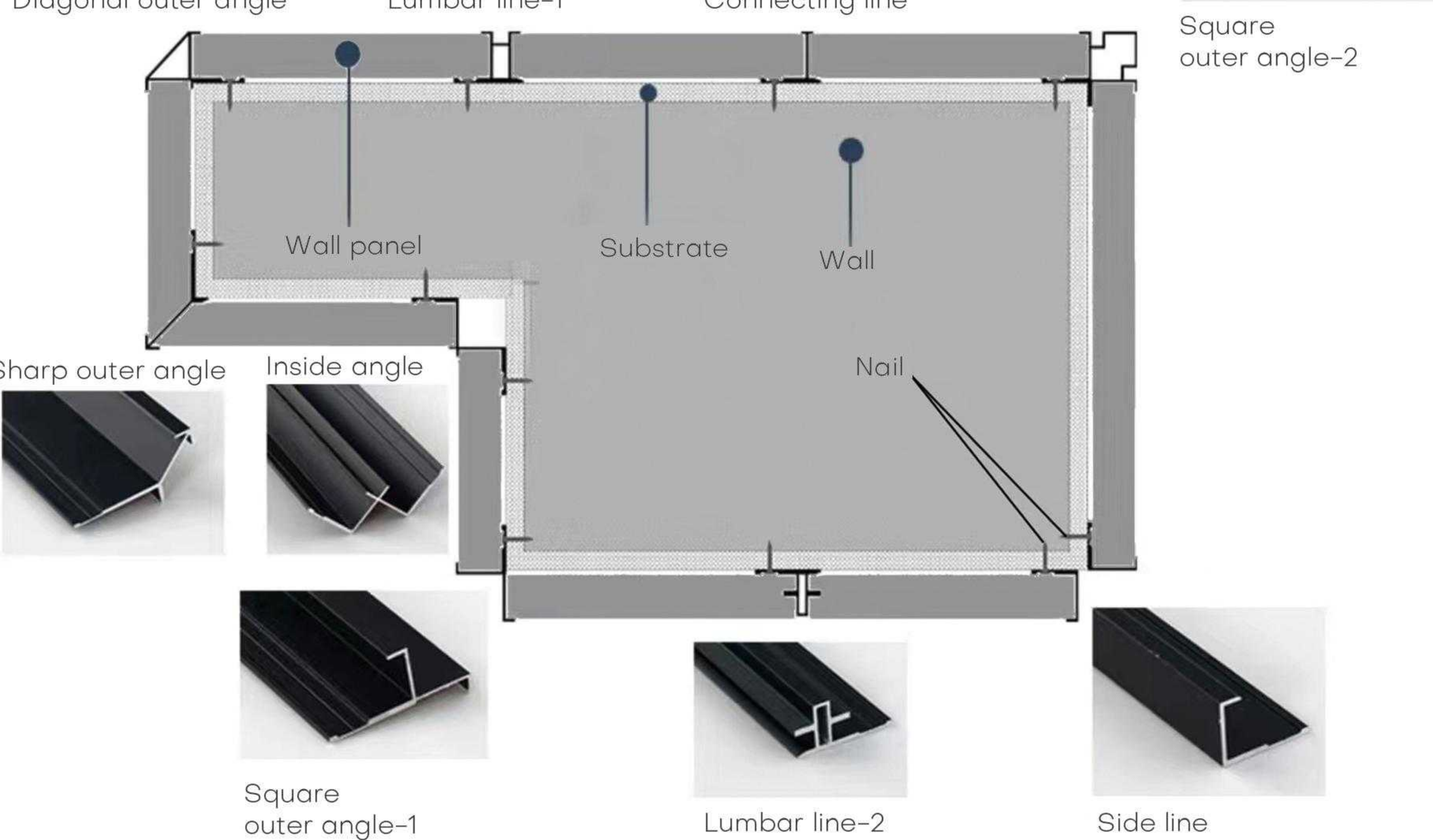
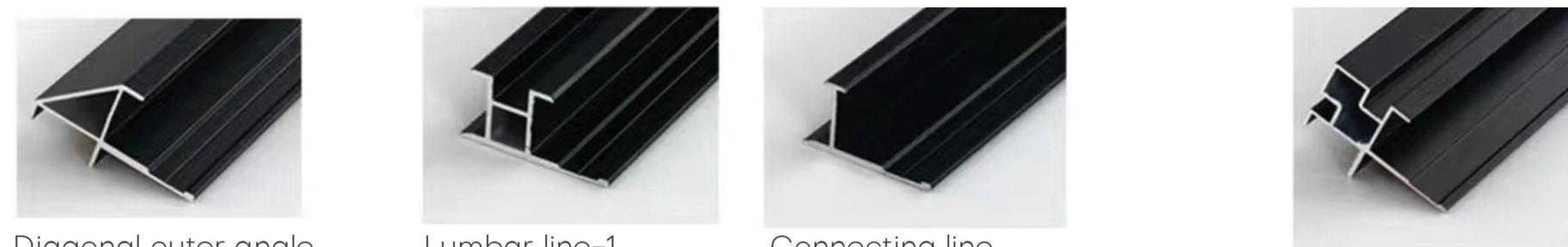
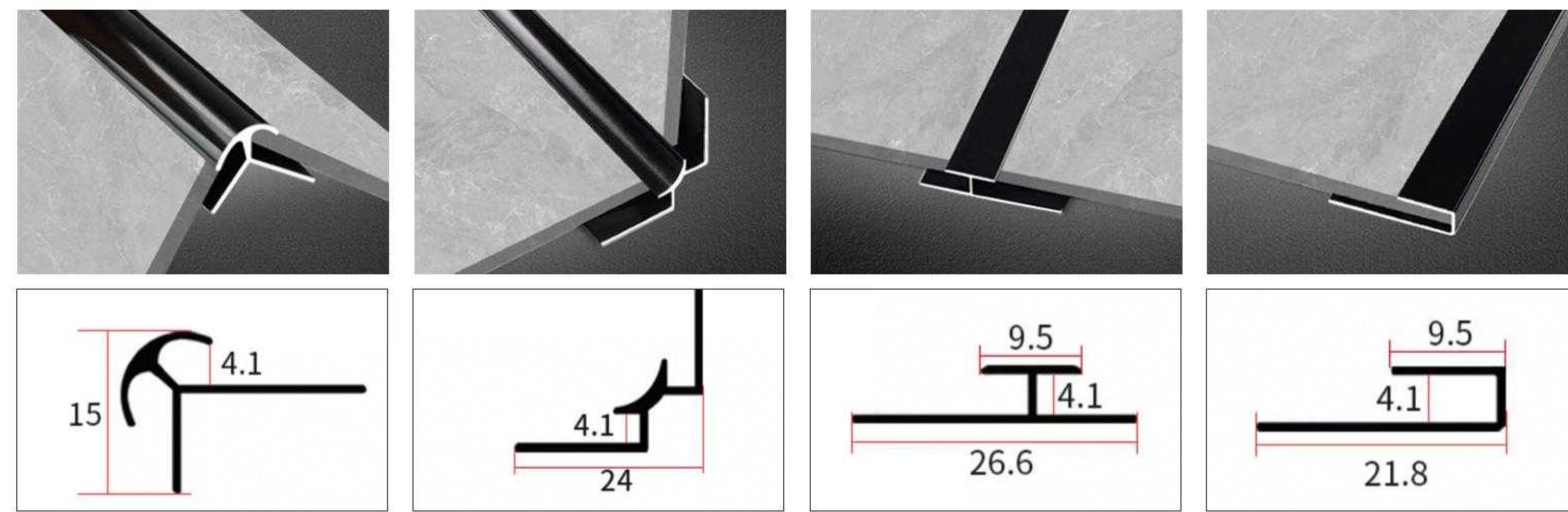

## Installation



Step 1: Cut the WPC foam board to size.  
 Step 2: Apply no-nail free glue to the back.  
 Step 3: Install on the wall.  
 Step 4: Insert the dovetail strips.

# 05 PVC Marble Sheet

Hot-selling product series

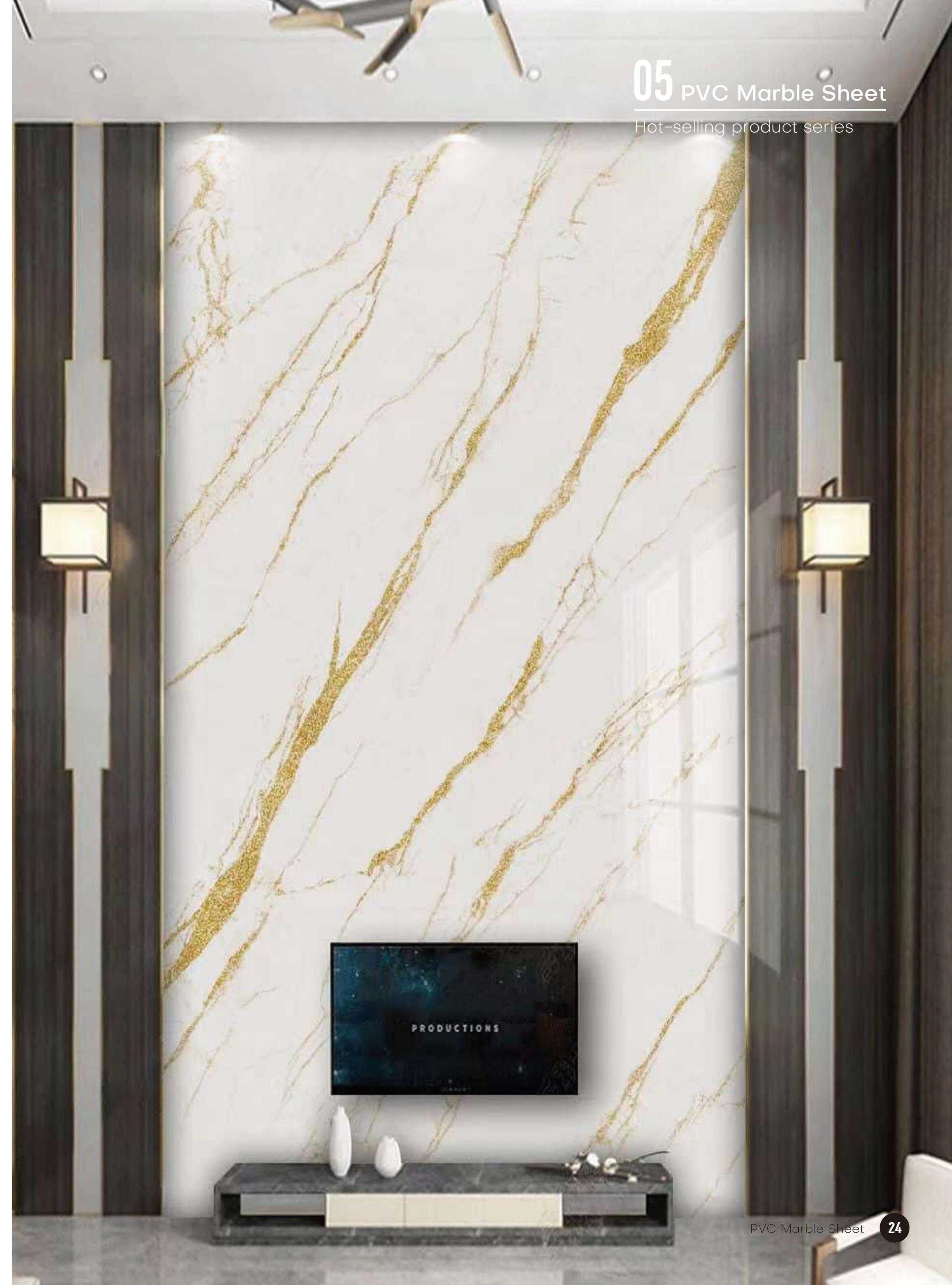



# 05 PVC Marble Sheet

Hot-selling product series

PVC Marble Sheet is an advanced decorative material, also known as UV coating board. It is made of high-density fiberboard or medium-density fiberboard as the base material and processed by a UV coating process. UV board has the advantages of wear resistance, pollution resistance, high-temperature resistance, water and moisture resistance, etc., and also has good surface gloss and tactile feel. It is widely used in furniture, cabinets, wardrobes, office furniture, and other fields, providing high-quality choices for interior decoration. The colors of UV boards are rich and diverse, which can meet the decoration requirements of different styles and needs.

Material	Polyvinyl Chloride/Calcium Powder
Thickness	2.5/2.8/3mm
Size	1220*2440/2800/2900mm
Surface	Hot Stamp/PVC Film/3D Printing

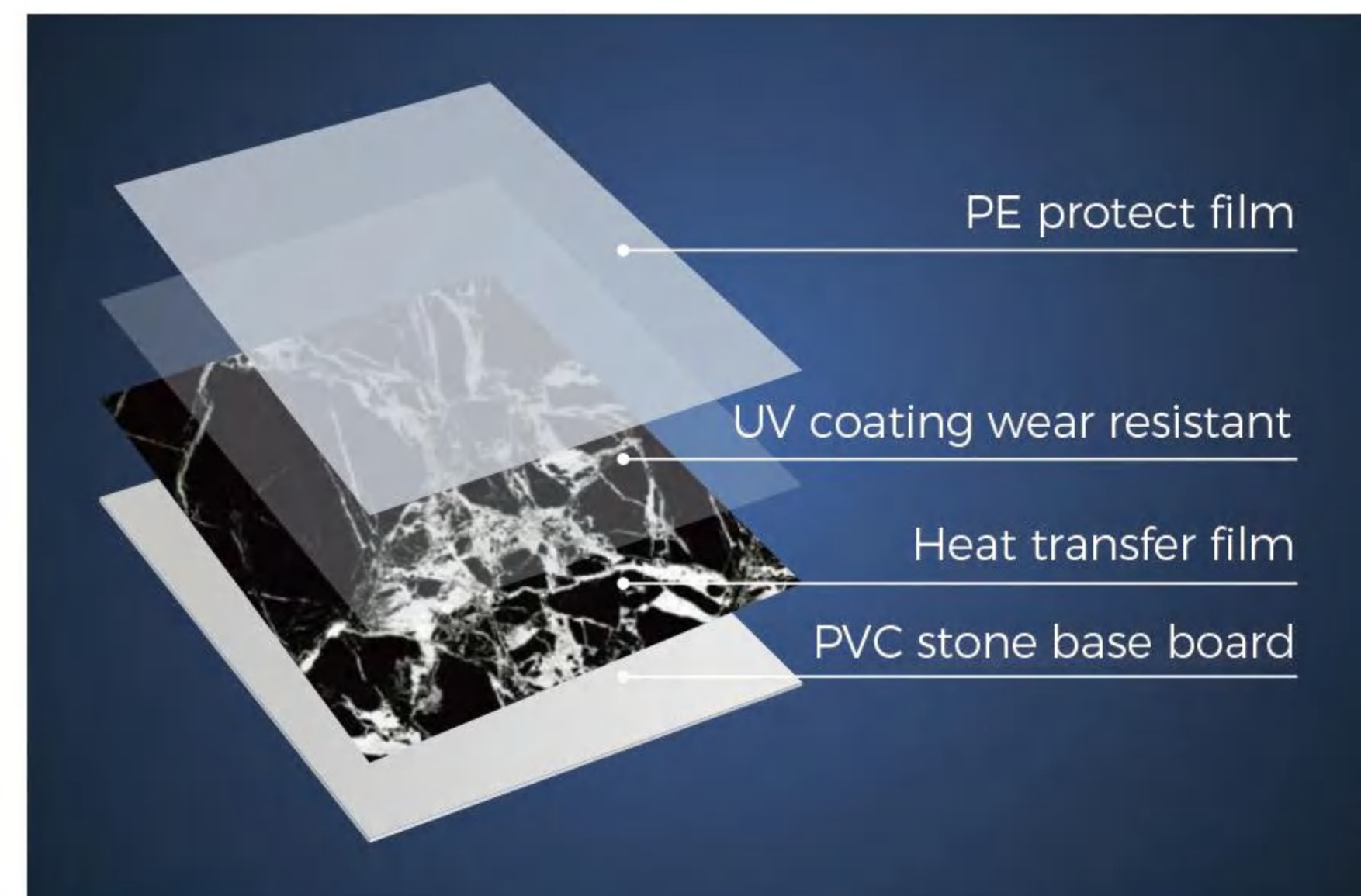

PVC Film

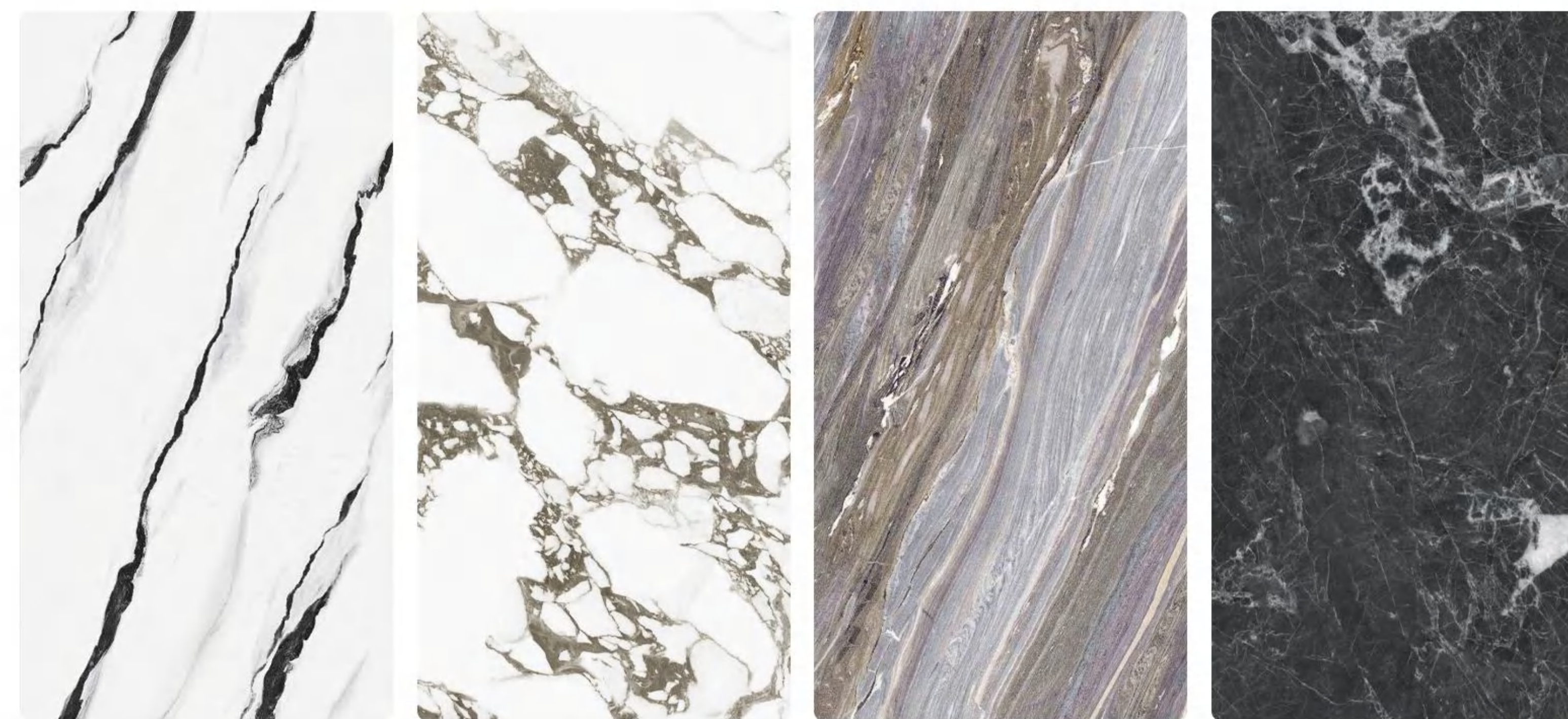

P-001 P-002 P-003 P-004

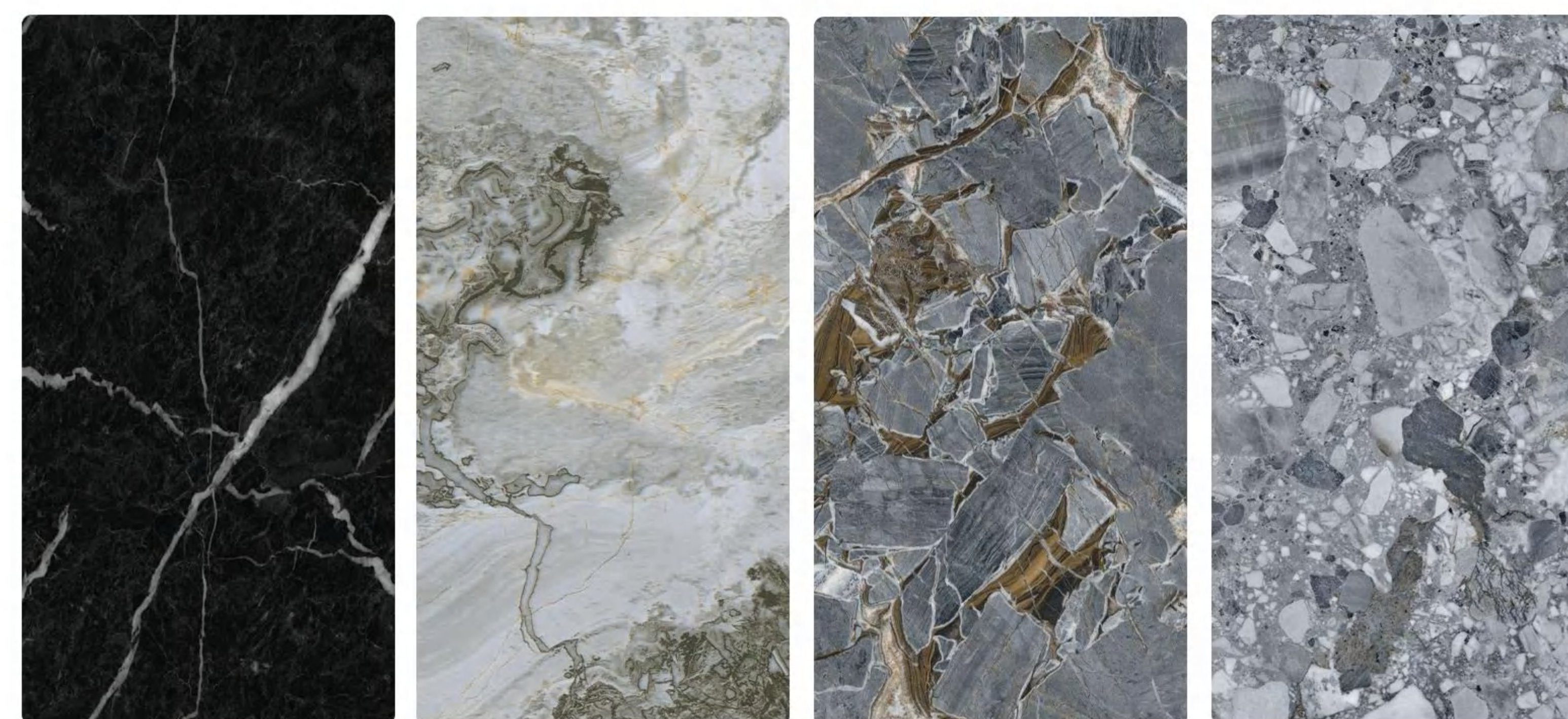

P-005 P-006 P-007 P-008

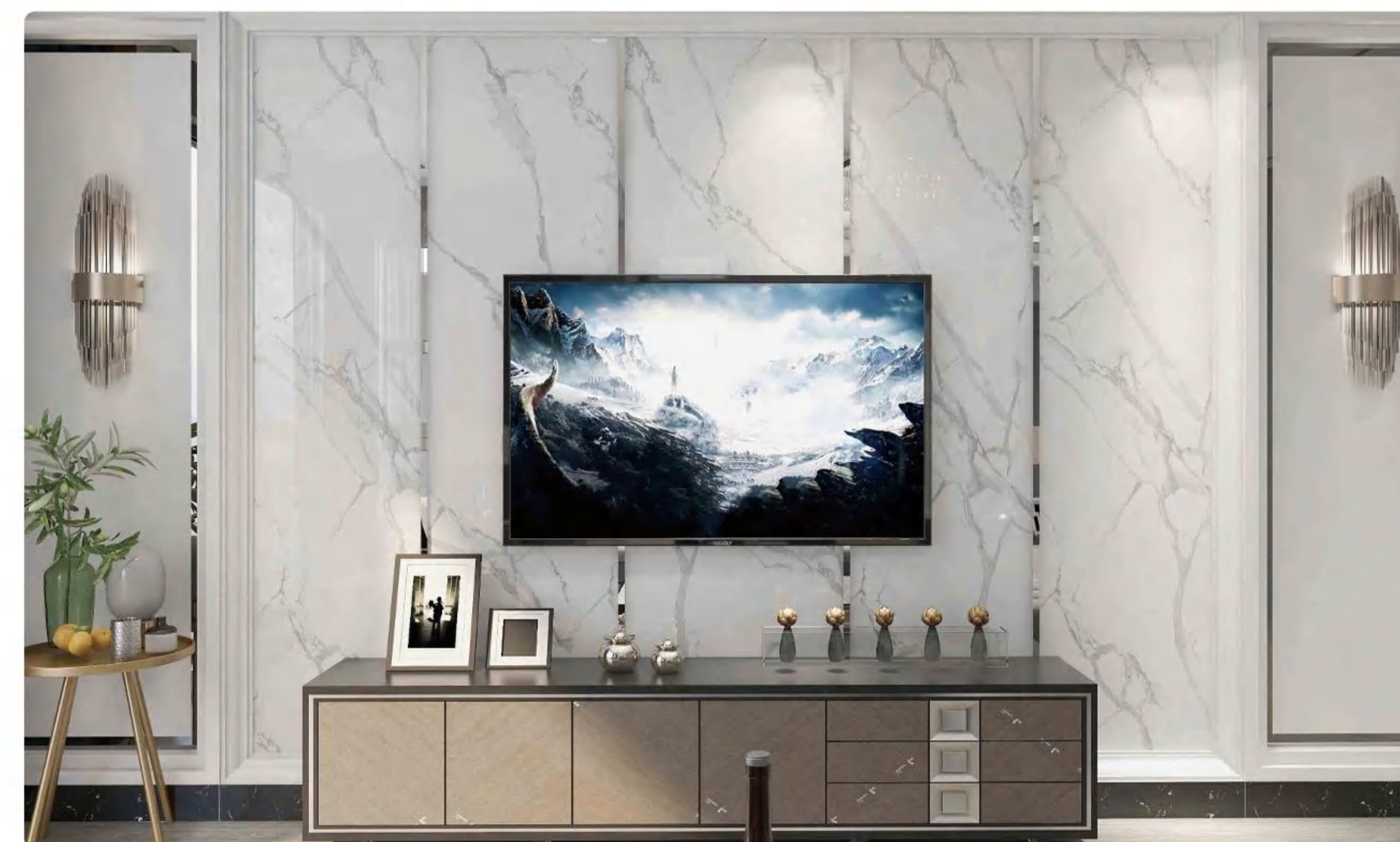

P-009 P-010

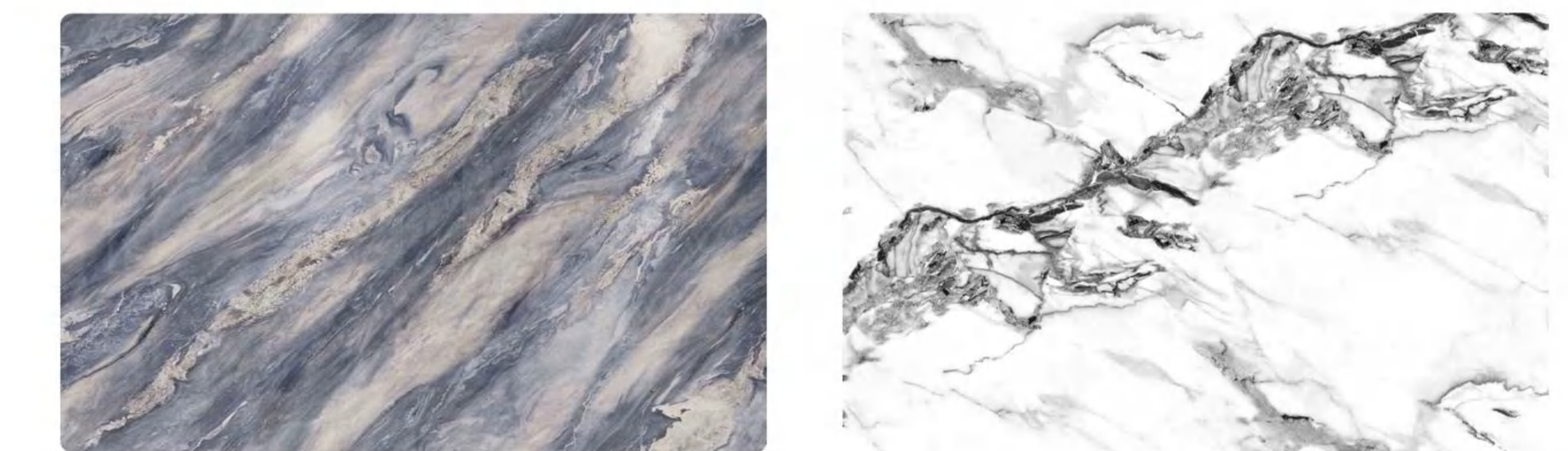

P-011 P-012





# 05 PVC Marble Sheet

Hot-selling product series

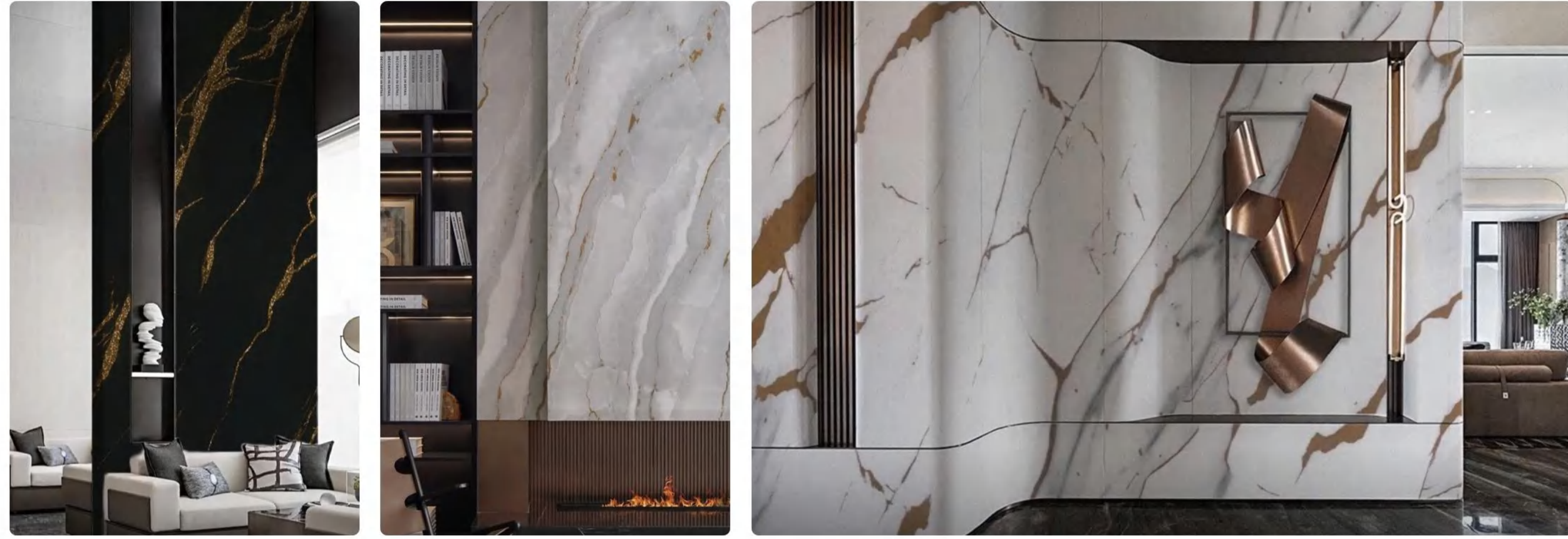

Gilded Marble Sheet

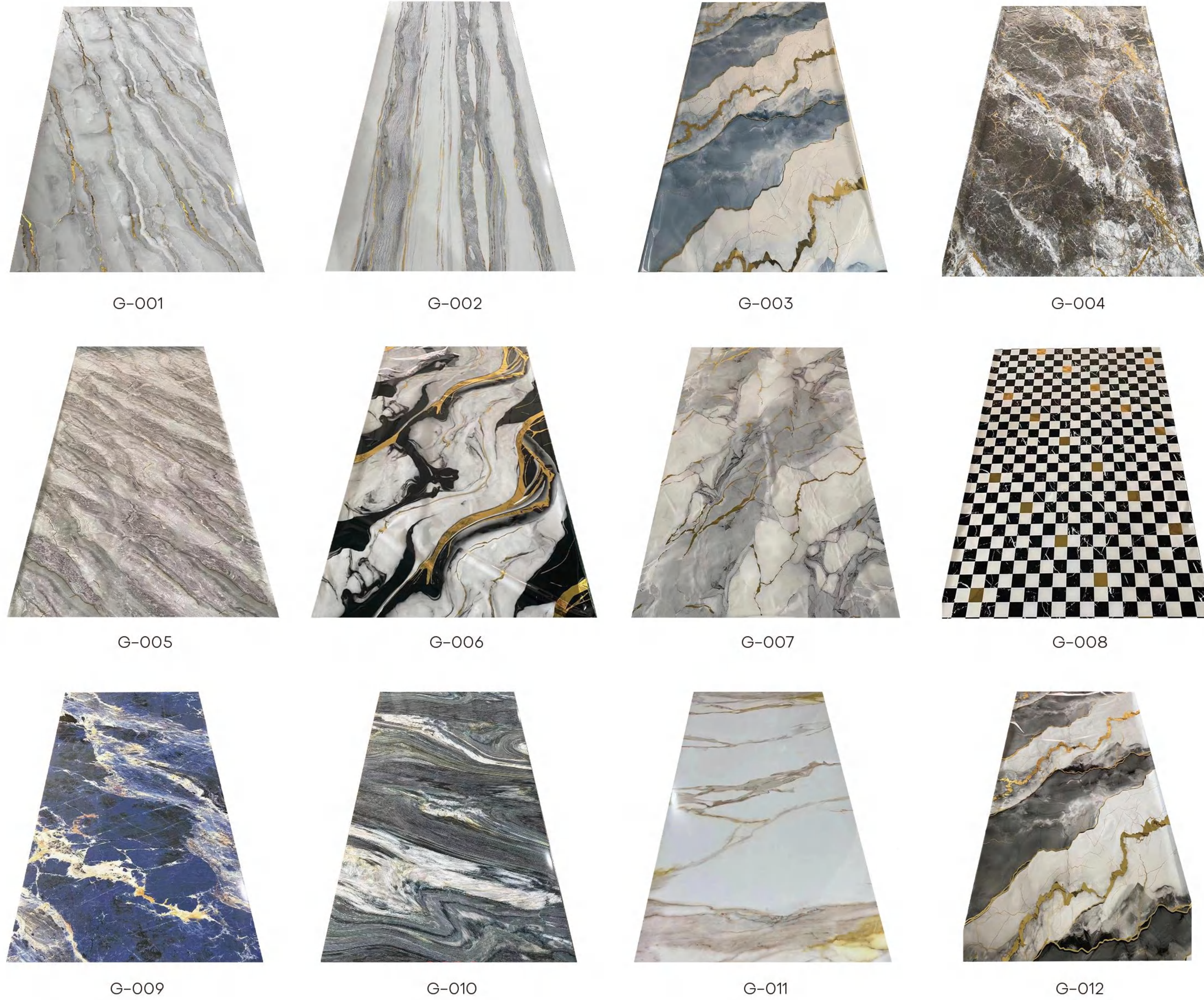

3D Print(Open Book)

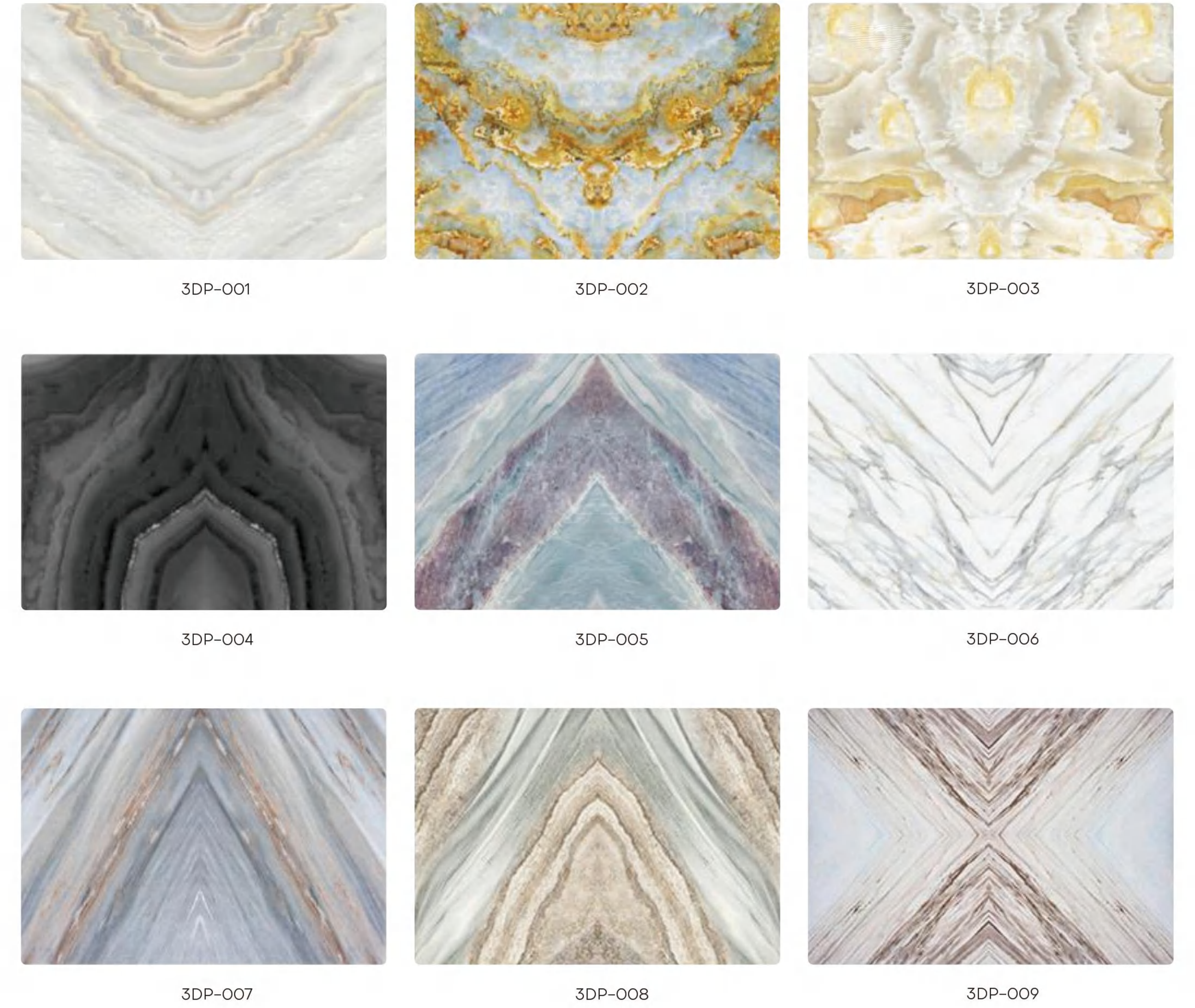



# 05 PVC Marble Sheet

Hot-selling product series

Heat Transfer Printing



H-001



H-002

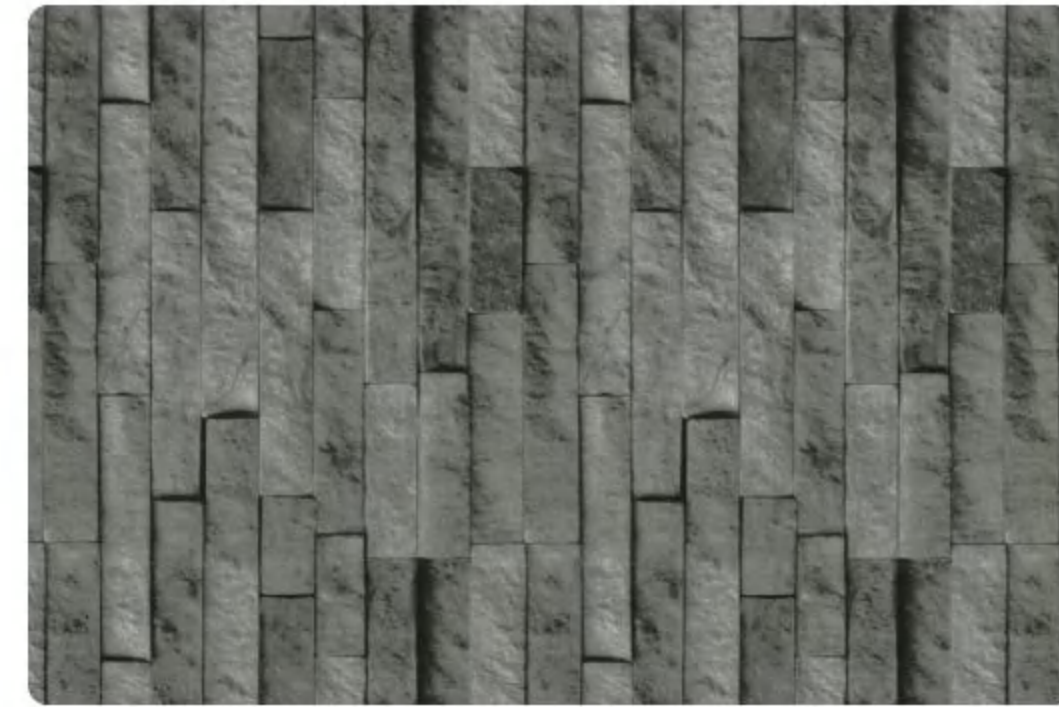

H-003

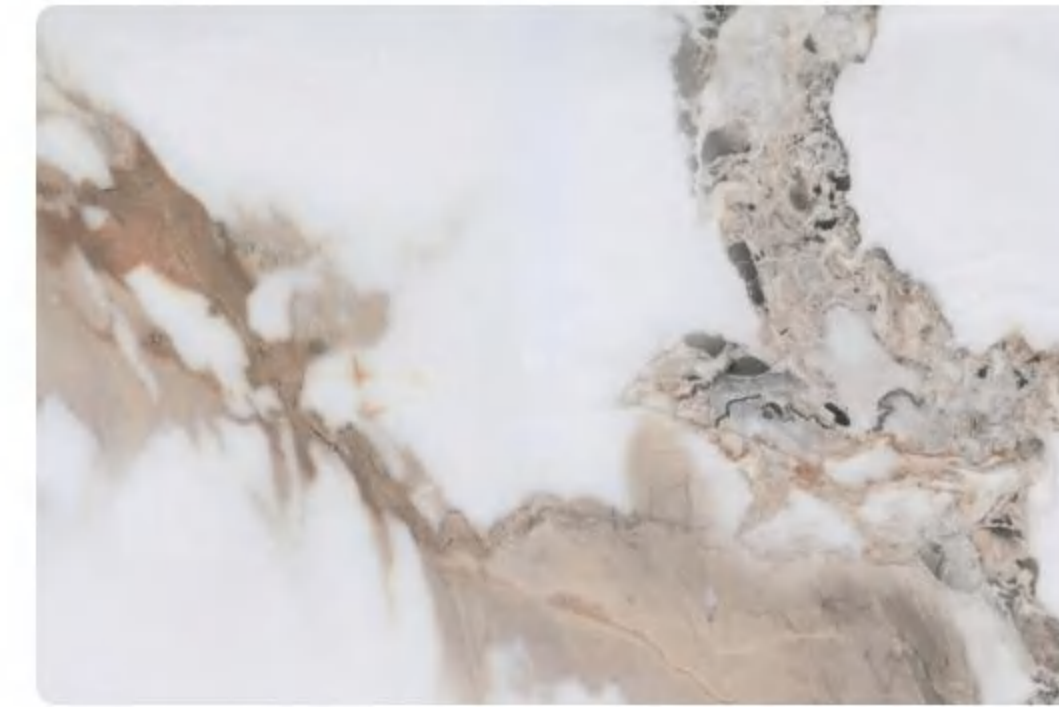

H-004



H-005



H-006

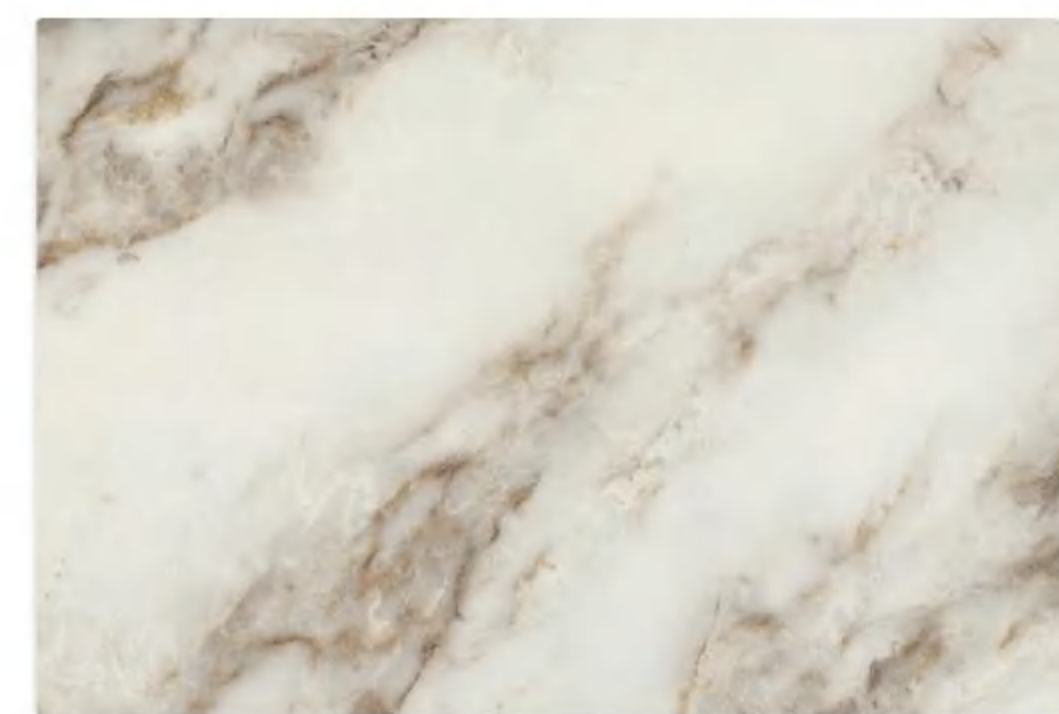

H-007



H-008



H-009



H-010

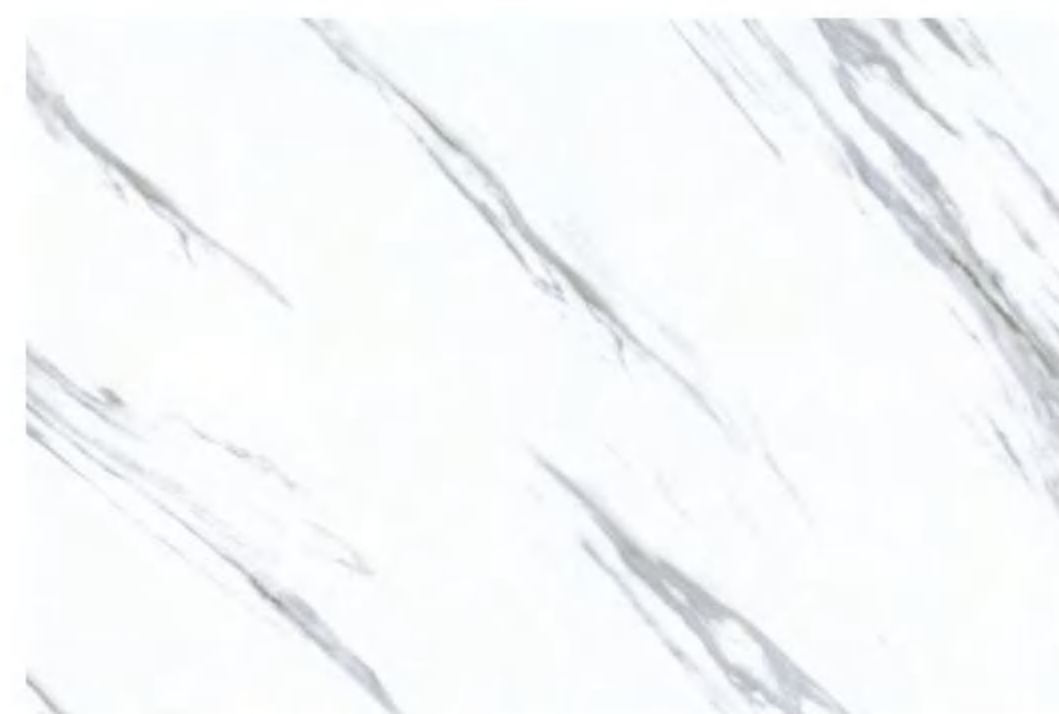

H-011



H-012



3D



3D-001

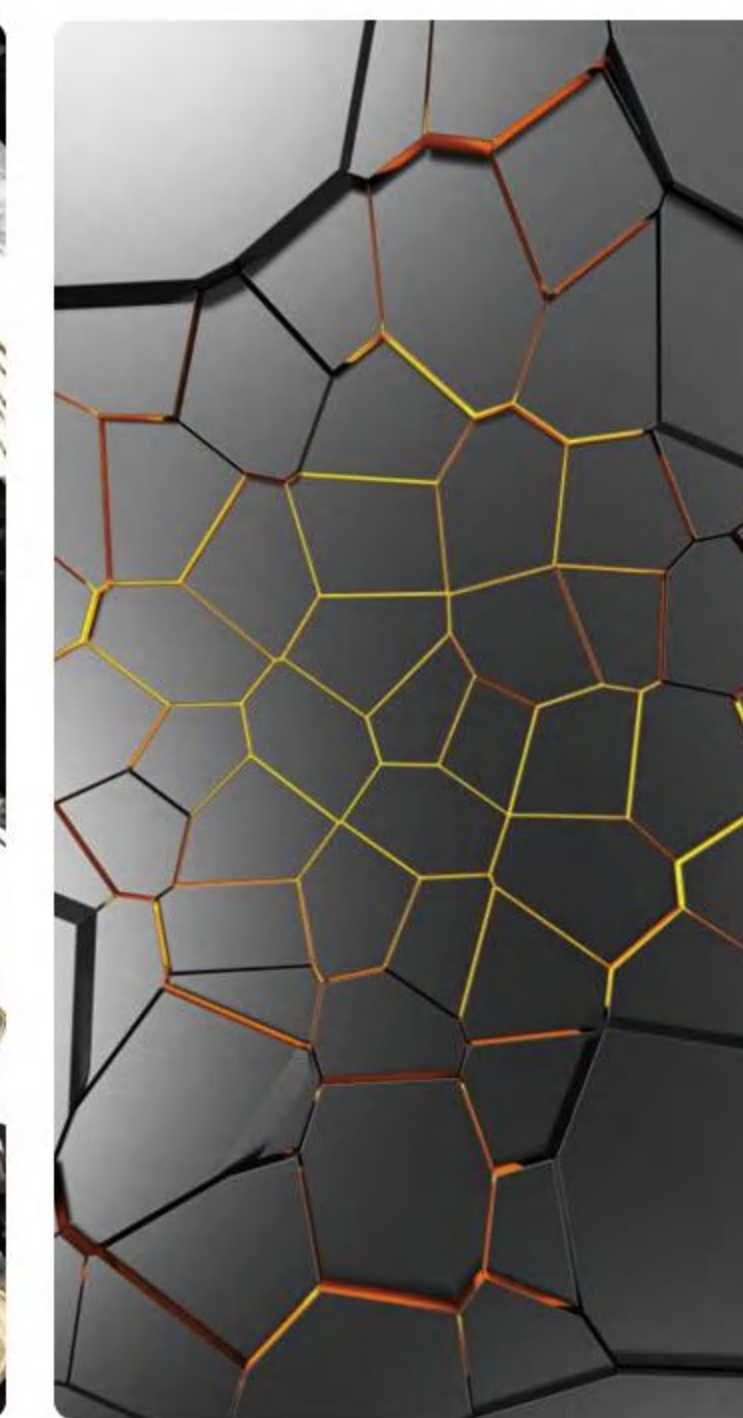

3D-002



3D-003

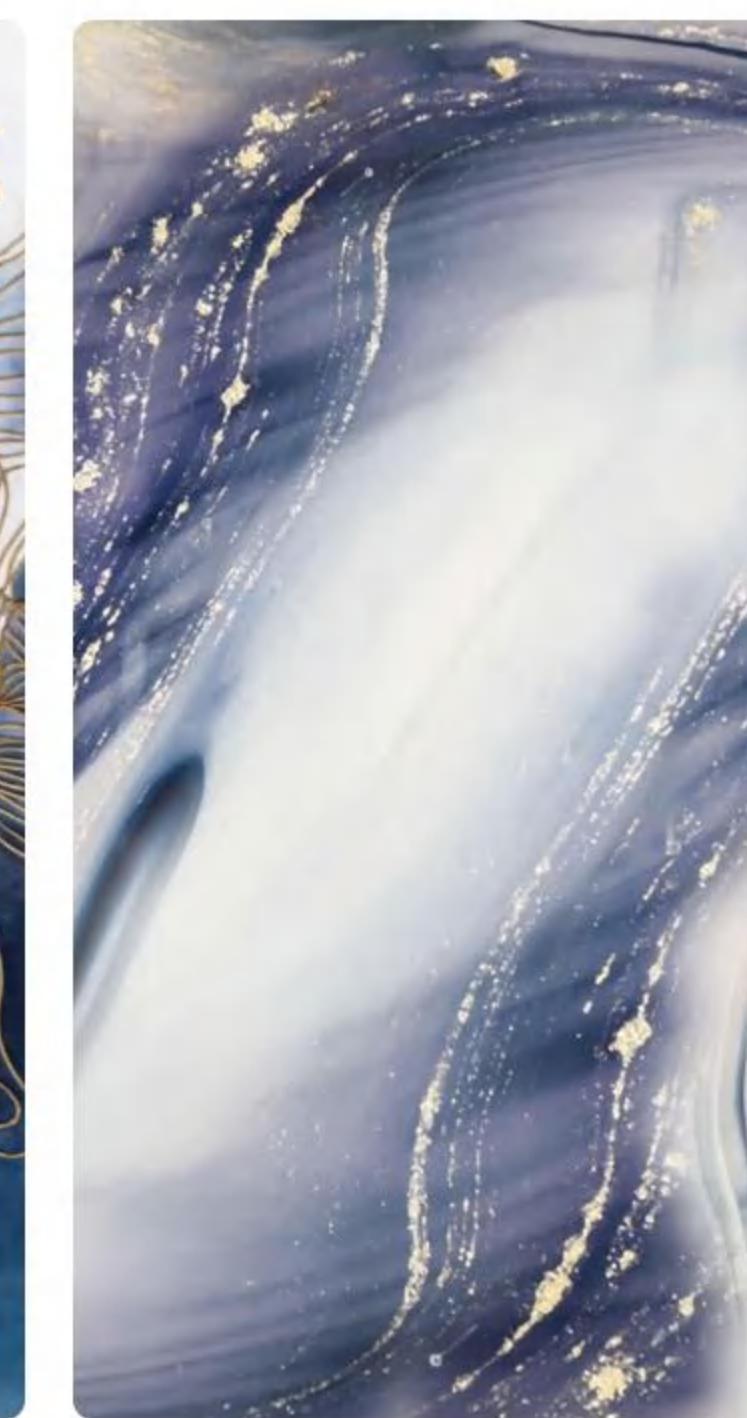

3D-004

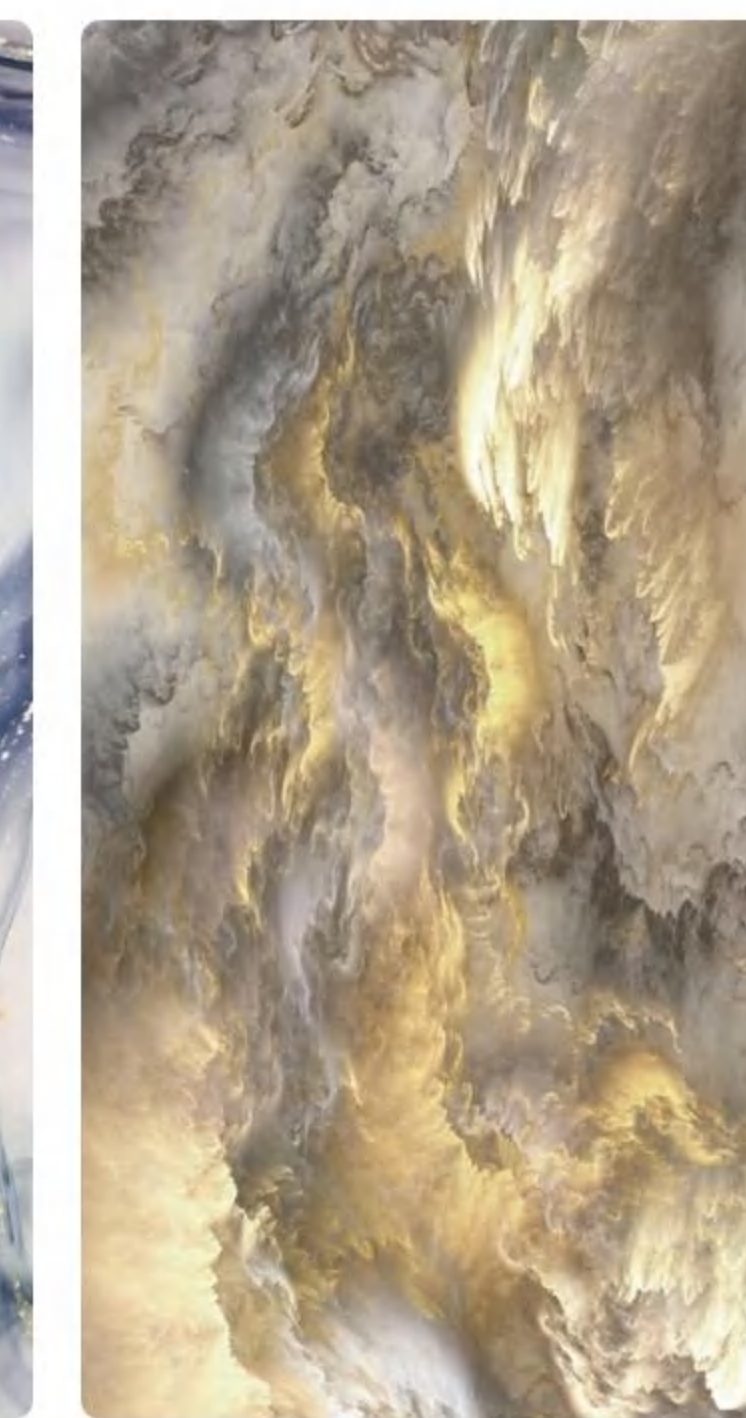

3D-005



3D-006



3D-007

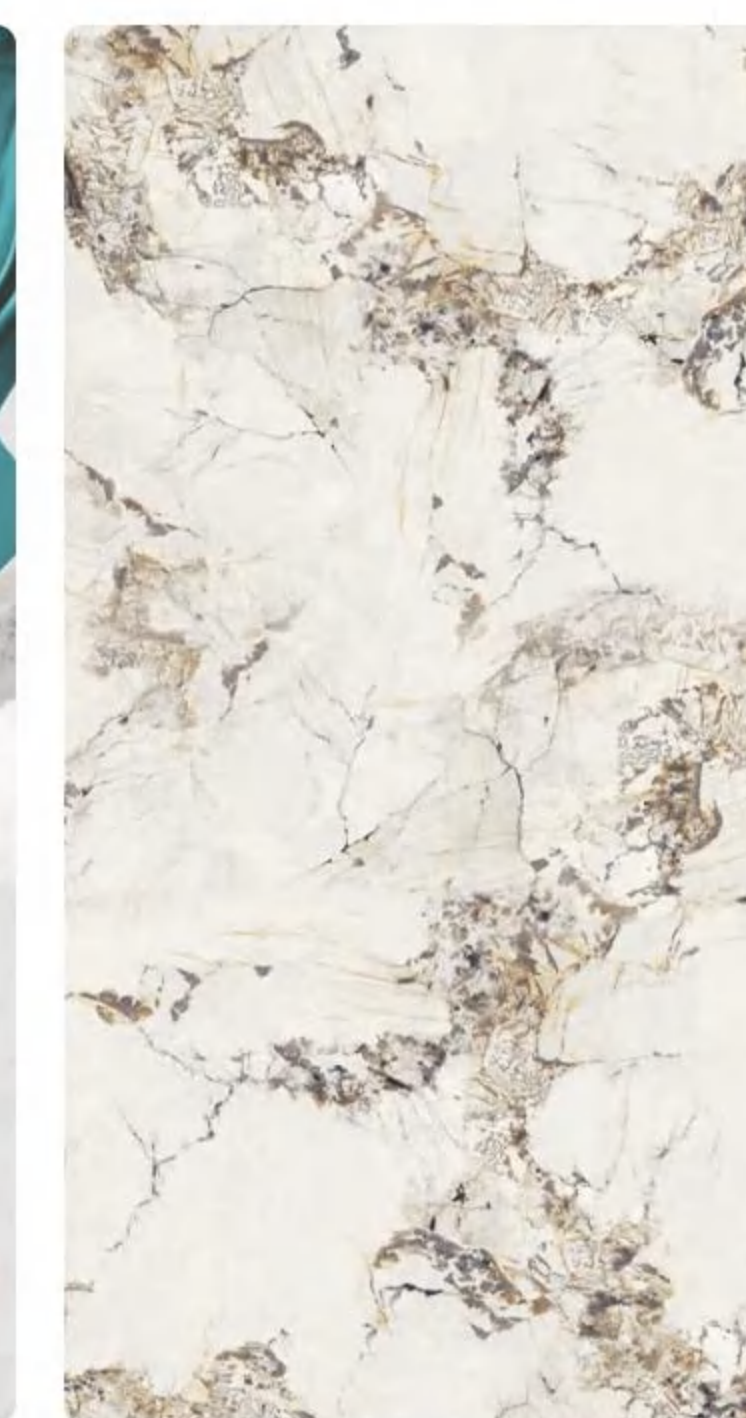

3D-008



3D-009



3D-010



# 05 PVC Marble Sheet

Installation Method



◦ **Step 1**  
Measure the required dimensions.



◦ **Step 2**  
Cut the UV wall panel with a utility knife.



◦ **Step 3**  
Apply nail free glue to the back.



◦ **Step 4**  
Paste it on the wall.

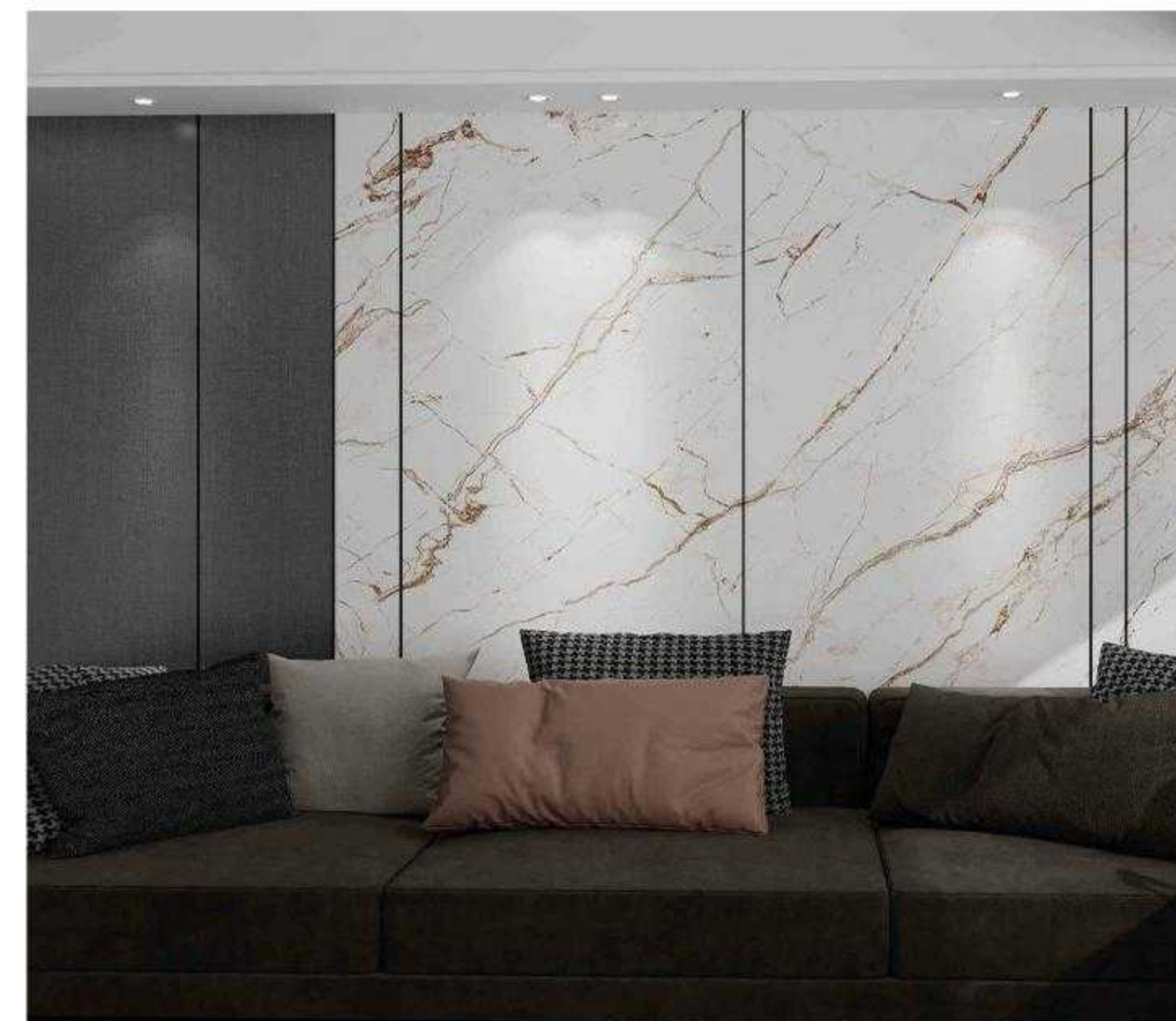
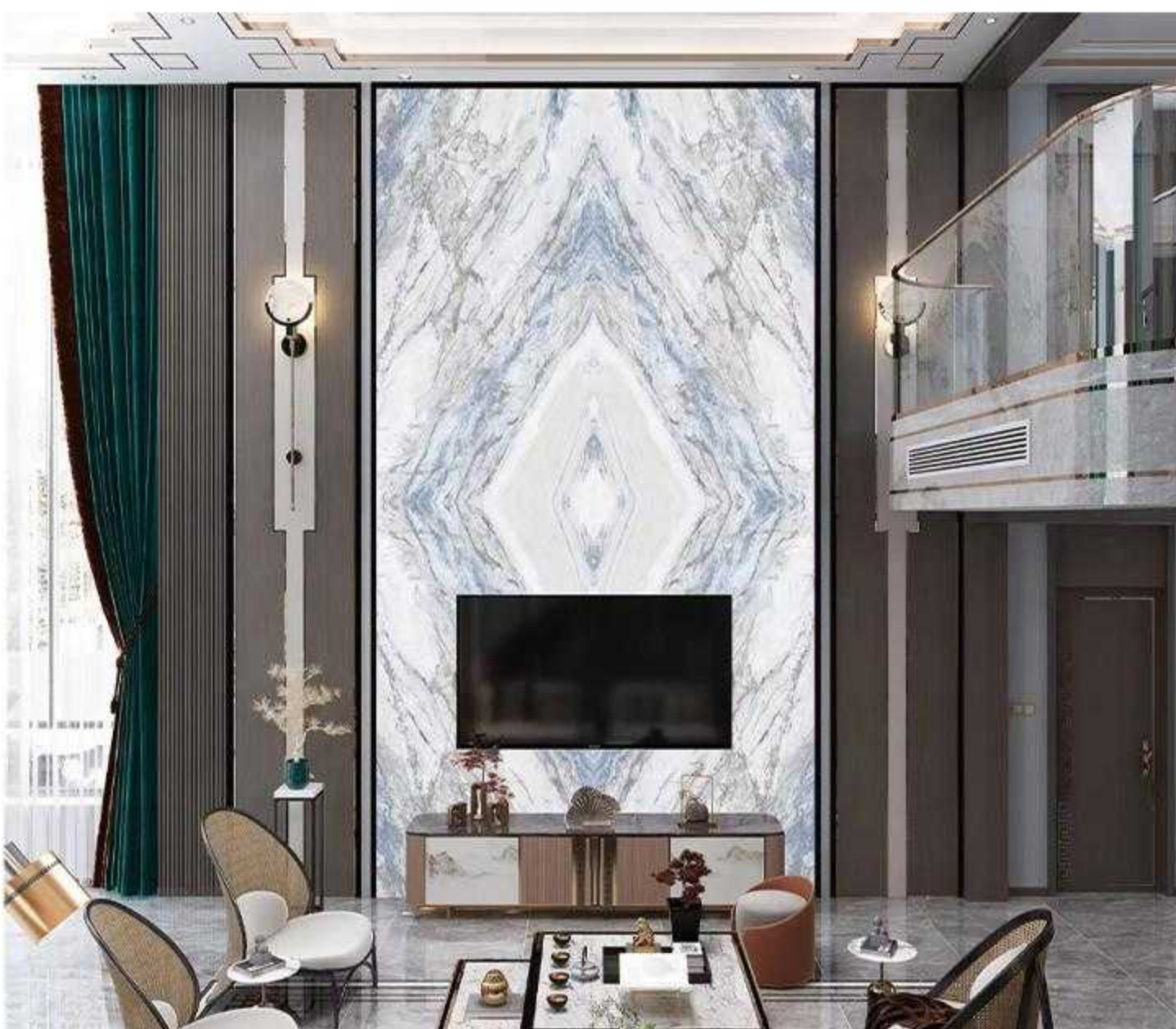

# 06 PS Wall Panel

Hot-selling product series

PS wall panels are made from polystyrene (PS) and have low density, making them lightweight with good sound and thermal insulation. Widely used in construction and decoration, they are easy to install, durable, and have good seismic resistance. Additionally, they can be customized with paint or wallpaper for personalized decorative effects.

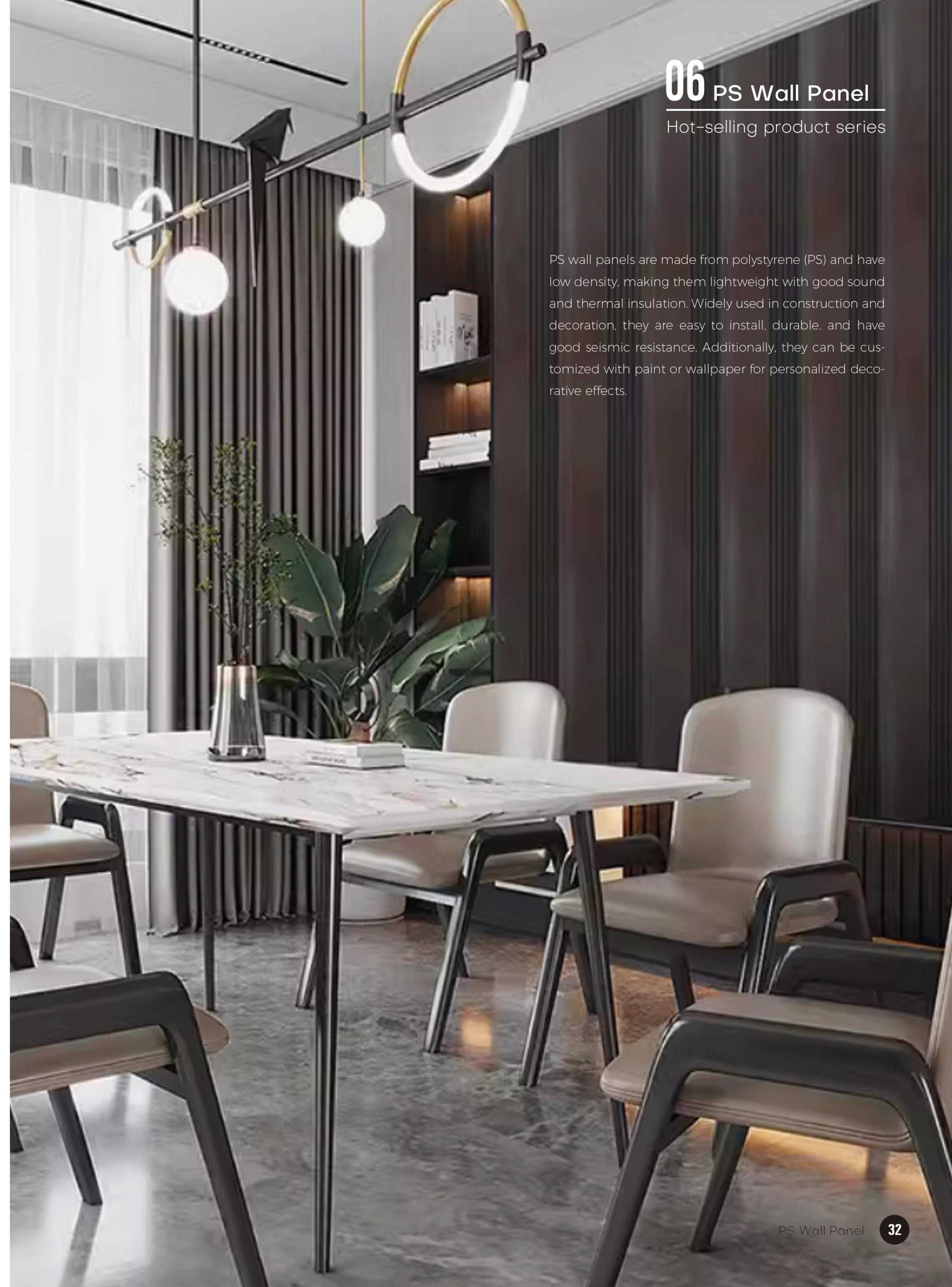



# 06 PS Wall Panel

Hot-selling product series

**CSW M01**  
 W 160mm  
 H 14mm  
 L 2900mm

**CSW M09**  
 W 150mm  
 H 12mm  
 L 2900mm

**CSW M02**  
 W 120mm  
 H 12mm  
 L 2900mm

**CSW M10**  
 W 160mm  
 H 12mm  
 L 2900mm

**CSW M03**  
 W 120mm  
 H 12mm  
 L 2900mm

**CSW M11**  
 W 120mm  
 H 12mm  
 L 2900mm

**CSW M04**  
 W 150mm  
 H 10mm  
 L 2900mm

**CSW M12**  
 W 120mm  
 H 12mm  
 L 2900mm

**CSW M05**  
 W 120mm  
 H 10mm  
 L 2900mm

**CSW M13**  
 W 120mm  
 H 11.2mm  
 L 2900mm

**CSW M06**  
 W 120mm  
 H 20mm  
 L 2900mm

**CSW M14**  
 W 120mm  
 H 12mm  
 L 2900mm

**CSW M07**  
 W 120mm  
 H 12mm  
 L 2900mm

**CSW M15**  
 W 120mm  
 H 12mm  
 L 2900mm

**CSW M08**  
 W 160mm  
 H 12mm  
 L 2900mm

**CSW M16**  
 W 160mm  
 H 20mm  
 L 2900mm



**CSW S01**  
 W 300mm  
 H 7mm  
 L 2900mm

**CSW S02**  
 W 300mm  
 H 7mm  
 L 2900mm

**CSW S03**  
 W 300mm  
 H 7mm  
 L 2900mm

**CSW S04**  
 W 300mm  
 H 7mm  
 L 2900mm

**CSW S05**  
 W 300mm  
 H 7mm  
 L 2900mm

**CSW S06**  
 W 300mm  
 H 7mm  
 L 2900mm

**CSW S07**  
 W 300mm  
 H 8mm  
 L 2900mm



# 06 PS Wall Panel

Installation Method

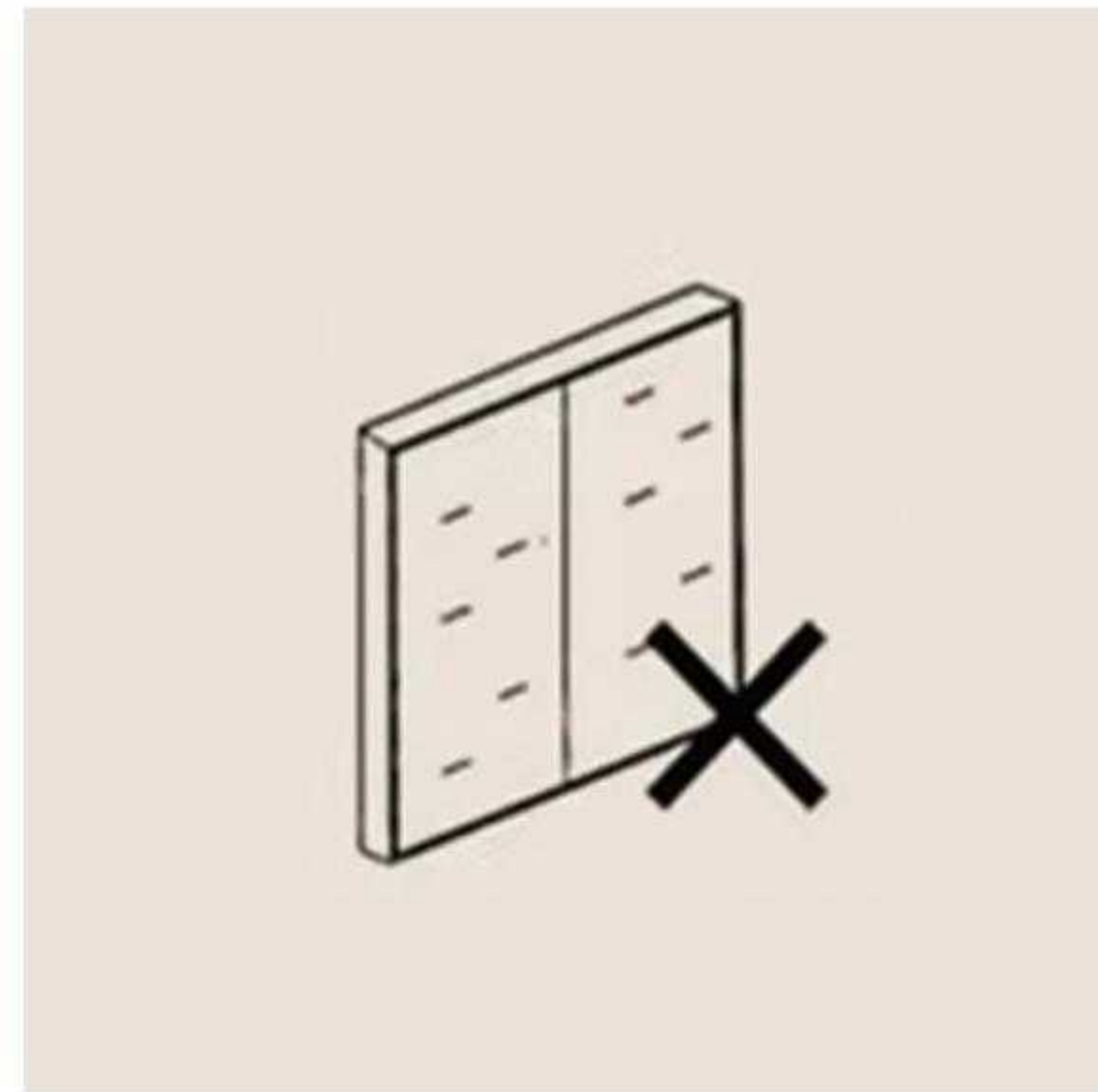

- **Step 1**  
Clean the wall surface thoroughly and ensure it is flat.

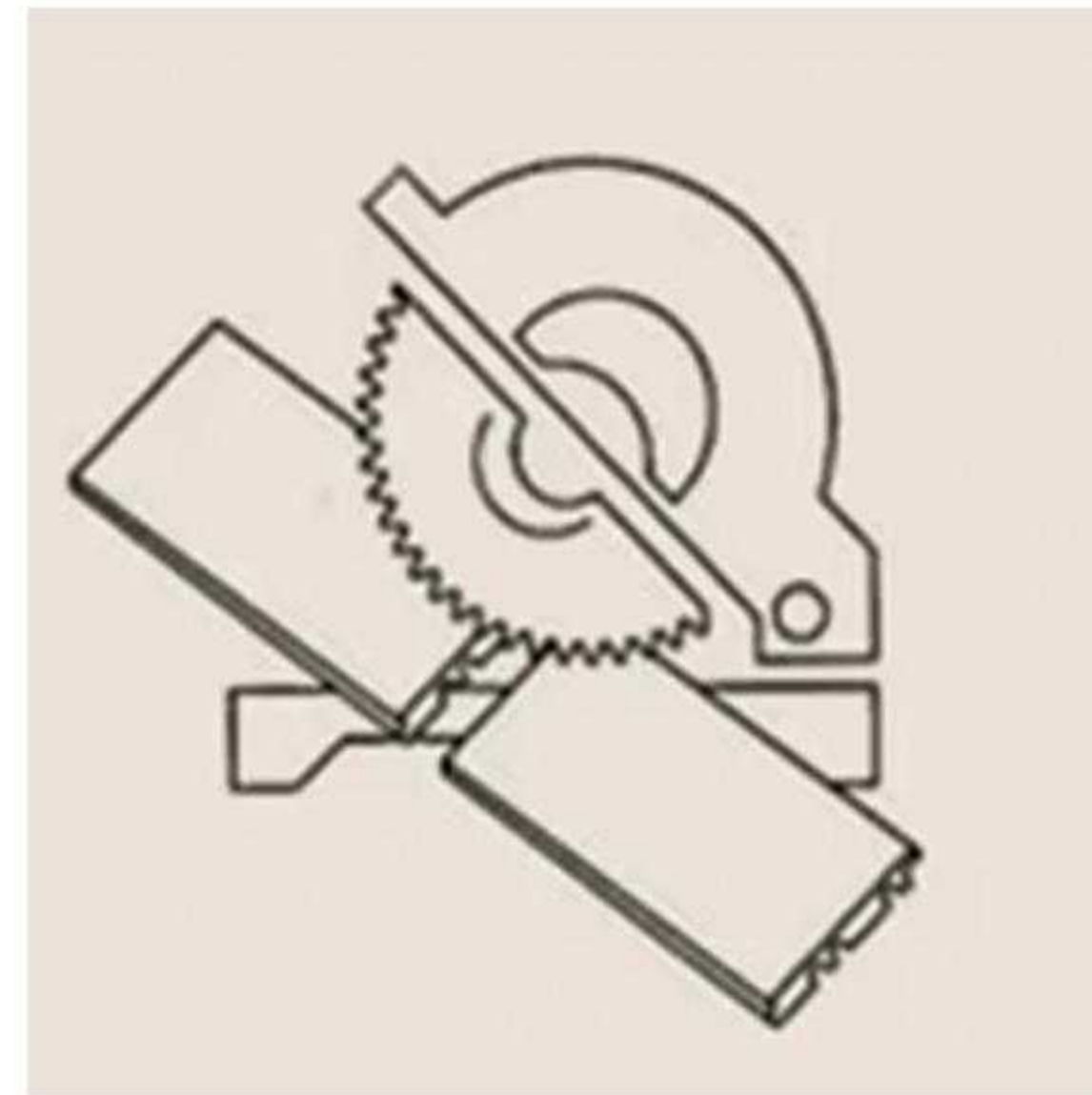

- **Step 2**  
Measure and cut the panels to fit.

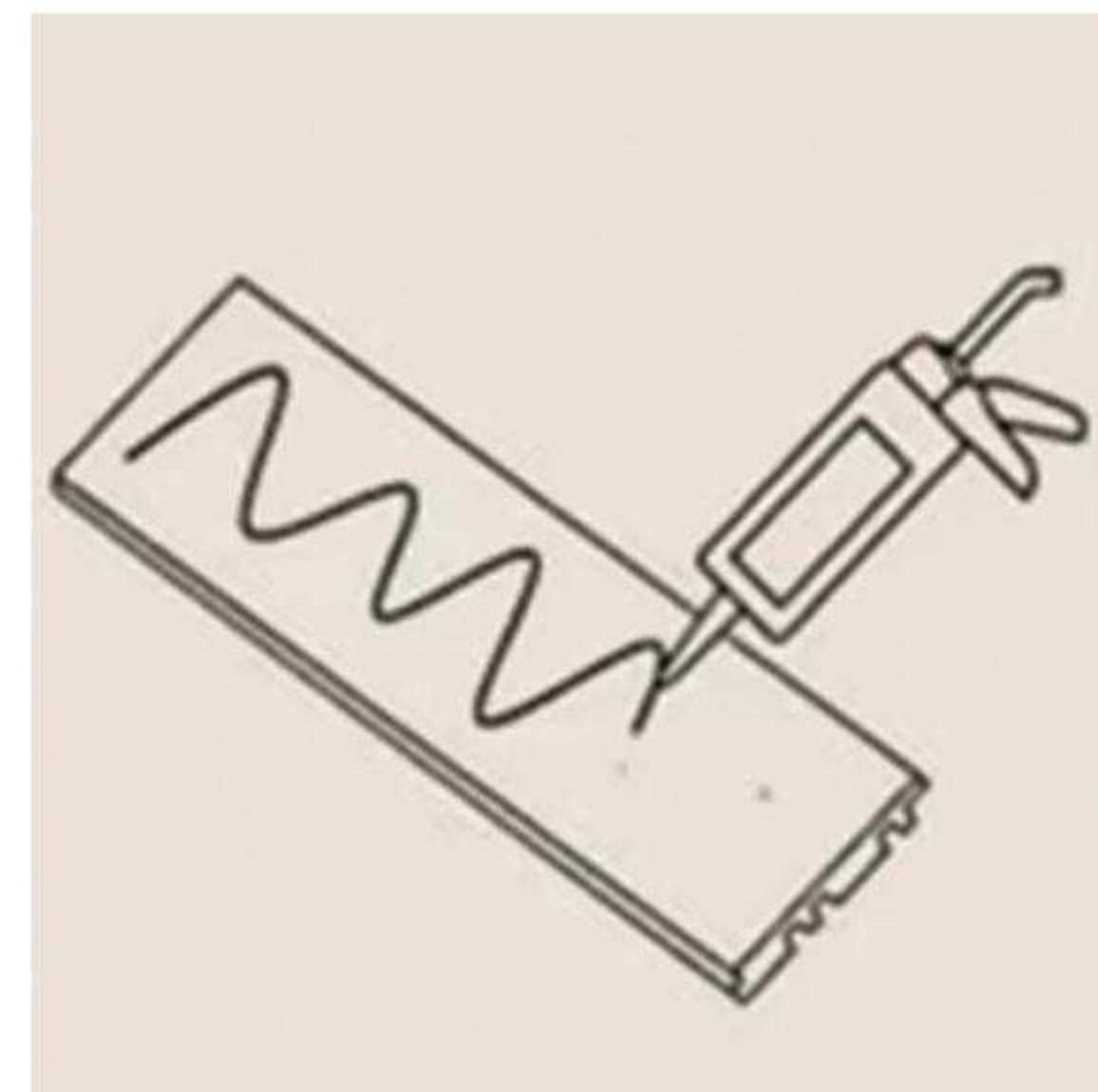

- **Step 3**  
Apply nail free glue to the back.

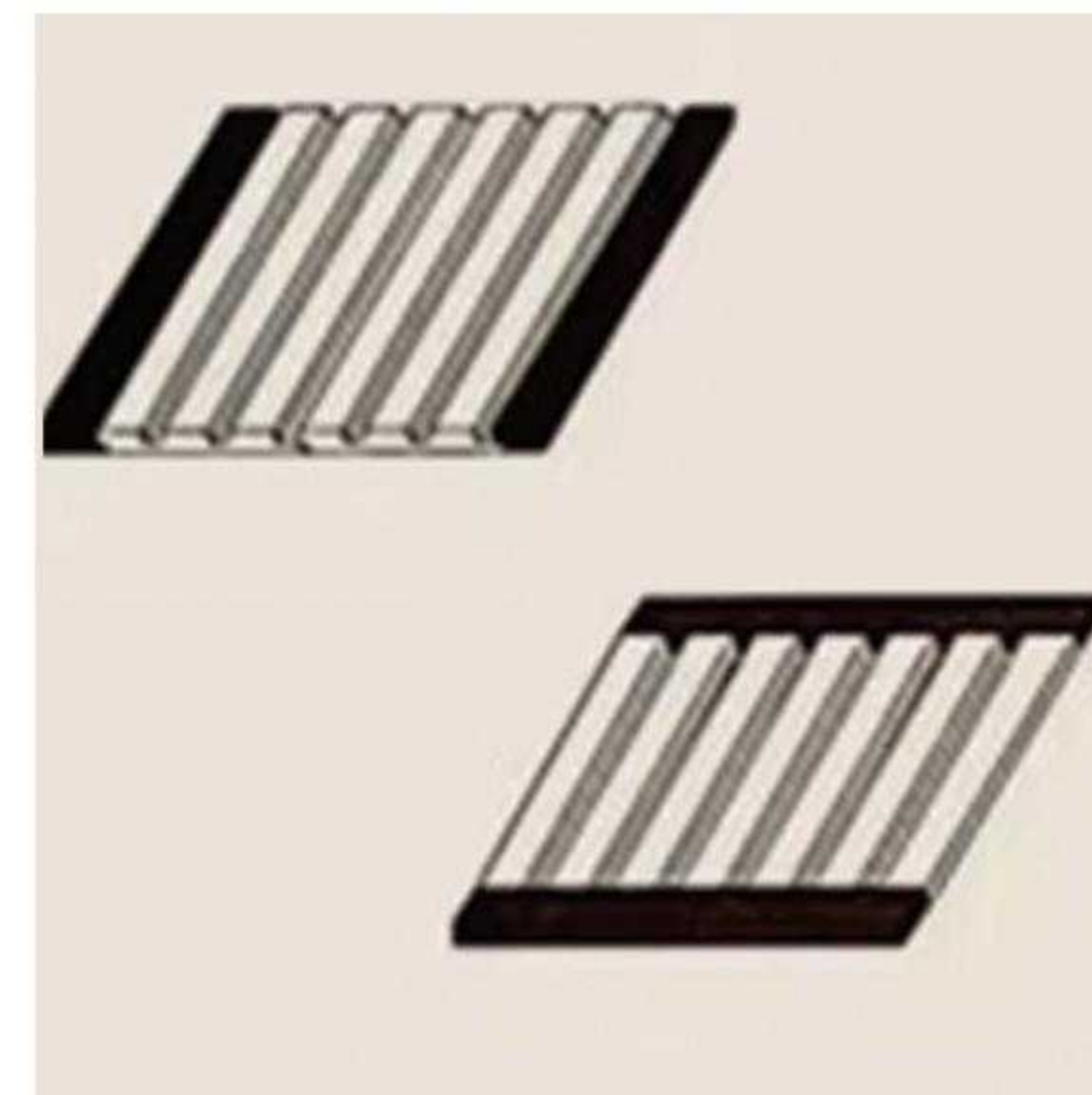

- **Step 4**  
Complete the installation.

# 07 Slat Acoustic Panel

Hot-selling product series





# 07 Slat Acoustic Panel

Hot-selling product series

Slat Acoustic Panels provide an excellent look and improve acoustics by absorbing echoes and reverberations, making the room environment more pleasant. Slat Acoustic Panels can be widely used on walls and ceilings in living rooms, corridors, kitchens, children's rooms, bedrooms, and offices. They are also suitable for public spaces, shops, restaurants, and more.



Tech Veneer



Natural Veneer



Dyed/Smoked



Melamine

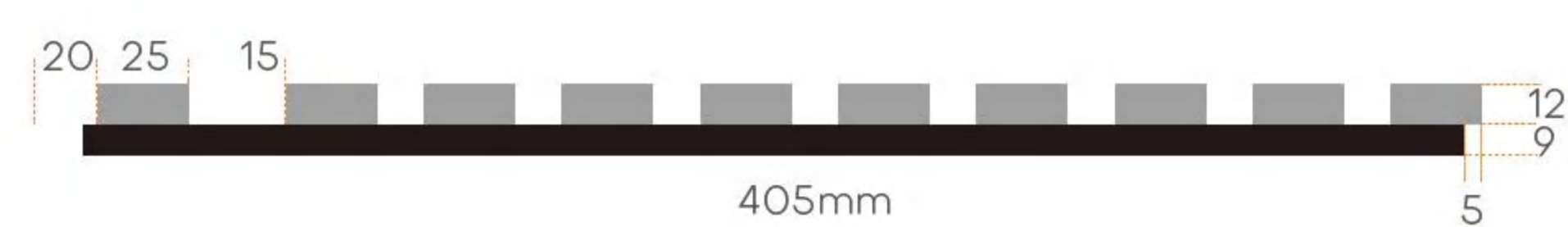
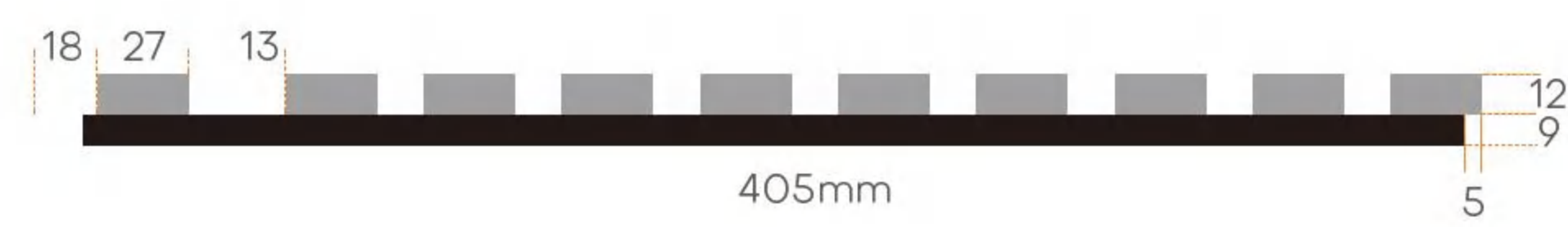

Full Panel Size: 2400~3000mm x 600/400mm x 22mm

\*We have more other customized size



- Absorb the noise
- Sound insulation
- Moistureproof
- Environmental protection

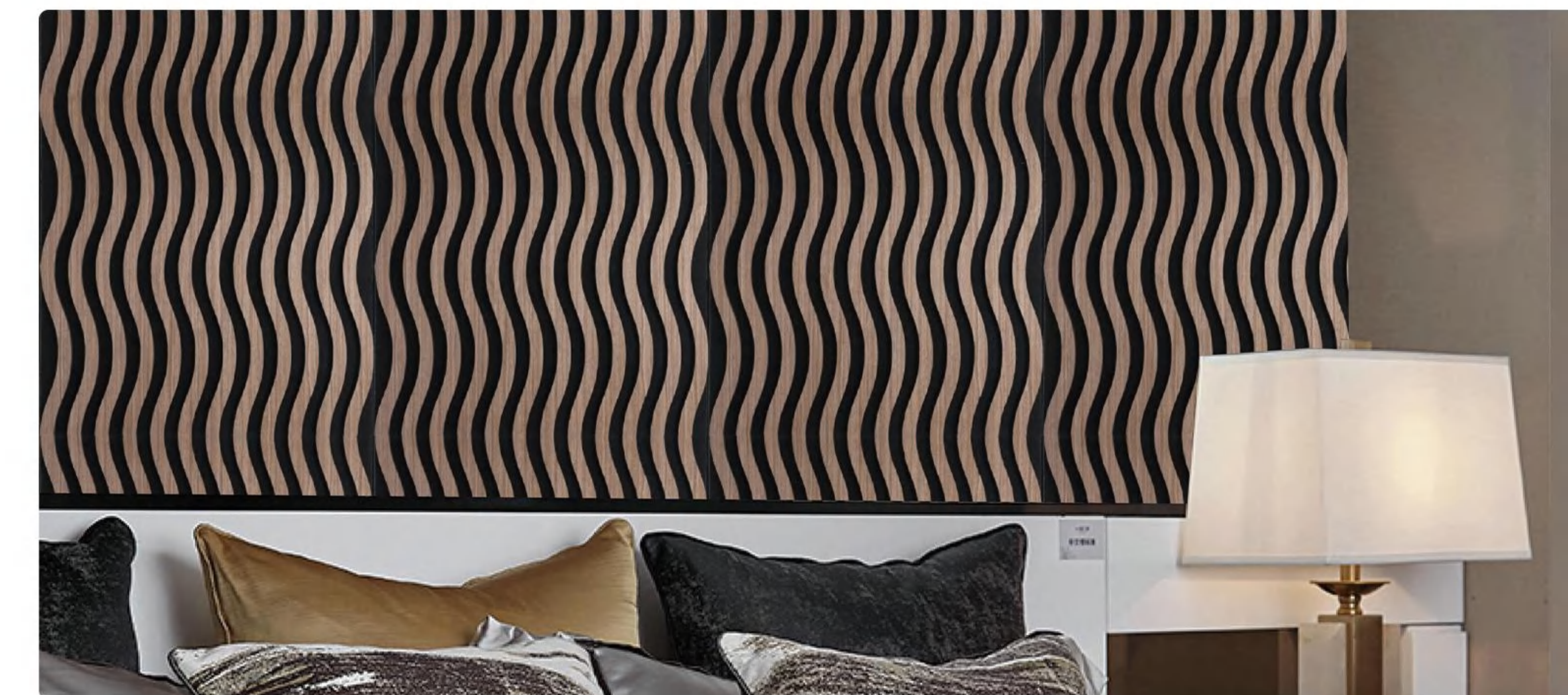
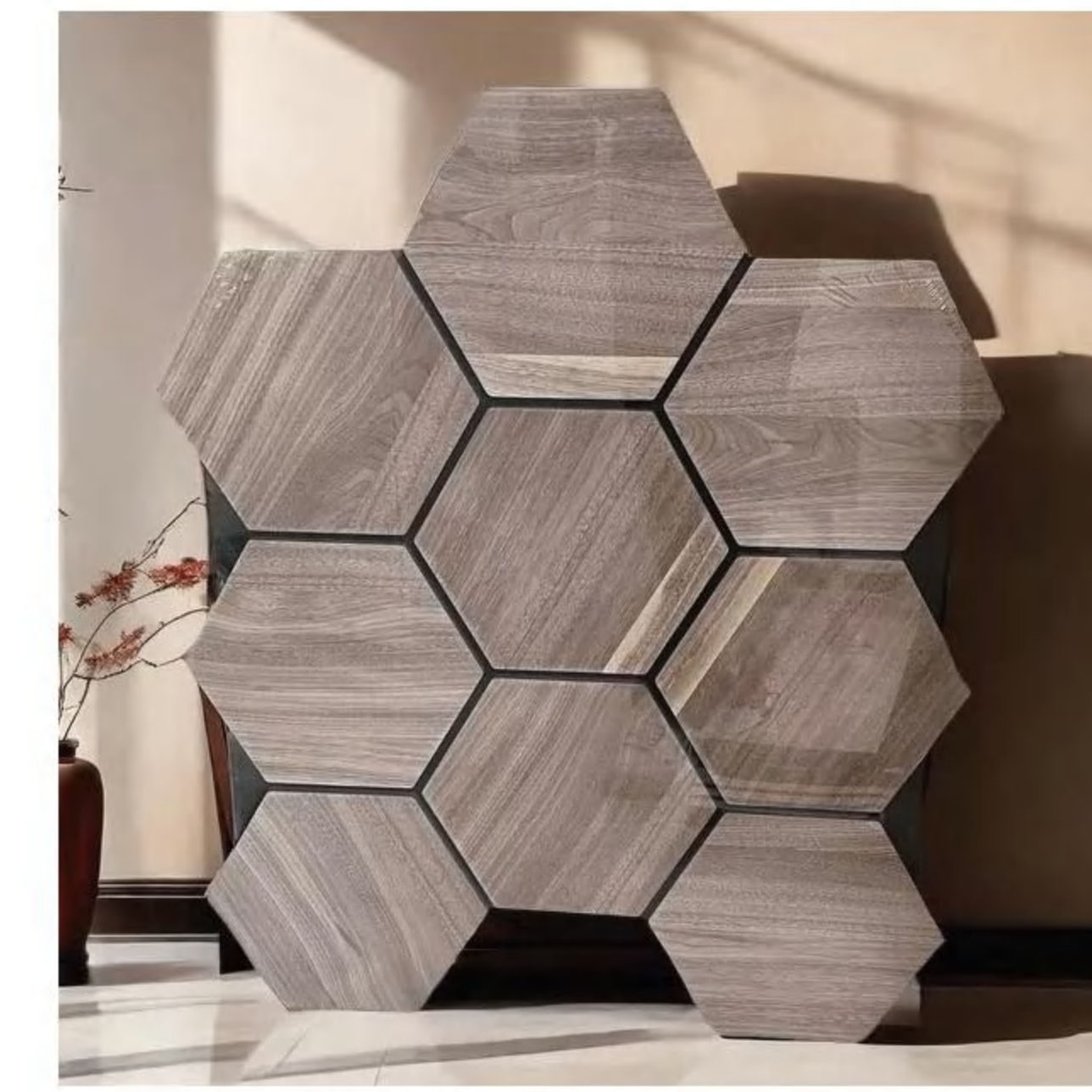



# 07 Slat Acoustic Panel

## Installation Method

### ◦ Installation

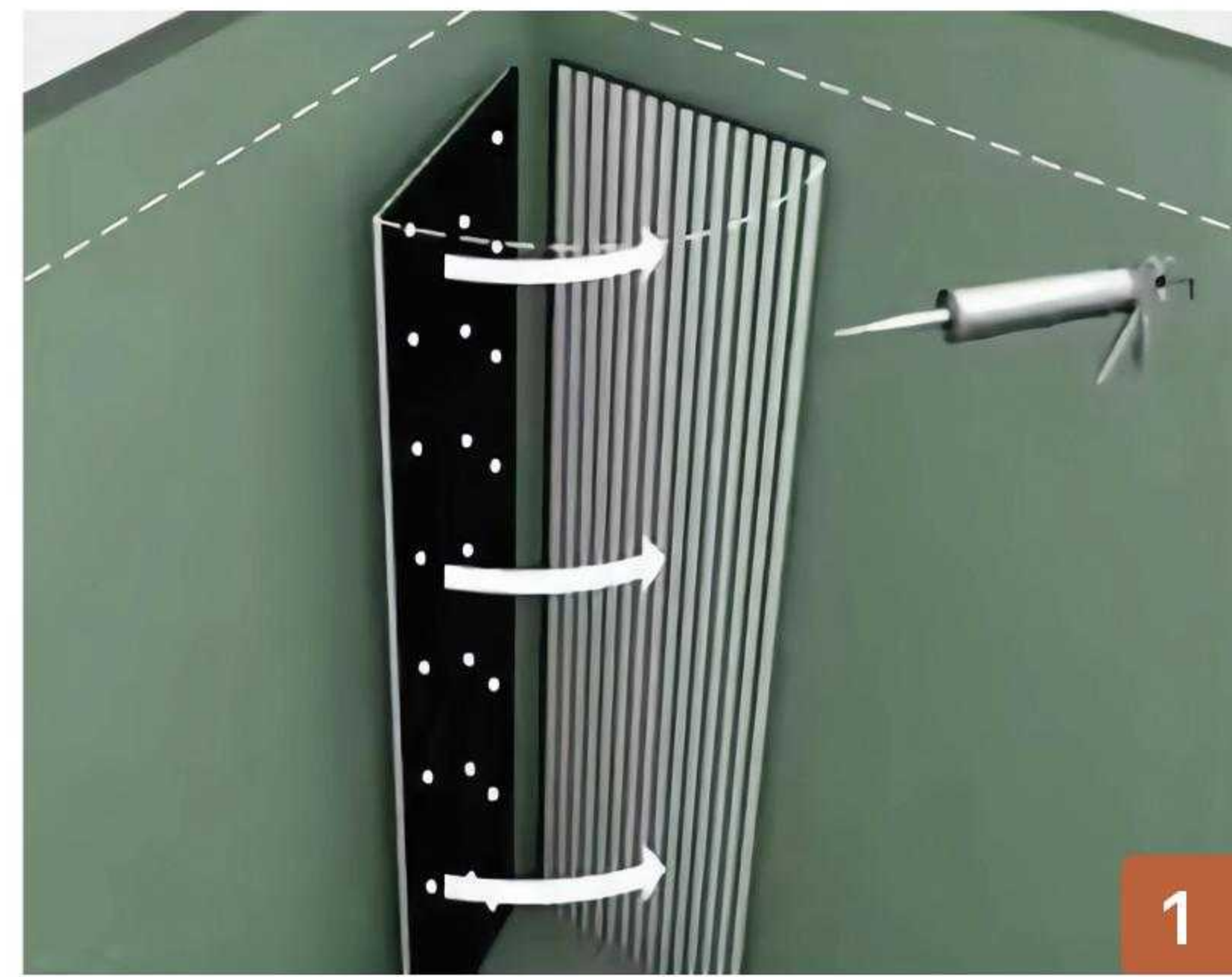

### ◦ Methods 1

#### Glue Installation

Directly use construction adhesive or structural adhesive to stick it to the wall.

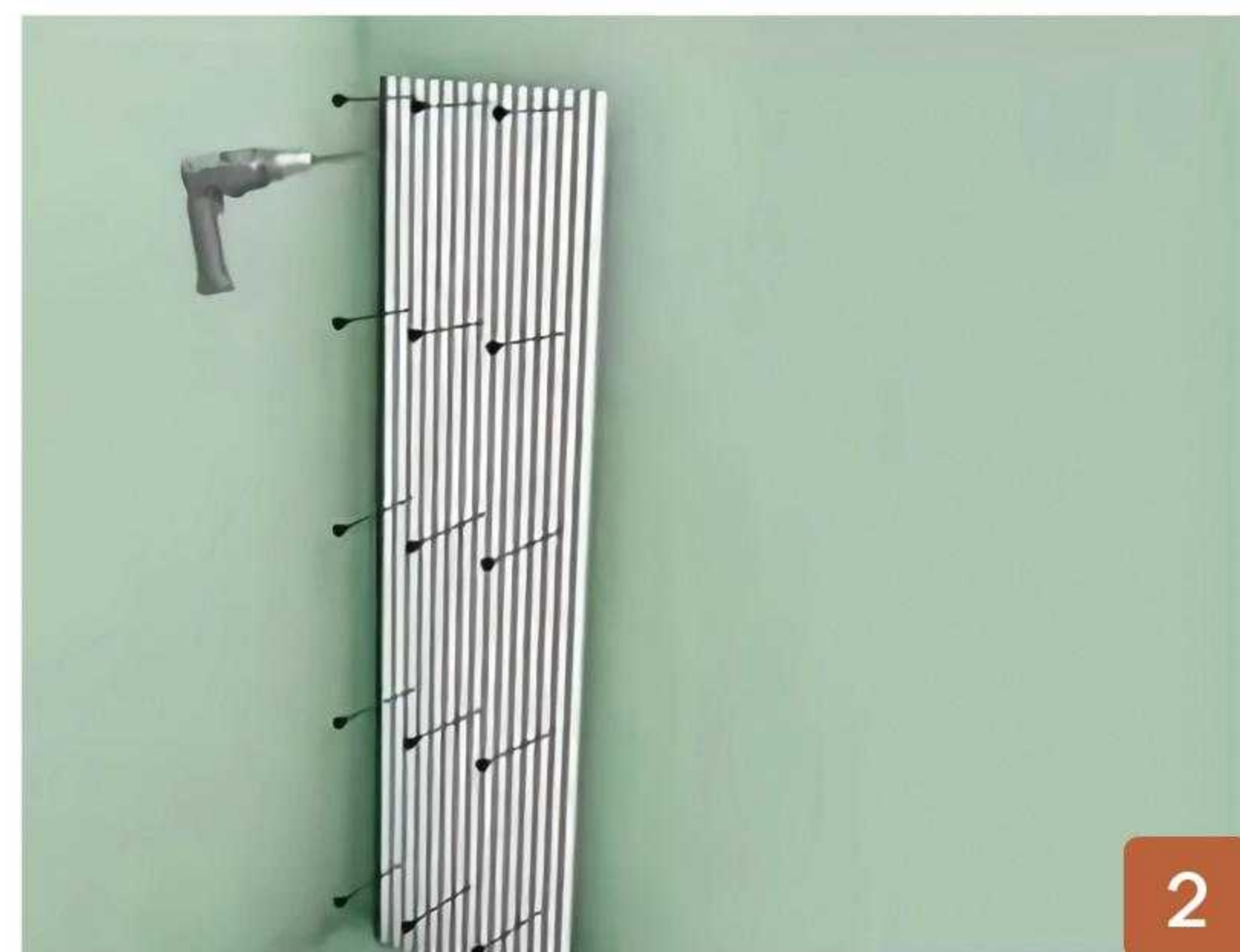

### ◦ Methods 2

#### Screw Installation

Use black screws to attach the backing board to the wall through the polyester acoustic panel. It is recommended to use at least 9 screws per grille panel.



### ◦ Methods 3

#### Wooden Battens

Directly screw the grille panel into the wooden battens. For optimal sound absorption, use polyester fiber acoustic panels and leave space behind the panels for Rockwool. This combination will achieve better sound absorption.

# 08 PU Stone Panel

## Hot-selling product series





# 08 PU Stone Panel

Hot-selling product series

Pu Stone refers to polyurethane stone, also known as artificial rock. It is an artificial stone made from materials such as polyurethane resin, fillers, and pigments through a series of processes.

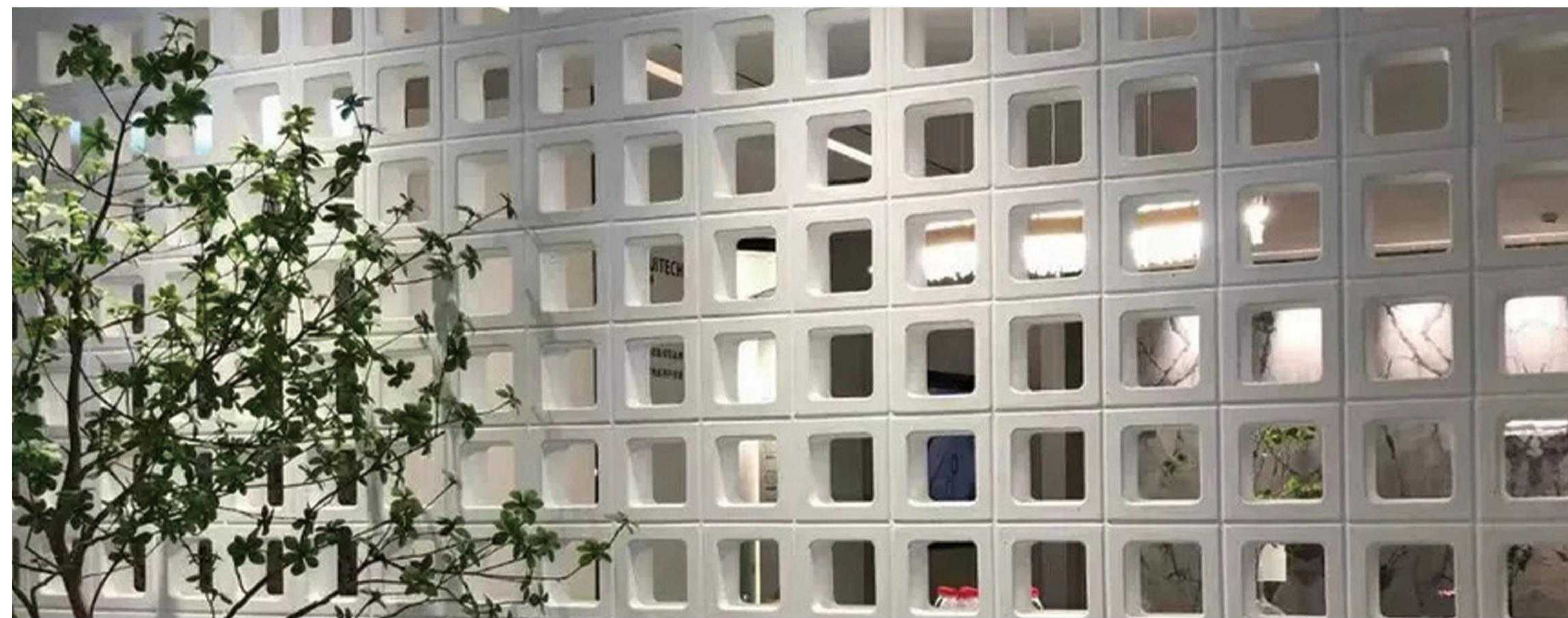

## HOLLOW BRICK

Thickness: 15-30mm  
600mm\*1200mm\*35mm

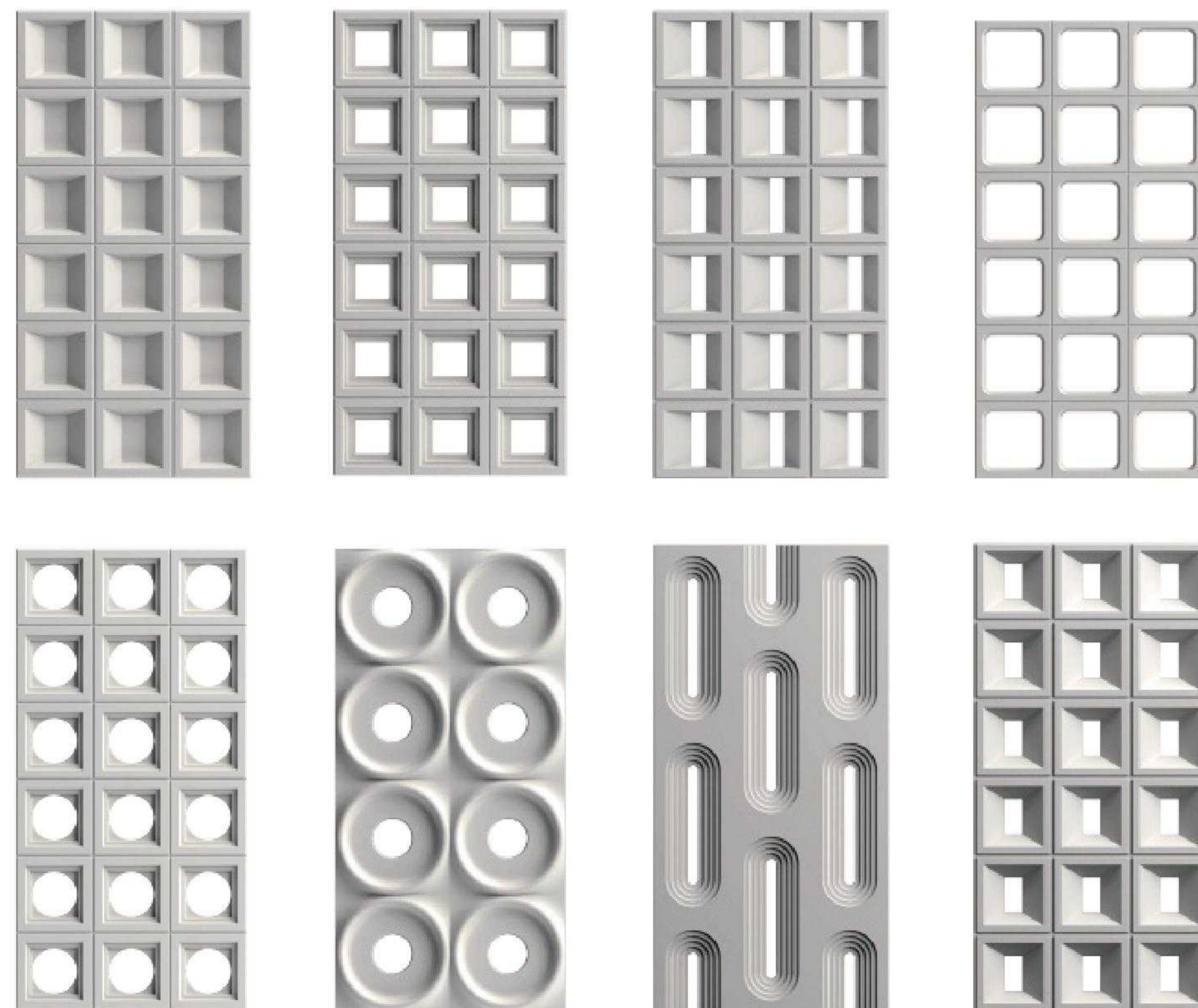

# 08 PU Stone Panel

Hot-selling product series



## PU MOUNTAIN ROCKS

Thickness: 10-80mm  
600mm\*1200mm\*70mm





**08** PU Stone Panel  
Hot-selling product series

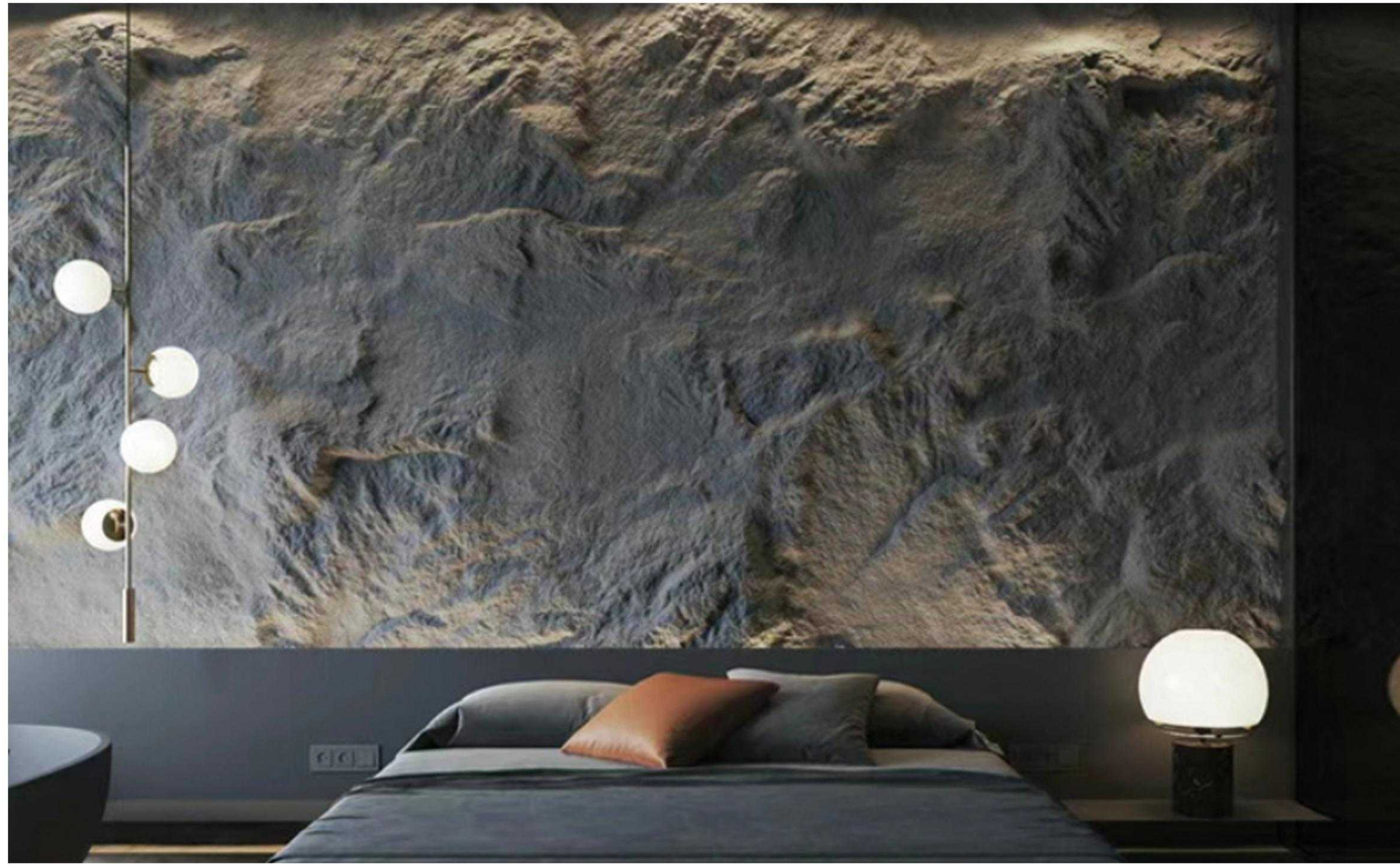

**PU BIG SLABS**

Thickness: 35mm  
600mm\*1200mm\*35mm



**08**  
Hot-selling product series

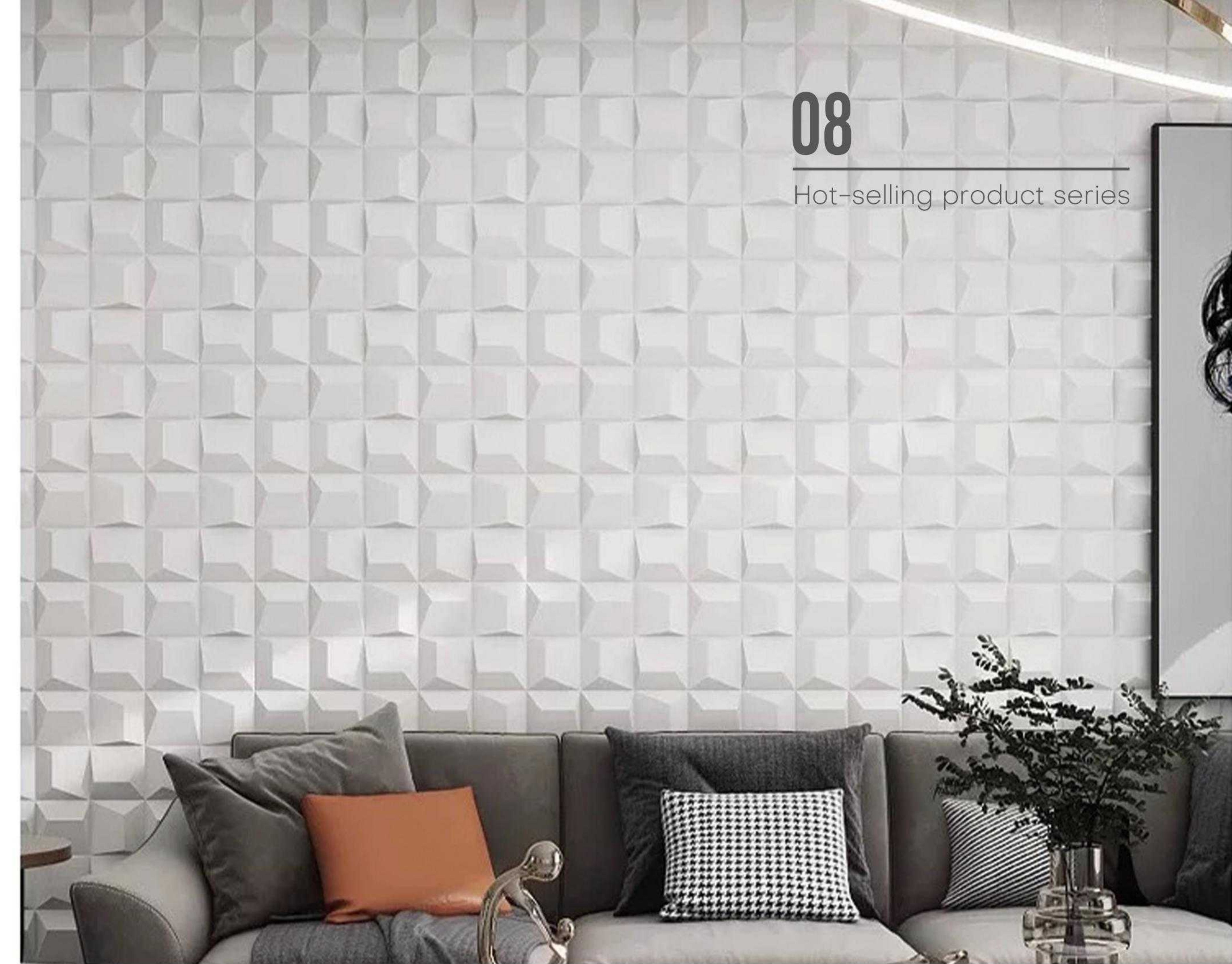

**PU GEOMETRY SERIES**

Thickness: 10-80mm  
600mm\*1200mm\*22mm



600\*1200\*22mm



600\*1200\*22mm

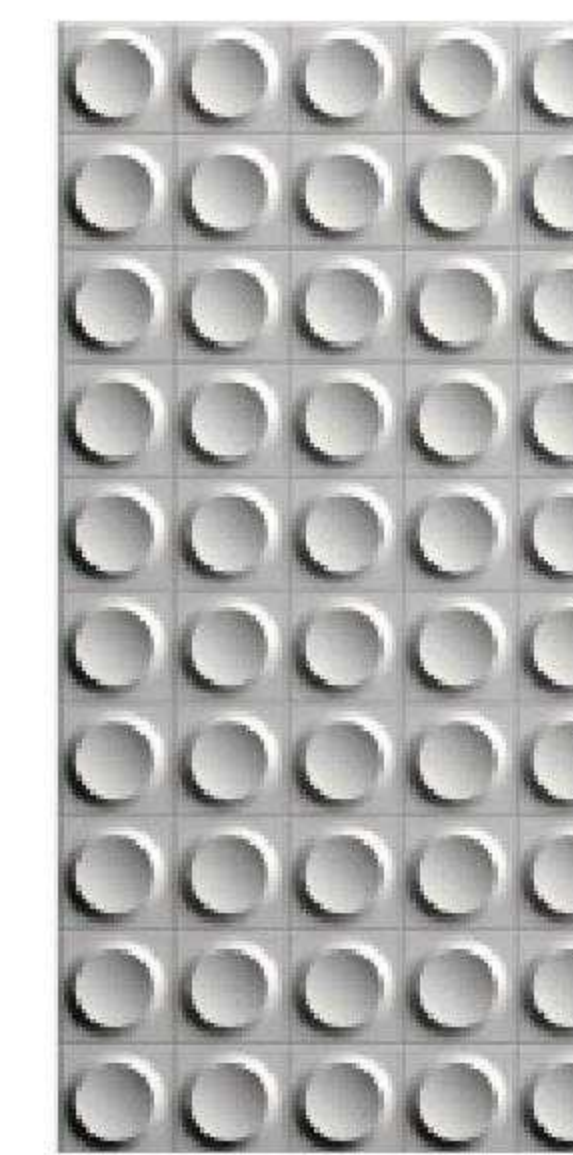

600\*1200\*22mm

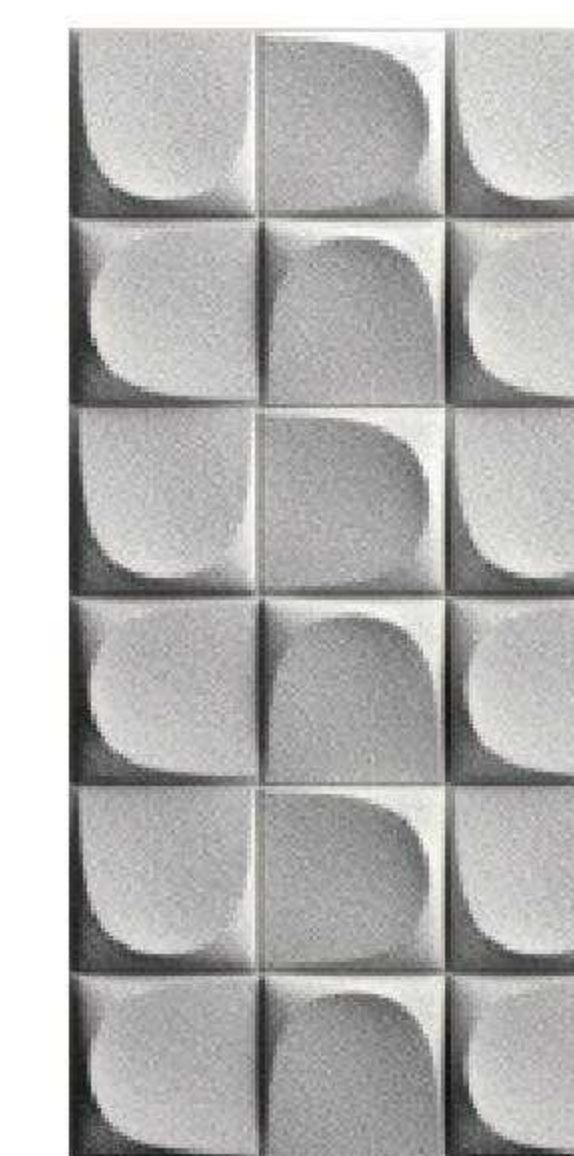

600\*1200\*35mm



600\*1200\*22mm

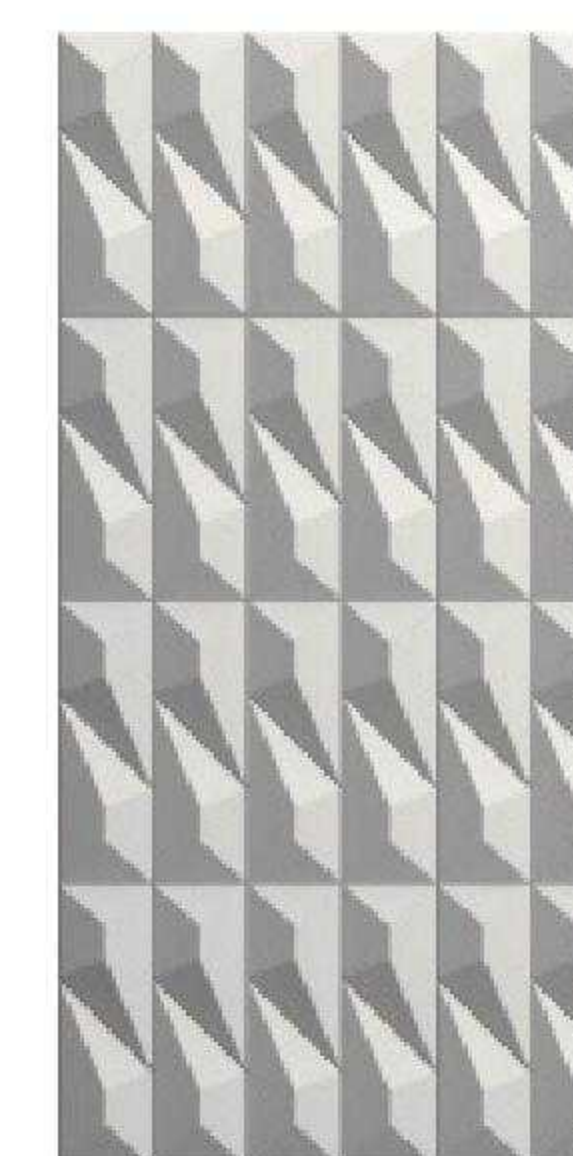

600\*1200\*22mm



**08** PU Stone Panel  
Hot-selling product series



**STACKED PEAK STONE**

Thickness: 10-80mm  
600mm\*1200mm\*50mm



**MOUNTAIN ROCK**

Thickness: 10-80mm  
600mm\*1200mm\*50mm



**08** PU Stone Panel  
Hot-selling product series



**PU STONE SKIN**

Thickness: 35mm  
600mm\*1200mm\*35mm



PU Shale Stone



PU Stone Skin



PU Mushroom Stone

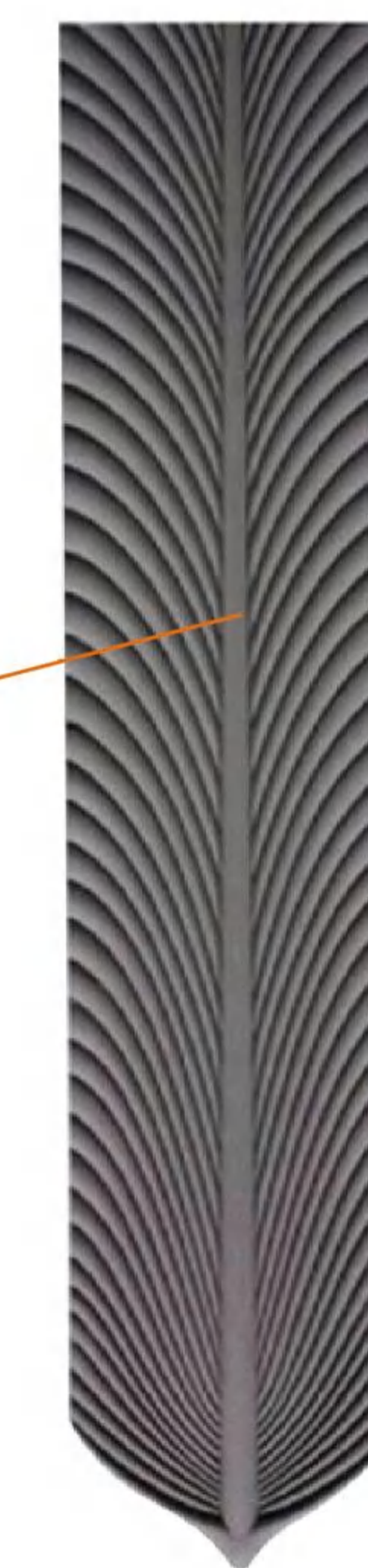
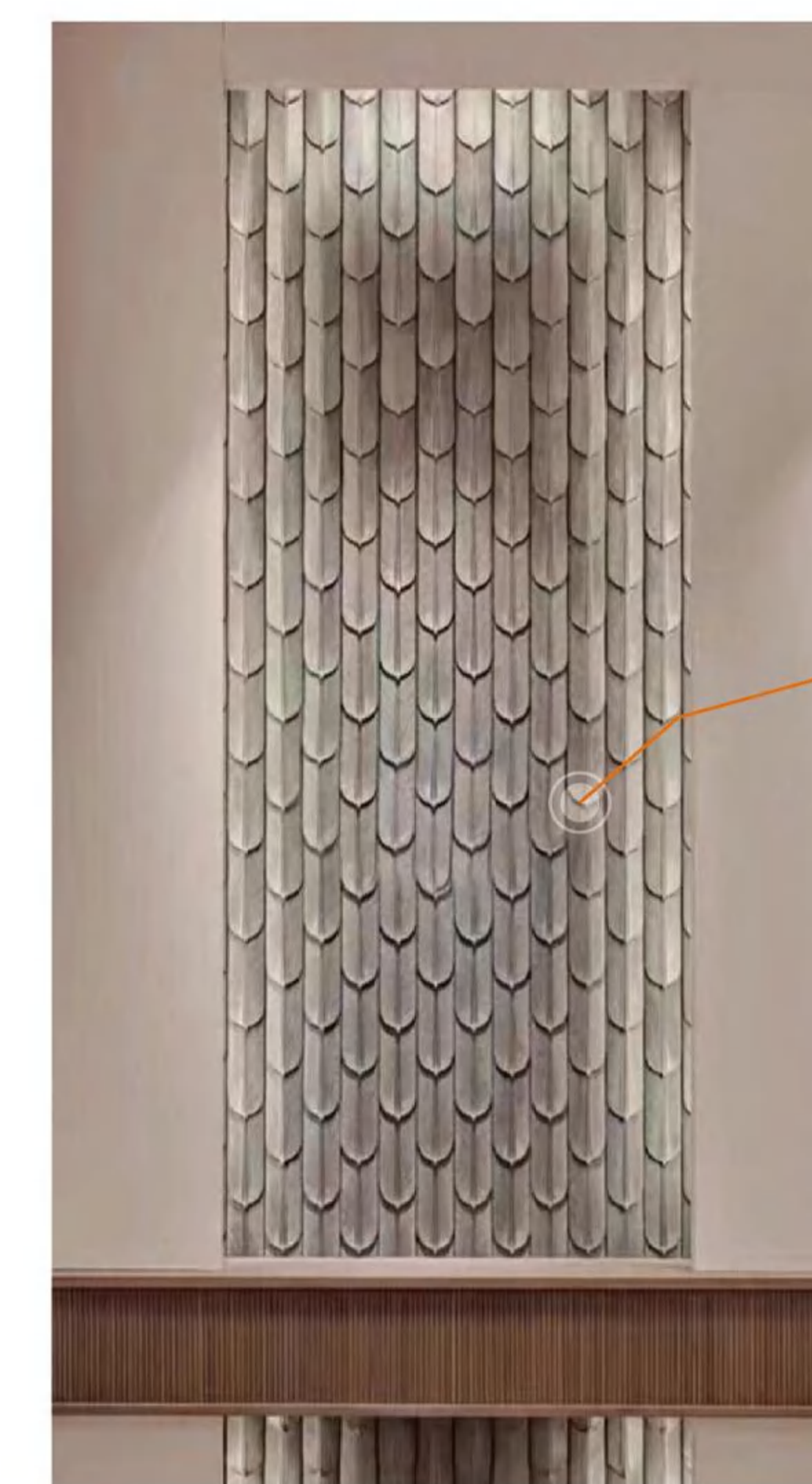

200mm

900mm

**PU FEATHER STONE**

Thickness: 20-50mm  
900mm\*200mm\*40mm



# 08 PU Stone Panel

Installation Method



## ◦ Step 1

### Cutting PU Stone Panels

Based on the measurements, use a saw to cut the PU stone panels to fit the dimensions of the installation area.



## ◦ Step 2

### Applying Adhesive

Evenly apply an appropriate amount of specialized adhesive to the back of the PU stone panels.



## ◦ Step 3

### Installing PU Stone Panels

Ensure the installation surface is clean, flat, and dry. Carefully place the PU stone panels with adhesive onto the marked positions. Press the panels firmly to ensure they adhere tightly to the installation surface.



## ◦ Step 4

### Nailing for Reinforcement

Use a nail gun to further secure the PU stone panels.

# 09 Composite Cladding

Hot-selling product series

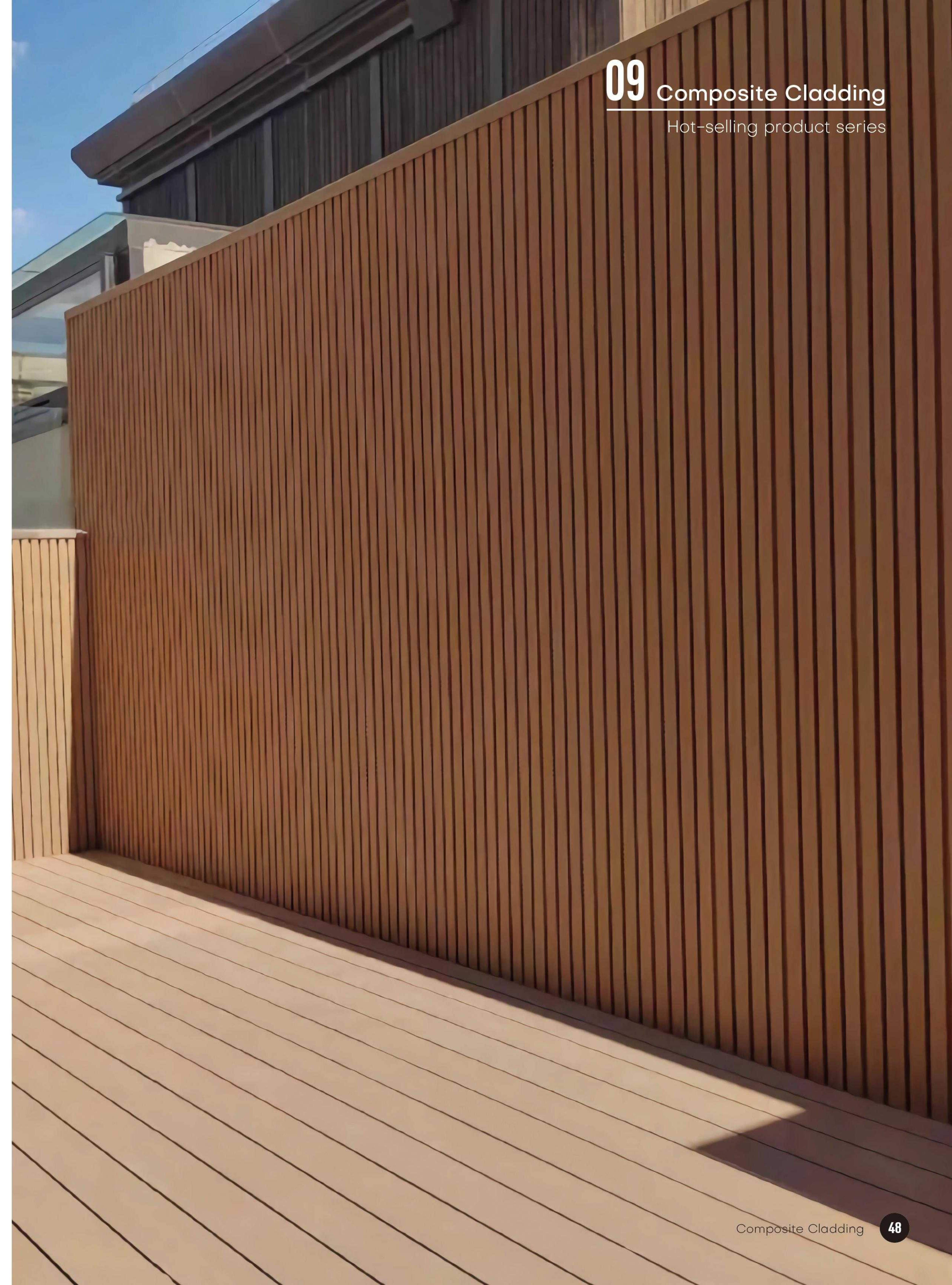





Sanding



Light Wood Grain



3d embossed

WPC Classic Wall Panel



CSP21926A

W 219mm  
H 26mm

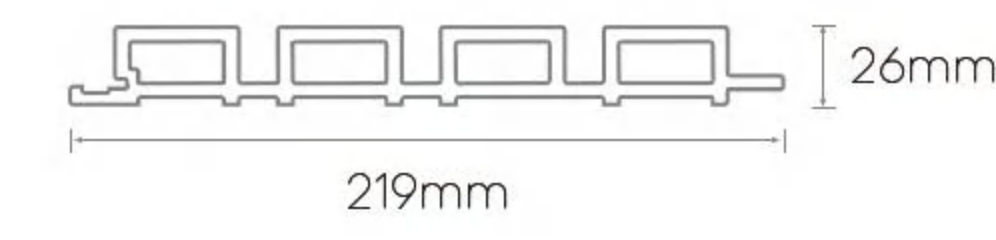

CSP14821A

W 148mm  
H 21mm

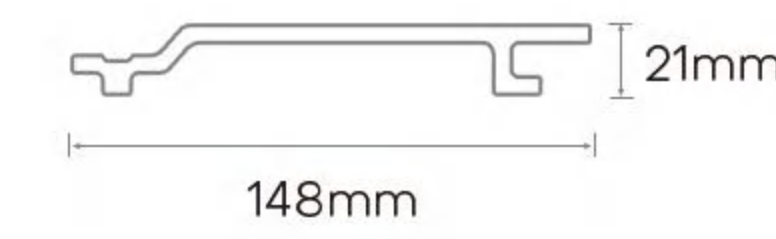

CSP15621A

W 156mm  
H 21mm

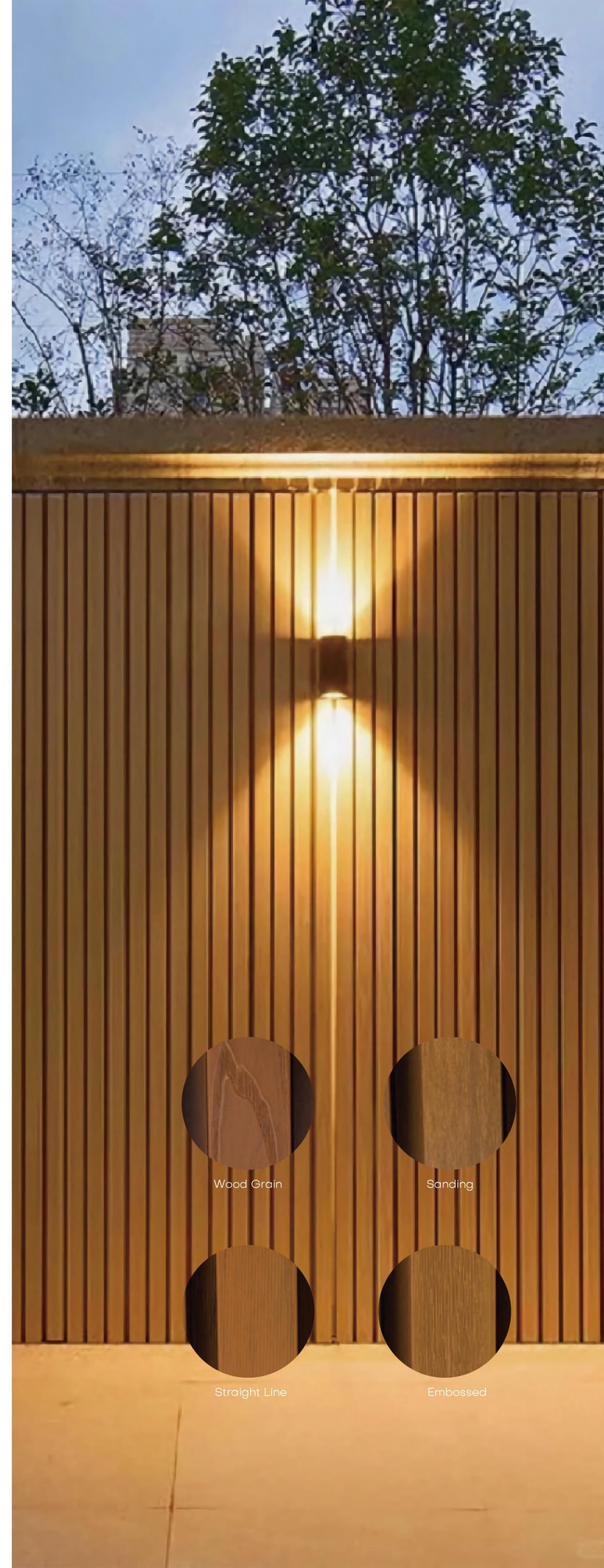
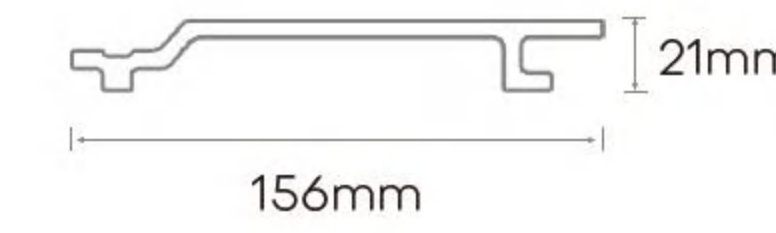

Wood Grain



Sanding



Straight Line

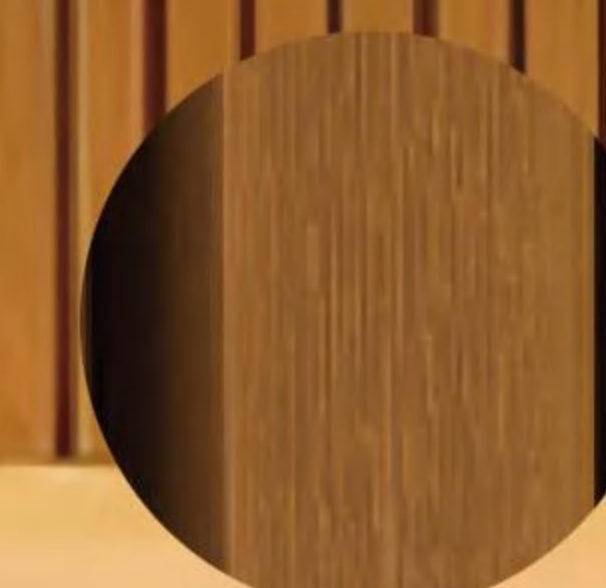

Embossed

Co-extrusion Wall Panel



CSP21926B

W 219mm  
H 26mm

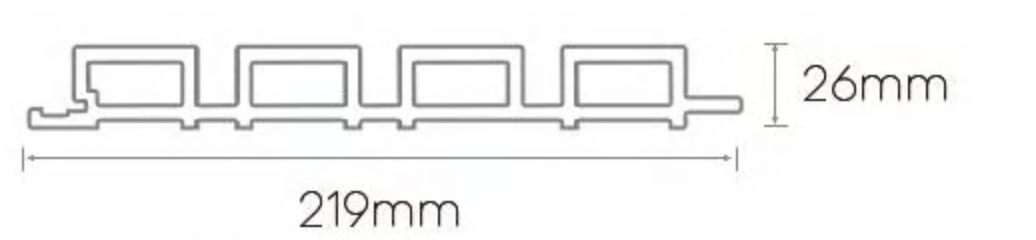

CSP21926BH

W 219mm  
H 26mm

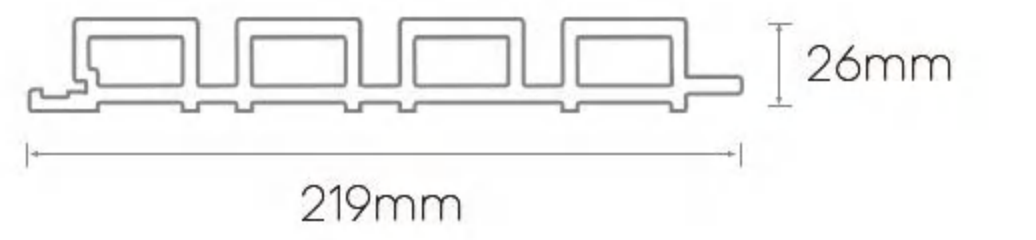

CSP15621B

W 156mm  
H 21mm

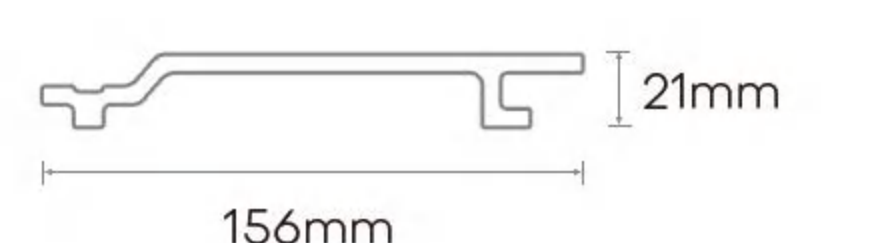



# 09 Composite Cladding

Installation Method

## Accessories



PJJX-1

PJFB-2

PJFB-3

## Installation



### Step 1

Fix the studs to the wall.



### Step 2

Secure the product to the studs.



### Step 3

Arrange the products in a front-to-back order.



### Step 4

Installation is complete.

WPC Classic Timber Tube



Co-extrusion Timber Tube



Fence Post

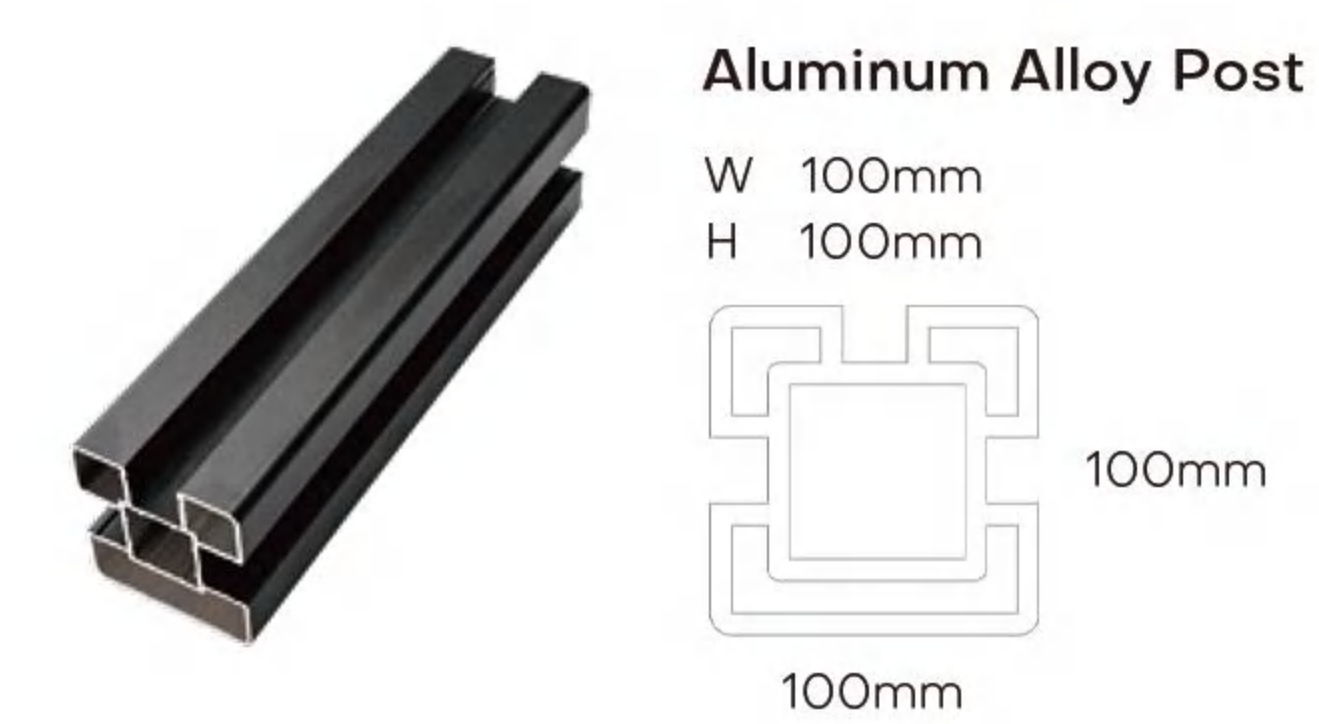

# 10 Composite Decking

Hot-selling product series





# 10 Composite Decking

Hot-selling product series

WPC decking stands for wood plastic composite decking. It is also called composite decking, or WPC flooring. Environmentally Friendly, Durable, Extremely Low-Maintenance, Scratch-Resistant, Anti-Slip, Waterproof, Fireproof, and Long-Lasting.

## WPC Classic Decking

### CSD14025AS

W 140mm  
H 25mm  
L 2900mm

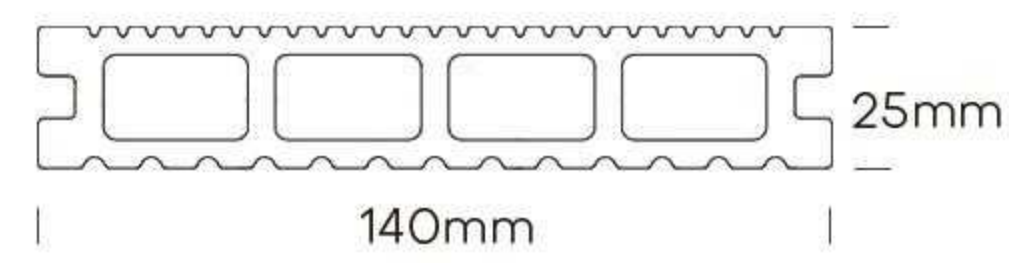

### CSD14025AR

W 140mm  
H 25mm  
L 2900mm

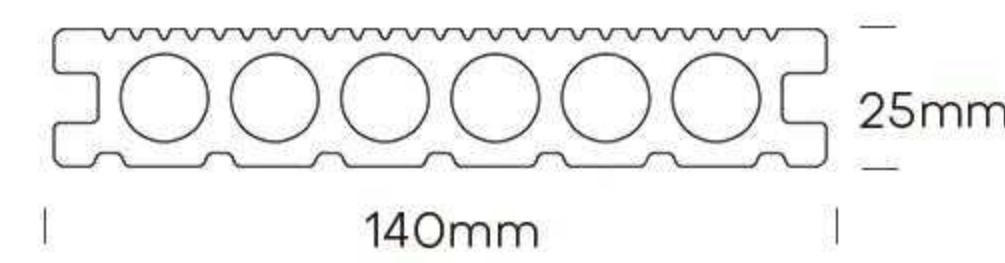

### CSD14025A

W 140mm/150mm  
H 25mm  
L 2900mm

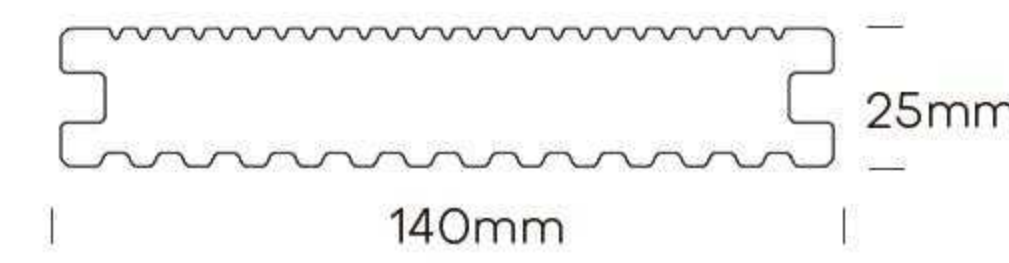
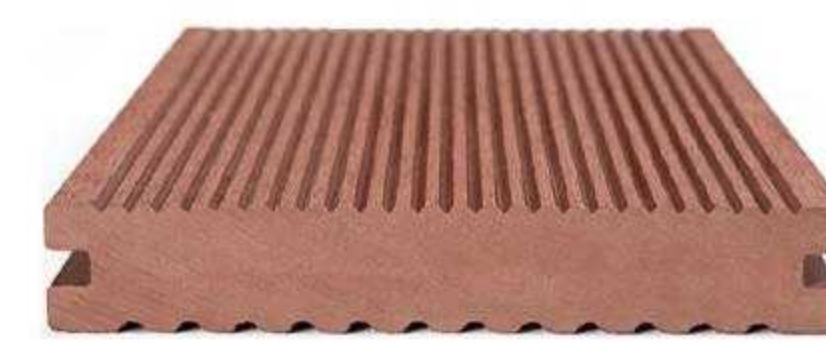

## WPC Co-extrusion Decking

### CSD13823B

W 138mm  
H 23mm  
L 2900mm

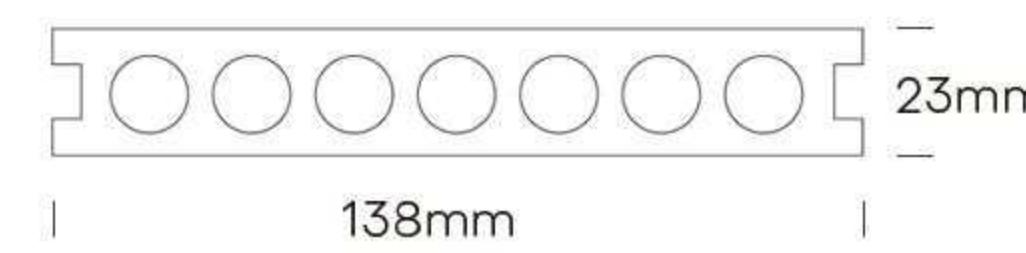

### CSD14023B

W 140mm  
H 23mm  
L 2900mm



## WPC 3D Embossed Decking

### CSD14025AS-3D

W 140mm  
H 25mm  
L 2900mm

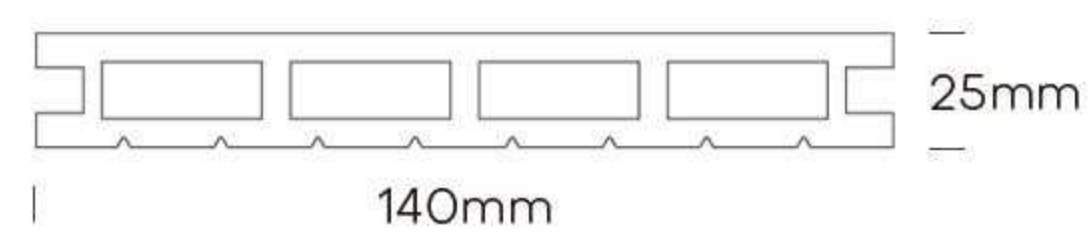

### CSD14025AR-3D

W 140mm  
H 25mm  
L 2900mm

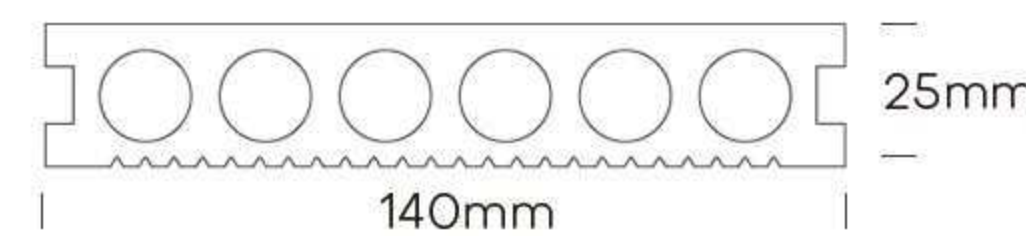

## First Generation Color Option



## WPC Co-extrusion Decking Color Option

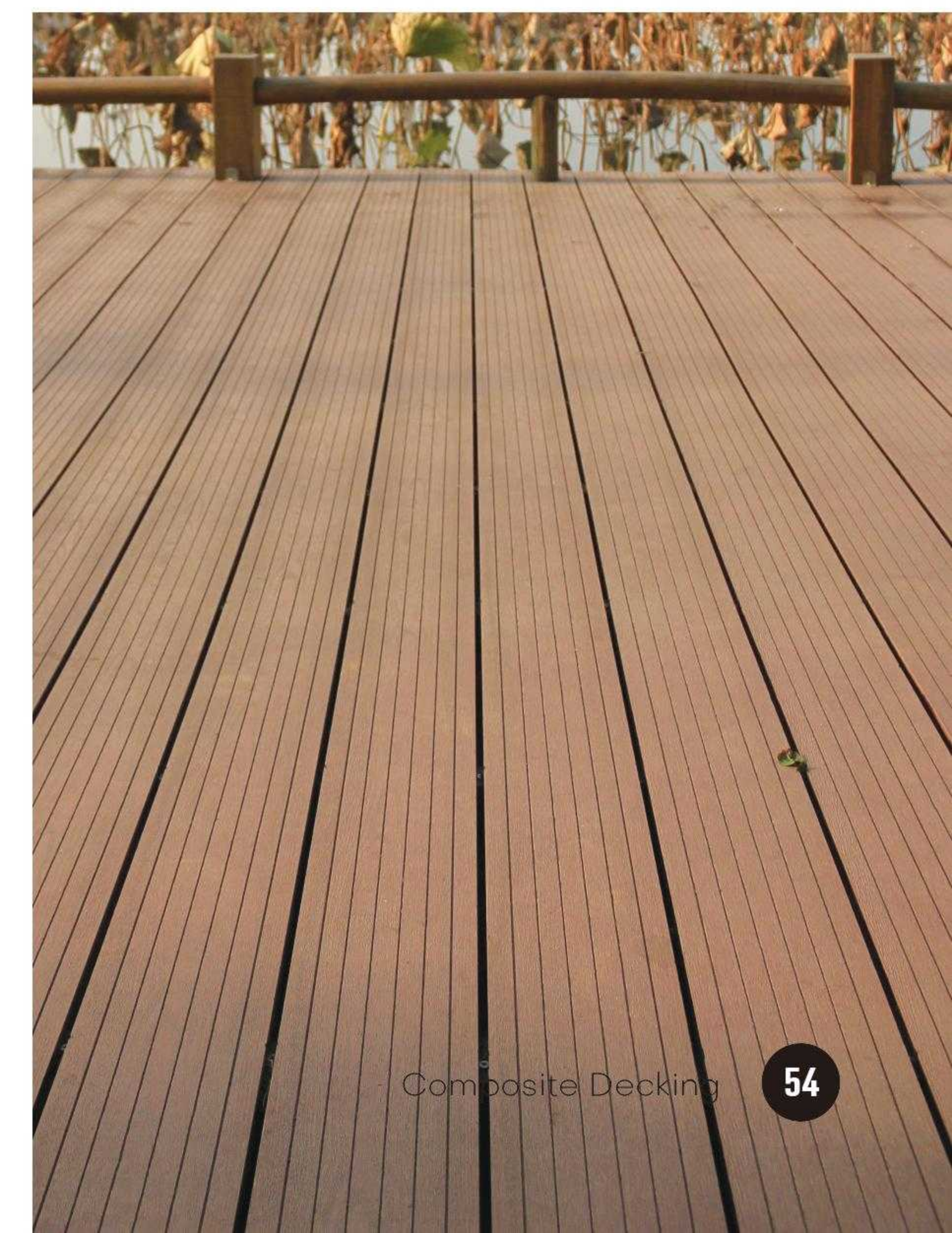
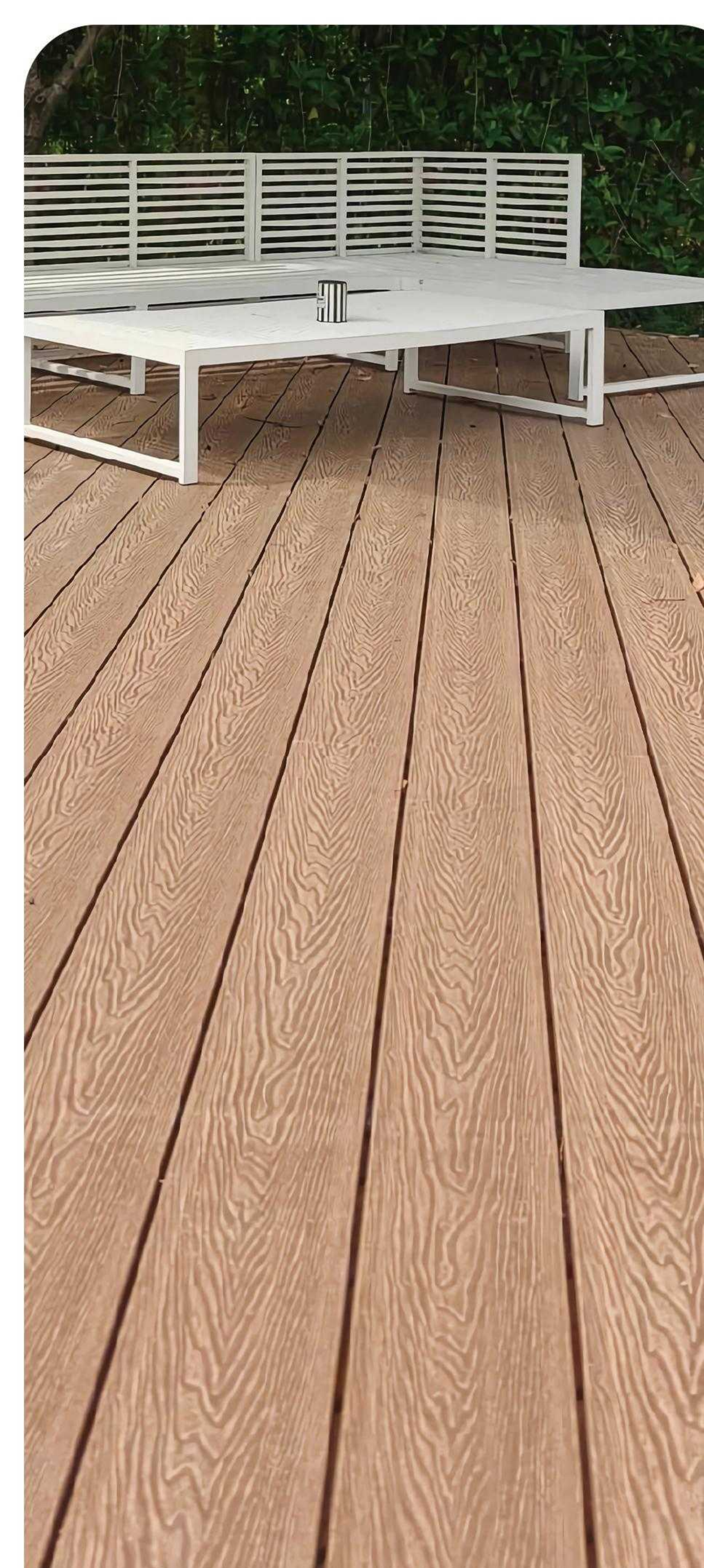



# 10 Outdoor Decking

## Installation Method

### ◦ Accessories



WPC Keel



A-1



Plastic buckle



Galvanized clip

### ◦ Installation

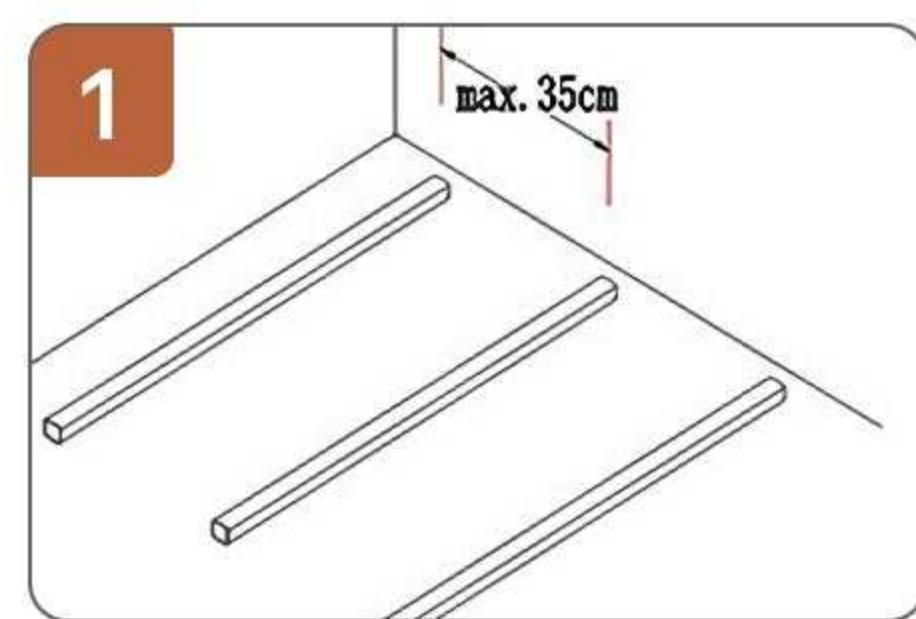

1. Install the joists, ensuring that the distance between two joists does not exceed 35 cm.

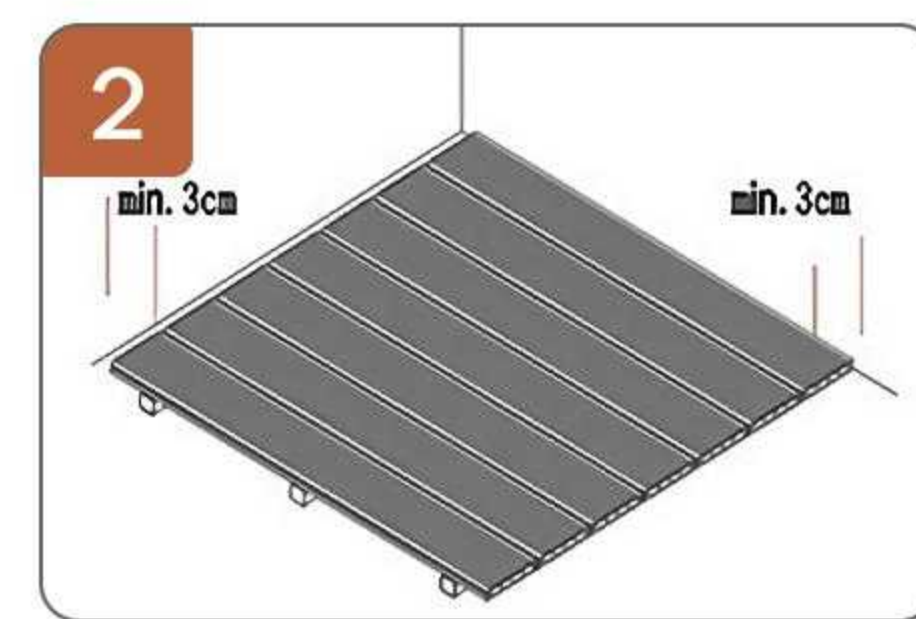

2. Leave a 3 cm gap between the decking and the building.

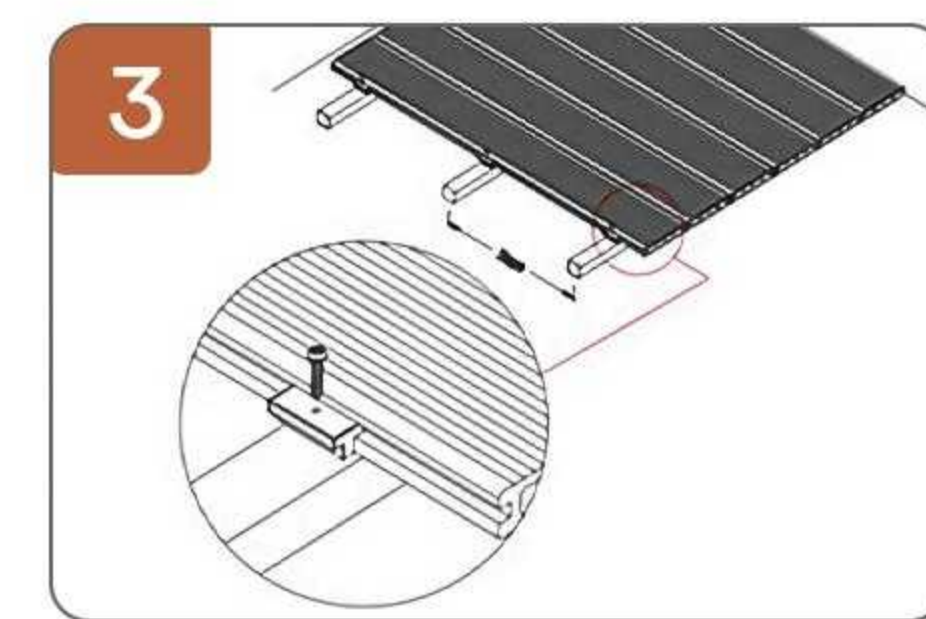

3. Secure the decking to the joists using metal fasteners.

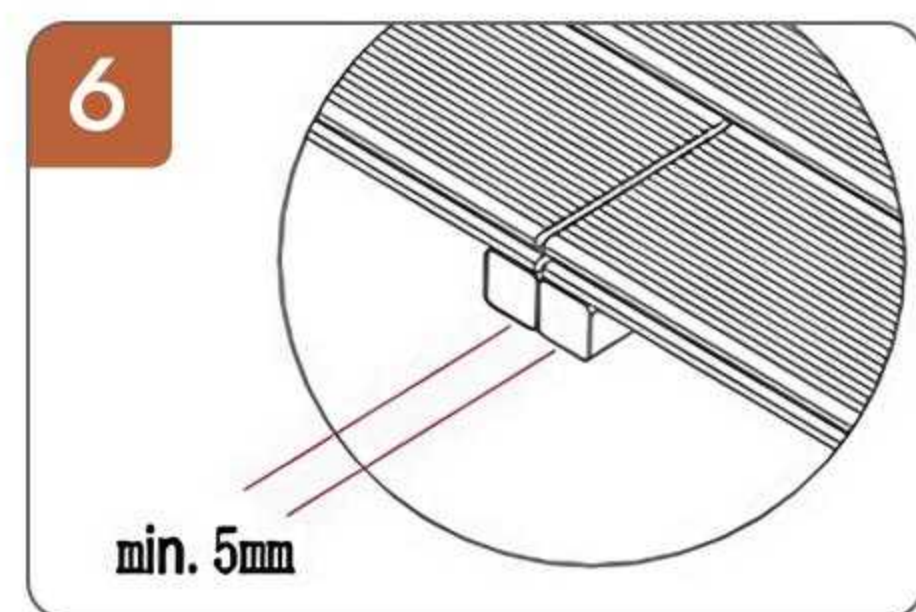

4. Ensure a gap of at least 5 mm between two decking boards.

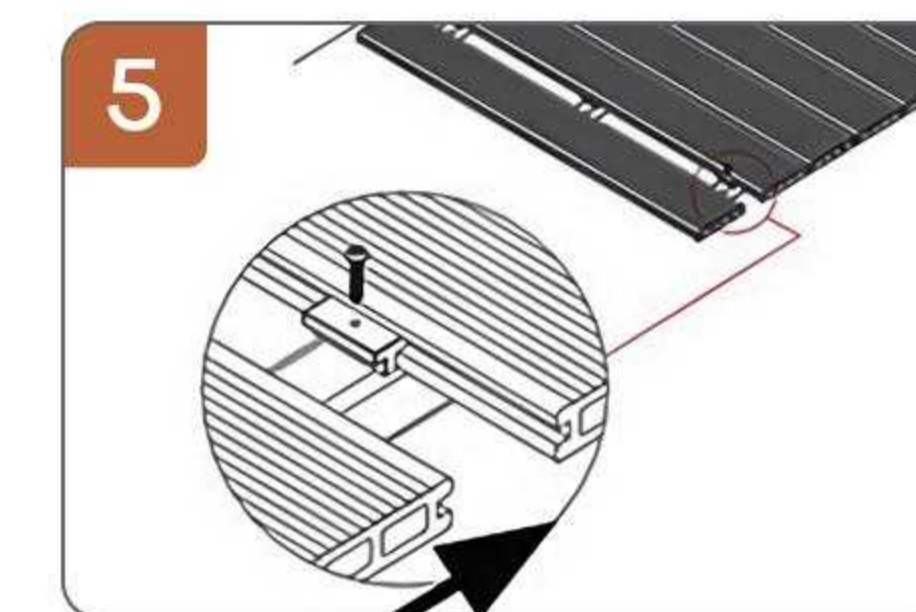

5. Connect and secure two decking boards to the joists using metal clips.

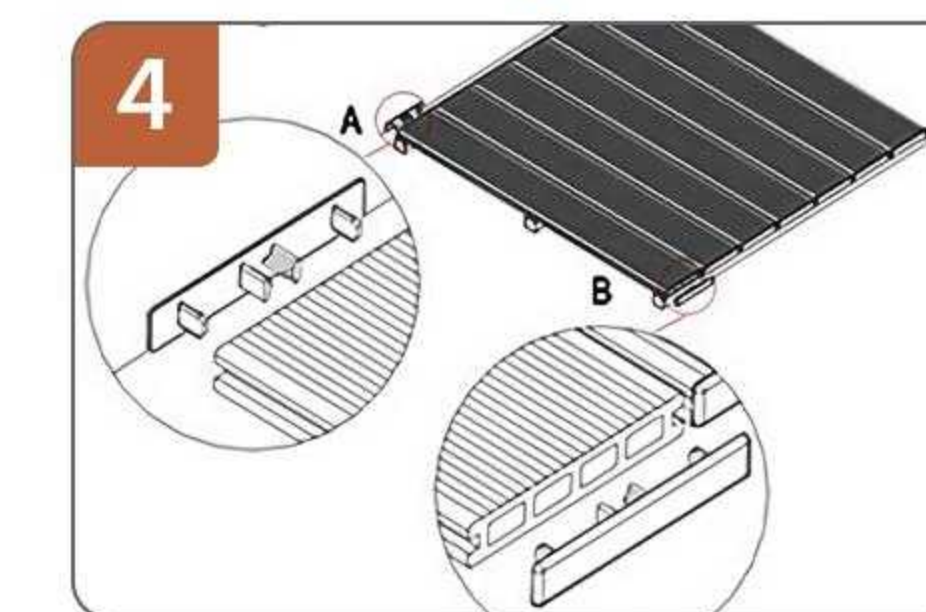

6. Seal the ends of the hollow decking boards.

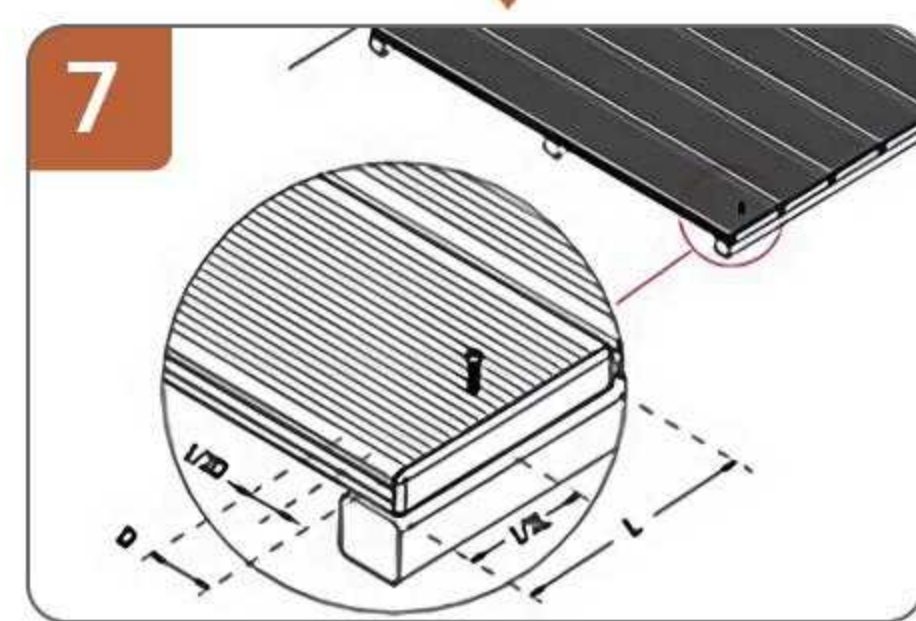

7. Fix the first and last decking boards to the surface or side using screws.

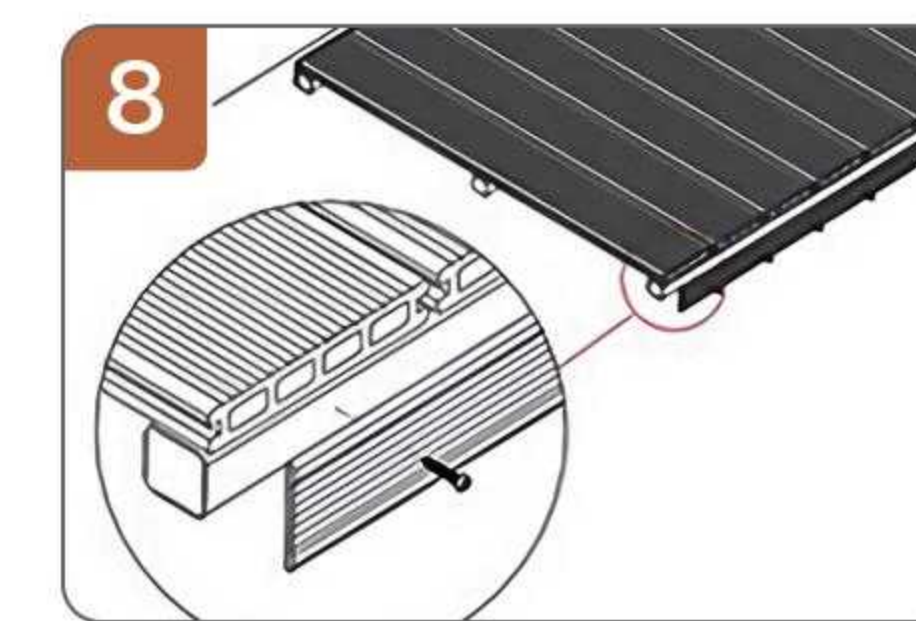

8. Install side fascia boards to finish.

THANK YOU.



● [www.aesthedge.com](http://www.aesthedge.com)